



Precision  
Agriculture



# GrowSphere™ Max

Irrigation & Fertigation Controller

**/User Manual**



Scan to  
GrowSphere™  
website

Copyright Netafim ©2026



Controller Version 2.5

# Table of Contents

## Warranty

## Safety

- Safety Overview
- Safety Conventions
- Safety Instructions

## Certifications

## Quick Start Guide

- Internal design
- Local and remote control
- System preferences
- System settings
- Wiring instructions
- Expansion modules
- Connect to remote units
- Dosing settings
- Create irrigation program

## Introduction

- GrowSphere™ MAX Overview - Architecture**
- Configurations
- Summary of GrowSphere™ MAX's main features**
- List of Connected Devices and Fertigation Functionalities
- Controller Sticker
- EC & pH connection
- Screen and Visualization
- Environmental conditions

## Installation

- Mounting GrowSphere™**
- Connecting to the CPU
- Connecting Expansion Box
- Connecting Digital Inputs
- Connecting Dosing Outputs
- Connecting Digital Outputs
- Connecting Analog Inputs
- Connecting EC/pH Units
- Connecting Energy Meter

## Controller Configuration

- Getting Started
- Dashboard Overview
- Configuring Components
- GrowSphere™ Max Alerts**

## Controller Operation

- Managing Irrigation Programs
- Irrigation Program Settings & Influence
- Viewing Logs
- System Testing
- Monitoring Irrigation

## Misting, Cooling and Humidification

- Misting, Cooling and Humidification settings
- Misting, Cooling and Humidification Program
- Misting Program
- Cooling Program
- Humidification Program
- View programs

## Dosing Other settings

- Agitator Settings
- Set agitators operation
- Setting the sub station

## Conditions & Triggers

- Conditions to start the Irrigation Program by external triggers.
- Triggers definition
- Settings of Analog sensors
- Define irrigation by conditions
- General triggers

## Mixing Valves + Pre-Ec

- Mixing valves and Pre-EC - Diagram
- Scada diagram with Pre-EC control
- Mixing Valve Selection for Pre-EC Control

## Remote Units

- Weather Station
- RadioNet to GrowSphere™ MAX**
- SingleNet to GrowSphere™ MAX**



### CAUTION:

Read the [Safety](#) instructions before installing or using the **GrowSphere™** system.



# 1. Warranty

Netafim's products are warranted to be free from defects in material and workmanship under normal use and service, for a period of twelve (12) months from the date of purchase of the products by the customer (the "Warranty Period"), provided however, that with respect to items procured by Netafim from a third party, such warranty period shall be the shorter of (i) the Warranty Period; or (ii) the warranty period granted to Netafim by the third party from which it acquired such item.

This limited warranty shall be considered as null and void and shall not apply in any of the following events:

1. Where equipment is not used or has not been installed in accordance with Netafim's specifications and installation instructions for the recommended purpose. This warranty does not extend to repair or replacement of a Netafim product or part that results from misuse, negligence, alteration, tampering, use in conjunction with parts, products or service which have not been approved by Netafim, improper or inadequate storage, installation or maintenance of the product, or any use not in accordance with the applicable user manual provided by Netafim.
2. Where chemical concentrates are used or applied internally or externally to the product not according to Netafim's instructions, and cause harm to the product or its components.
3. If operating pressures are not within the limits specified by Netafim individual components.
4. Where damage, plugging or clogging is caused by insects, rodents or other animals.
5. External causes such as accident, abuse, misuse, or problems with electrical power.
5. Normal wear and tear.
6. Any part normally consumed in operation, or which has a normal life, inherently shorter than the specified warranty period, shall not be considered defective merely due to its consumption or failure prior to the end of the warranty period.
7. Loss or damage in transit.
8. Any alterations or repairs (or attempts to make alterations or repairs) made by a party other than Netafim.
9. Any acts or omissions which exposes the products to any environment not suitable for it, with the respective specifications, including without limitation, use of toxic, corrosive, or caustic liquids and/or gases, exposure to severe weather conditions and water.
10. Any defect or problem caused by any defect in any 3rd party product used in combination with the Netafim products;
11. Any usage that is not in accordance with the provisions of section 4 to Netafim's End User License Agreement available at: \_\_\_\_\_;

12. If failures are caused by any act or event beyond the reasonable control of Netafim, natural calamities and/or force majeure, which may include, but are not limited to, war, invasion, act of foreign enemy, terrorism, hostilities (whether war be declared or not), civil war or strike, rebellion, lockouts or other industrial disputes or actions, acts of God, acts of government or other prevailing authorities or defaults of third parties, storms, temperatures, flooding, gales, snow, landslides, fire, hailstorm, lightning, earthquakes, electrical or power failures or outages or power surges or electrical spikes, or damage due to freezing or mechanical damage, failure of energy or water supply.

If a customer of Netafim identifies a defect in a Netafim product and informs Netafim of that defect during the applicable Warranty Period, Netafim will repair, replace or refund a part or the full cost of the product's purchase price, at its sole discretion, either the product or the defective part.

To receive warranty benefits, customers should return the defective product or part to the nearest Netafim™ distributor.

Netafim's warranty does not cover transit damages or spare parts required for routine maintenance. Netafim cannot and does not assume liability for defective parts, or damage caused by products not manufactured or supplied by Netafim, even though such products may be used in conjunction with Netafim™ products and the customer assumes risk of use of such third-party products.

Netafim's obligation to repair, replace or refund the cost of its products as set forth above is the sole and exclusive warranty given by Netafim. Netafim disclaims any and all other warranties, express or implied, including warranties of merchantability and fitness for a particular purpose and/ or warranty of non-infringement. Netafim will not be liable to any party in strict liability, tort, contract, or any other manner for damages caused or claimed to be caused as a result of any design or defect in Netafim's products. In addition, Netafim shall not be liable, and a customer and/or any third party shall not be entitled to recover from Netafim, any, general, special, incidental, consequential, indirect, punitive, or exemplary damages of whatsoever nature and type (including, without derogating from the generality of the foregoing, damages to crops or equipment causes by product malfunction, losses or damages caused by shutdowns or service interruptions, loss of use, non-operation of the products or any equipment, loss of information, loss of power or cost of replacement power, loss of profits or revenue, loss of contracts, loss of capital inventory or use charges, cost of purchased or replacement power, interest charges or cost of capital or claims of customer's clients or any third party) even if Netafim is aware or should have been aware of the possibility of such damages. In no event shall Netafim's liability exceed the purchase price of the Netafim products.

This warranty extends only to the customer of the Netafim product. The Netafim Warranty Period commences upon the purchase date to the customer.

Netafim reserves the right to alter, modify or redesign its products, pricing and this warranty at all times without creating any liability for the obsolescence of customer inventory or such parts or products.



## 2. Safety

### 2.1 Safety Overview

Netafim congratulates you on purchasing the **GrowSphere™ MAX** system. **GrowSphere™ MAX** system is a family of hardware, software, and cloud products designed and developed for the planning, managing, and monitoring irrigation and Nutrigation.

#### 2.1.1 Intended Audience and How to Use This Manual

This document is the user manual of the **GrowSphere™ MAX** system. It describes the essential operation and maintenance of the system.



## 2.2 Safety Conventions

The symbols used in this manual refer to the following:



### WARNING

Contains instructions aimed at preventing bodily injury or direct damage to the crops, the automation system and/or the infrastructure.



### CAUTION

Contains instructions aimed at preventing unwanted system operation, installation or conditions that, if not followed, might void the warranty.



### ATTENTION

Contains instructions aimed at enhancing the efficiency of usage of the instructions in the manual.



### NOTE

Contains instructions aimed at emphasizing certain aspect of the operation of the system or installation.



### ACID HAZARD

Contains instructions aimed at preventing bodily injury or direct damage to the crops and/or the irrigation system in the presence of acid.



### ELECTRICAL HAZARD

Contains instructions aimed at preventing bodily injury or direct damage to the irrigation system components in the presence of electricity.



### SAFETY FOOTWEAR

Contains instructions aimed at preventing foot injury.



### WARNING



Contains instructions aimed at preventing damage to health or bodily injury in the presence of nutrients, acid or chemicals.



## 2.3 Safety Instructions

- All safety regulations must be applied
- Use only approved accessories specified by Netafim™ for the **GrowSphere™** equipment. Failure to do so may result in the system operating in a dangerously unsafe condition
- Unauthorized modification of the product will negate the approval rating of the product and the warranty
- Protection provided by the equipment can be impaired if the equipment is used in a manner other than that specified by the manufacturer



### WARNING

In an agricultural environment - always wear protective footwear.

### 2.3.1 Electrical Safety Precautions

Electrical installation, maintenance and troubleshooting procedures must be performed by an authorized electrician only.

### 2.3.2 Overhead Power Lines



### WARNING

When installing **GrowSphere™** units, care must be taken:

- Insure there is always clear space from overhead power lines.
- Do not erect any pole and associated **GrowSphere™** unit if power lines are in the vicinity.
- Check with your relevant authority as to the clearances from power lines required in your region.



## 2.3.3 Batteries

- Use only Netafim™ approved batteries on the **GrowSphere™** equipment
- Do not puncture the battery
- Avoid contact with the corrosive material in the battery
- Exercise care in handling any charged battery, particularly when placing it inside a container (toolbox) amidst metal objects
- Always responsibly dispose of a used battery - in the intended places for battery recycling
- It is important not to dispose of large numbers of alkaline batteries in a group

## 2.3.4 RF remote units

- The **GrowSphere™** system meets the local RF regulations of every country and state
- The system is supplied with the proper documentation to be submitted to the Local authorities, such as the Ministry of Communication, Customs, or any other governmental agency

According to the manufacture data sheet, The GS Max maximal temperature for the following components are:

- CPU: 60 degrees Celsius
- Teltonika modem: 75 degrees Celsius
- Screen: 60 degrees Celsius



## 2.3.5 Thunderstorms

If the area is known to be prone to thunderstorms, **GrowSphere™** installed in the fields, may attract lightning discharge, as they are the highest object in the vicinity.

In such case it is recommended to install a lightning rod in the **GrowSphere™** vicinity.

A lightning rod is a metal rod installed on a pole and grounded.

The lightning rod should be the highest object in the vicinity in order to properly attract the lightning discharge and direct it safely into the ground.

## 2.3.6 Working at height

**To prevent fatalities or major injuries, all safety measures regarding work at height must be observed.**

**Without limiting the foregoing:**

- Avoid work at height whenever possible
- As much work as possible should be done from the ground (whenever possible: mount the unit on the pole, wire it and then erect the fully equipped pole into position)



### **WARNING**

Mounting the base unit and routers and erecting poles might require working at height.

### **If work at height cannot be avoided:**

- All work at height must be properly planned, supervised and carried out by competent, trained and experienced personnel, authorized by the local safety authority
- Make sure equipment used for work at height is certified by the local standards authority, well maintained and inspected regularly
- Avoid standing on fragile surfaces such as shingle or asbestos cement roofs
- For the entire duration of work at height a person should be present on the ground, constantly keeping eye-contact with the workers at height, ready to assist them when needed
- When working at height make sure that nobody is standing under you
- Make sure the surface, scaffold or ladder used are stable and strong enough to support the worker's weight and that of the equipment
- Always wear a harness and make sure it is correctly anchored to a stable element
- Always use tools designed for work at height and make sure that they are secured in a basket preventing them from falling



# 3. Certifications



## EU DECLARATION OF CONFORMITY

We Netafim Ltd, declare under our sole responsibility:

**Type of equipment:** Irrigation and fertigation controller  
**Brand name or trade mark:** GrowSphere  
**Product Identification number:** GS-MAX-DD-220V-6DO-12DI  
**Country of origin:** Israel  
**Manufacturer:** Netafim Ltd  
**The authorized representative located within the Community is:** ...Elad Levi.....  
**Address:** Aartsdijkweg 22, 2676 LE Maasdijk, Netherlands.

**Essential requirements according to directives:**

1. 2014/53 RED
2. 2014/30/EU EMCD
3. 2014/35/EU LVD
4. 2011/65/EU RoHS

**Standards applied:**

1. ETSI EN 300 328 V2.2.2 (2019-07), ETSI EN 300 328 V2.2.2 (2019-07), EN 62311:2008, ETSI EN 301 489-1 V2.2.3 (2019-11), ETSI EN 301 489-17 V3.2.4 (2020-09), ETSI EN 301 489-52 V1.2.1 (2021-11).
2. EN 55032:2015+A11:2020, EN 55035:2017+A11:2020, EN IEC 61000-3-2:2019+A1:2021, EN 61000-3-3:2013+A2:2021
3. IEC 61010-1:2010, AMD1:2016

**Test reports/ certificates issued by:** Global United Technology Services Co., Ltd., report numbers:

1. GTS2023110170E01, GTS2023110170E02, GTS2023110170E03, GTS2023110170E04
2. GTS2023110170E05
3. GTS2023110170S02

As the manufacturer or manufacturer's authorized representative within the EEA, we declare under our sole responsibility that the equipment follows the provisions of the Directive(s) as stated above.

Thus  is placed on the product

Date of issue: ..... Feb.10<sup>th</sup> 2025.....

Place of issue: ..... Netherlands.....

(Signature & Name of authorized person) *Elad Levi*

(Company Stamp)



## EU DECLARATION OF CONFORMITY

We Netafim Ltd, declare under our sole responsibility:

**Type of equipment:** Irrigation and fertigation controller  
**Brand name or trade mark:** GrowSphere  
**Product Identification number:** GS-MAX-DD-220V-6DO-12DI  
**Country of origin:** Israel  
**Manufacturer:** Netafim Ltd  
**The authorized representative located within the Community is:** ...Elad Levi.....  
**Address:** Aartsdijkweg 22, 2676 LE Maasdijk, Netherlands.

**Essential requirements according to directives:**

1. 2014/53 RED
2. 2014/30/EU EMCD
3. 2014/35/EU LVD
4. 2011/65/EU RoHS

**Standards applied:**

1. ETSI EN 300 328 V2.2.2 (2019-07), ETSI EN 300 328 V2.2.2 (2019-07), EN 62311:2008, ETSI EN 301 489-1 V2.2.3 (2019-11), ETSI EN 301 489-17 V3.2.4 (2020-09), ETSI EN 301 489-52 V1.2.1 (2021-11).
2. EN 55032:2015+A11:2020, EN 55035:2017+A11:2020, EN IEC 61000-3-2:2019+A1:2021, EN 61000-3-3:2013+A2:2021
3. IEC 61010-1:2010, AMD1:2016

**Test reports/ certificates issued by:** Global United Technology Services Co., Ltd., report numbers:

1. GTS2023110084E01, GTS2023110084E02, GTS2023110170E03, GTS2023110170E04
2. GTS2023110084E03
3. GTS2023110084S01

As the manufacturer or manufacturer's authorized representative within the EEA, we declare under our sole responsibility that the equipment follows the provisions of the Directive(s) as stated above.

Thus  is placed on the product

Date of issue: ..... Feb.10<sup>th</sup> 2025.....

Place of issue: ..... Netherlands.....

(Signature & Name of authorized person) *Elad Levi*

(Company Stamp)





**EU DECLARATION OF CONFORMITY**

We Netafim Ltd, declare under our sole responsibility:

**Type of equipment:** Irrigation and fertigation controller  
**Brand name or trade mark:** GrowSphere  
**Product Identification number:** GS-MAX-NO\_DISP-220V-6DO-12DI  
**Country of origin:** Israel  
**Manufacturer:** Netafim Ltd  
**The authorized representative located within the Community is:** ...Elad Levi....  
**Address:** Aartsdijkweg 22, 2676 LE Maasdijk, Netherlands.

**Essential requirements according to directives:**

1. 2014/53 RED
2. 2014/30/EU EMCD
3. 2014/35/EU LVD
4. 2011/65/EU RoHS

**Standards applied:**

1. ETSI EN 300 328 V2.2.2 (2019-07), ETSI EN 300 328 V2.2.2 (2019-07), EN 62311:2008, ETSI EN 301 489-1 V2.2.3 (2019-11), ETSI EN 301 489-17 V3.2.4 (2020-09), ETSI EN 301 489-52 V1.2.1 (2021-11).
2. EN 55032:2015+A11:2020, EN 55035:2017+A11:2020, EN IEC 61000-3-2:2019+A1:2021, EN 61000-3-3:2013+A2:2021
3. IEC 61010-1:2010, AMD1:2016

**Test reports/ certificates issued by:** Global United Technology Services Co., Ltd., report numbers:

1. GTS2023110190E02, GTS2023110170E02, GTS2023110190E02, GTS2023110170E04
2. GTS2023110190E05
3. GTS2023110190S02

As the manufacturer or manufacturer's authorized representative within the EEA, we declare under our sole responsibility that the equipment follows the provisions of the Directive(s) as stated above.

Thus  is placed on the product

Date of issue: ..... Feb. 10<sup>th</sup> 2025.....

Place of issue: ..... Netherlands.....

(Signature & Name of authorized person)

*Elad Levi*

(Company Stamp)

DocuSign Envelope ID: 8B78A166-90B1-40C4-8010-BB0C1A09CA89



**FCC SUPPLIER'S DECLARATION OF CONFORMITY**

We Netafim Ltd, declare:

**Types of equipment:** Irrigation and fertigation controller  
**Brand name or trademark:** GrowSphere  
**Product name:** ECO  
**Country of origin:** Israel  
**Manufacturer:** Netafim Ltd  
**Responsible Party name (IN USA):** Mike Hemman  

- Address: 4570 E. Home Ave., Fresno, CA 93727
- Telephone: (559) 250-3632
- E-Mail: Mike.hemman@netafim.orbia.com

**Identification of the assembled product:**

- ECO

**Identification of the authorized modular components used in the assembly:**

- Modular 1, FCC ID: XMR201906EG21G
- Modular 2: FCC ID: 2AC7Z-ESPC3WROOM3

**Copies of Compliance Statements for each SDoC modular component used:**

- Modular 1, FCC ID: XMR201906EG21G
- Modular 1, FCC ID: 2AC7Z-ESPC3WROOM3

**Standards applied:**

- FCC Part 15B - For Unintentional radiators (test report number: GTS2024050323F01)

**Test reports/ certificates issued by:** Global United Technology Services Co., Ltd.

**Applicable Compliance Statements:**

(§15.19(a)(3): This device complies with related rules, operation is subject to the following two conditions: (1). This device may not cause harmful interference and, (2). This device must accept any interference received, including interference that may cause undesired operation.

As the manufacturer's authorized representative within the USA, we declare under our sole responsibility that the equipment follows the provisions of FCC Equipment Authorization Procedure 47 CFR §2.906 - SUPPLIER'S DECLARATION OF CONFORMITY as stated above.

The following responsible party designated in FCC 47 CFR §2.909 is responsible for this declaration.

Thus  is placed on the product

Date of issue: Mar 5, 2025

Place of issue: Fresno, California

*Mike Hemman*

Mike Hemman,  
President Netafim North America



DocuSign Envelope ID: 8B78A166-90B1-40C4-8010-BB0C1A09CA89



## FCC SUPPLIER'S DECLARATION OF CONFORMITY

We Netafim Ltd, declare:

**Types of equipment:** Irrigation and fertigation controller

**Brand name or trademark:** GrowSphere

**Product name:** FLEX

**Country of origin:** Israel

**Manufacturer:** Netafim Ltd

**Responsible Party name (IN USA):** Mike Hemman

- Address: 4570 E. Home Ave., Fresno, CA 93727
- Telephone: (559) 250-3632
- E-Mail: Mike.hemman@netafim.orbia.com

**Identification of the assembled product:**

- FLEX

**Identification of the authorized modular components used in the assembly:**

- Modular 1, FCC ID: XMR201906EG21G
- Modular 2, FCC ID: 2AC7Z-ESPC3WROOM3

**Copies of Compliance Statements for each SDoC modular component used:**

- Modular 1, FCC ID: XMR201906EG21G
- Modular 1, FCC ID: 2AC7Z-ESPC3WROOM3

**Standards applied:**

- FCC Part 15B - For Unintentional radiators (test report number: GTS2024070035F01)

**Test reports/ certificates issued by:** Global United Technology Services Co., Ltd.

**Applicable Compliance Statements:**

(§15.19(a)(3): This device complies with related rules, operation is subject to the following two conditions: (1). This device may not cause harmful interference and, (2). This device must accept any interference received, including interference that may cause undesired operation.

As the manufacturer's authorized representative within the USA, we declare under our sole responsibility that the equipment follows the provisions of FCC Equipment Authorization Procedure 47 CFR §2.906 - SUPPLIER'S DECLARATION OF CONFORMITY as stated above.

The following responsible party designated in FCC 47 CFR §2.909 is responsible for this declaration.

Thus **FC** is placed on the product

Date of issue: Mar 5, 2025

Place of issue: Fresno, California

\_\_\_\_\_  
Mike Hemman

Mike Hemman,  
President Netafim North America

DocuSign Envelope ID: 8B78A166-90B1-40C4-8010-BB0C1A09CA89



## FCC SUPPLIER'S DECLARATION OF CONFORMITY

We Netafim Ltd, declare:

**Types of equipment:** Irrigation and fertigation controller

**Brand name or trademark:** GrowSphere

**Product name:** GS-MAX-DD-110V-6DO-12DI

**Country of origin:** Israel

**Manufacturer:** Netafim Ltd

**Responsible Party name (IN USA):** Mike Hemman

- Address: 4570 E. Home Ave., Fresno, CA 93727
- Telephone: (559) 250-3632
- E-Mail: Mike.hemman@netafim.orbia.com

**Identification of the assembled product:**

- GS-MAX-DD-110V-6DO-12DI

**Identification of the authorized modular components used in the assembly:**

- Modular 1, FCC ID: XMR201903EG25G
- Modular 2, FCC ID: 2AET4RUT241AF

**Copies of Compliance Statements for each SDoC modular component used:**

- Modular 1, FCC ID: XMR201903EG25G
- Modular 1, FCC ID: 2AET4RUT241AF

**Standards applied:**

- FCC Part 15B - For Unintentional radiators (test report number: GTS2023110170F02)
- FCC Part 15C.22 - For Intentional radiators (test report number: GTS2023110170F01)

**Test reports/ certificates issued by:** Global United Technology Services Co., Ltd.

**Applicable Compliance Statements:**

(§15.19(a)(3): This device complies with related rules, operation is subject to the following two conditions: (1). This device may not cause harmful interference and, (2). This device must accept any interference received, including interference that may cause undesired operation.

As the manufacturer's authorized representative within the USA, we declare under our sole responsibility that the equipment follows the provisions of FCC Equipment Authorization Procedure 47 CFR §2.906 - SUPPLIER'S DECLARATION OF CONFORMITY as stated above.

The following responsible party designated in FCC 47 CFR §2.909 is responsible for this declaration.

Thus **FC** is placed on the product

Date of issue: Mar 5, 2025

Place of issue: Fresno, California

\_\_\_\_\_  
Mike Hemman

Mike Hemman,  
President Netafim North America



DocuSign Envelope ID: 8B78A166-90B1-40C4-8010-BB0C1A09CA89



## FCC SUPPLIER'S DECLARATION OF CONFORMITY

We Netafim Ltd, declare:

**Types of equipment:** Irrigation and fertigation controller

**Brand name or trademark:** GrowSphere

**Product name:** GS-MAX-DISP-110V-6DO-12DI

**Country of origin:** Israel

**Manufacturer:** Netafim Ltd

**Responsible Party name (IN USA):** Mike Hemman

- Address: 4570 E. Home Ave., Fresno, CA 93727
- Telephone: (559) 250-3632
- E-Mail: Mike.hemman@netafim.orbia.com

**Identification of the assembled product:**

- GS-MAX-DISP-110V-6DO-12DI

**Identification of the authorized modular components used in the assembly:**

- Modular 1, FCC ID: XMR201903EG25G
- Modular 2, FCC ID: 2AET4RUT241AF

**Copies of Compliance Statements for each SDoC modular component used:**

- Modular 1, FCC ID: XMR201903EG25G
- Modular 1, FCC ID: 2AET4RUT241AF

**Standards applied:**

- FCC Part 15B - For Unintentional radiators (test report number: GTSL2024030084F01)
- FCC Part 15C.22 - For Intentional radiators (test report number: GTS2023110170F01)

**Test reports/ certificates issued by:** Global United Technology Services Co., Ltd.

**Applicable Compliance Statements:**

(§15.19(a)(3): This device complies with related rules, operation is subject to the following two conditions: (1). This device may not cause harmful interference and, (2). This device must accept any interference received, including interference that may cause undesired operation.

As the manufacturer's authorized representative within the USA, we declare under our sole responsibility that the equipment follows the provisions of FCC Equipment Authorization Procedure 47 CFR §2.906 - SUPPLIER'S DECLARATION OF CONFORMITY as stated above.

The following responsible party designated in FCC 47 CFR §2.909 is responsible for this declaration.

Thus **FC** is placed on the product

Date of issue: Mar 5, 2025

Place of issue: Fresno, California

  
Mike Hemman,  
President Netafim North America

DocuSign Envelope ID: 8B78A166-90B1-40C4-8010-BB0C1A09CA89



## FCC SUPPLIER'S DECLARATION OF CONFORMITY

We Netafim Ltd, declare:

**Types of equipment:** Irrigation and fertigation controller

**Brand name or trademark:** GrowSphere

**Product name:** GS-MAX-NO\_DISP-110V-6DO-12DI

**Country of origin:** Israel

**Manufacturer:** Netafim Ltd

**Responsible Party name (IN USA):** Mike Hemman

- Address: 4570 E. Home Ave., Fresno, CA 93727
- Telephone: (559) 250-3632
- E-Mail: Mike.hemman@netafim.orbia.com

**Identification of the assembled product:**

- GS-MAX-NO\_DISP-110V-6DO-12DI

**Identification of the authorized modular components used in the assembly:**

- Modular 1, FCC ID: XMR201903EG25G
- Modular 2, FCC ID: 2AET4RUT241AF

**Copies of Compliance Statements for each SDoC modular component used:**

- Modular 1, FCC ID: XMR201903EG25G
- Modular 1, FCC ID: 2AET4RUT241AF

**Standards applied:**

- FCC Part 15B - For Unintentional radiators (test report number: GTS2023110190F02)
- FCC Part 15C.22 - For Intentional radiators (test report number: GTS2023110170F01)

**Test reports/ certificates issued by:** Global United Technology Services Co., Ltd.

**Applicable Compliance Statements:**

(§15.19(a)(3): This device complies with related rules, operation is subject to the following two conditions: (1). This device may not cause harmful interference and, (2). This device must accept any interference received, including interference that may cause undesired operation.

As the manufacturer's authorized representative within the USA, we declare under our sole responsibility that the equipment follows the provisions of FCC Equipment Authorization Procedure 47 CFR §2.906 - SUPPLIER'S DECLARATION OF CONFORMITY as stated above.

The following responsible party designated in FCC 47 CFR §2.909 is responsible for this declaration.

Thus **FC** is placed on the product

Date of issue: Mar 5, 2025

Place of issue: Fresno, California

  
Mike Hemman,  
President Netafim North America



## 4. Quick Start Guide

1/ Internal Design

5/ Wiring & Expantions

2/ Local & remote control

6/ Connect to Remote Unit

3/ System Prefrences

7/ Dosing Settings

4/ System Settings

8/ Create Irrigation Program



## 4.1 Internal design

### / GrowSphere™ MAX - Internal design

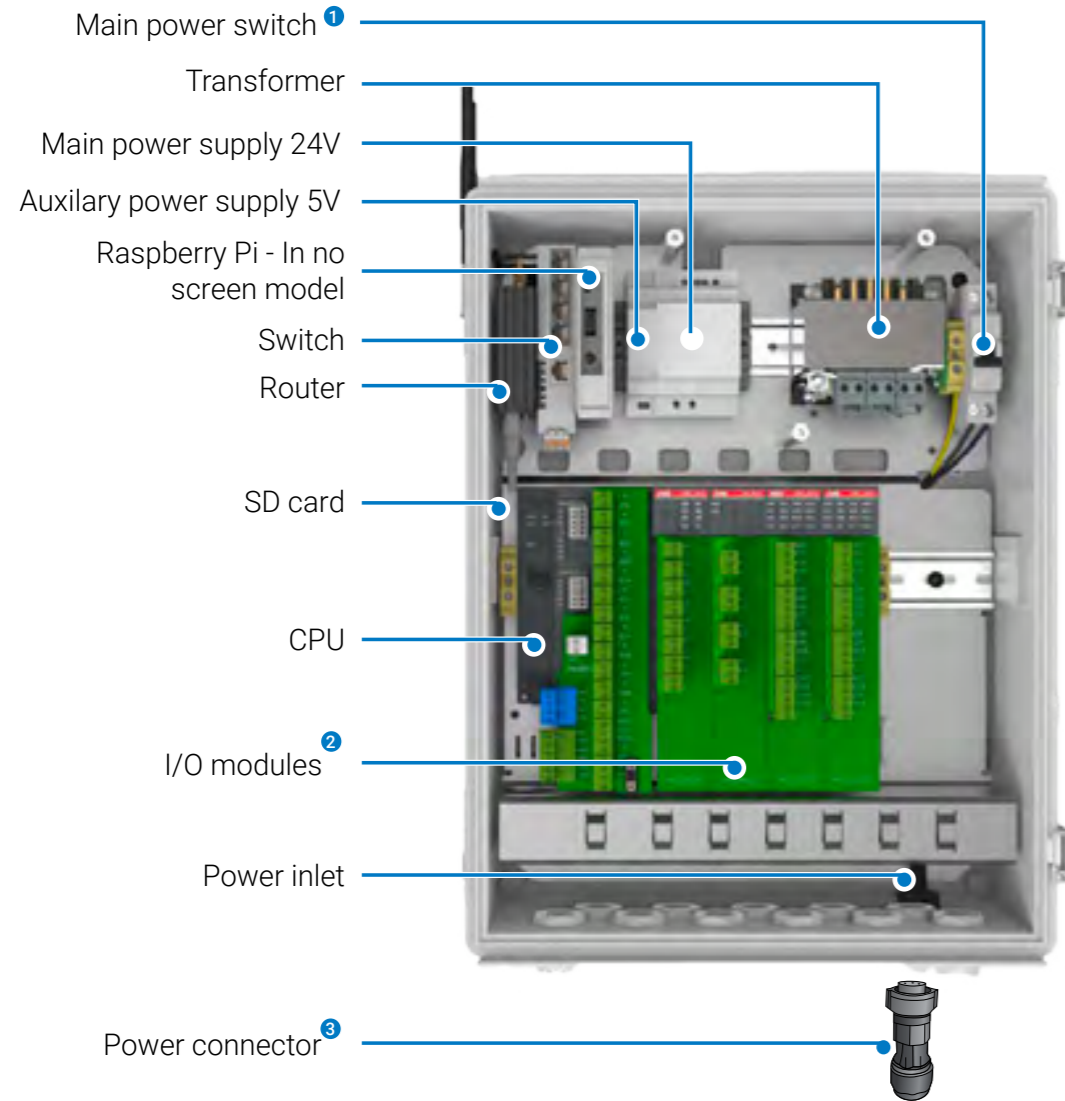

### / GrowSphere™ MAX - CPU

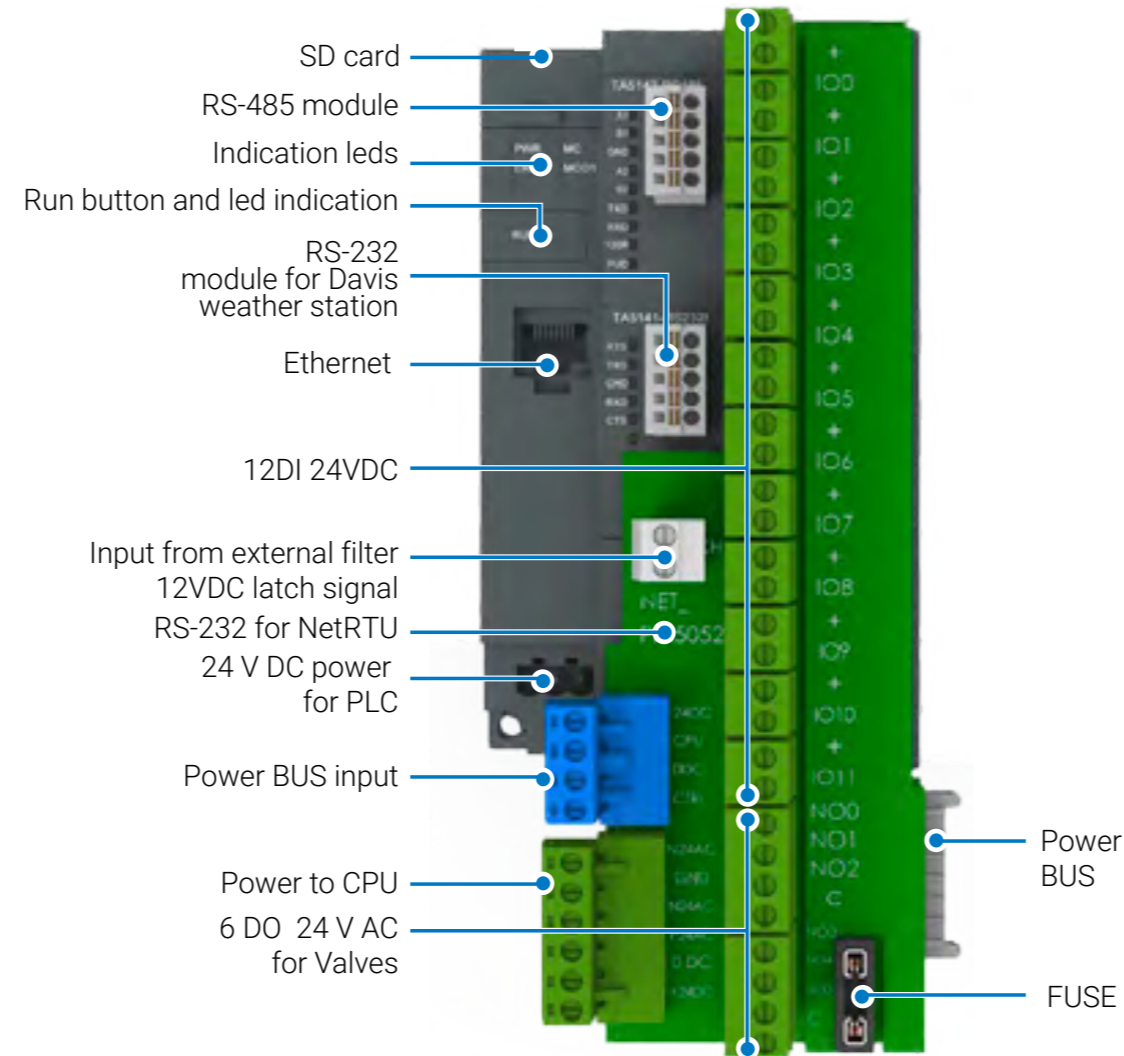

#### CPU Adaptor features

- AC protection Fuse
- CPU remote reset
- Controlled by modem remotely
- Easy visual indication
- 24AC LED
- 24DC LED
- CPU reset

#### Custom ABB controller

- Memory 80MB

### Main functionalities of the internal components

**Main Power Switch** - Switch the main power on and off.

**Transformer** - Transform AC to DC. CPU gets its power before the transformer.

**Main power supply 24V** - Provides the power to the CPU, screen, and Modem.

**Auxiliary power supply 5V** - Provides the power to the Gateway and for Davis weather station.

**Raspberry Pi - Contains the Anydesk** - for remote control through Anydesk. Supplied with the screen-less models only.

**Switch** - Connect to the controller locally via LAN or to the internet. Also, it improves modem stabilization.

**Router** - Contains the SIM card and enables communication to the internet.

**SD Card** - Back up of data and version upgrade.

**I/O Modules** - Enables connection of the peripheral components. Up to six modules can be connected to the MAX simultaneously.

**Power connector** - The connector can be found in the accessories box.

### Expansion modules

**Four types of expansion modules can be connected to the GrowSphere™ MAX**

- ① Switches the main power on and off
- ② Enable connecting the peripheral components
- ③ You can find the connector in the accessories box

\* Subject to product configuration



/ **GrowSphere™ MAX Power**

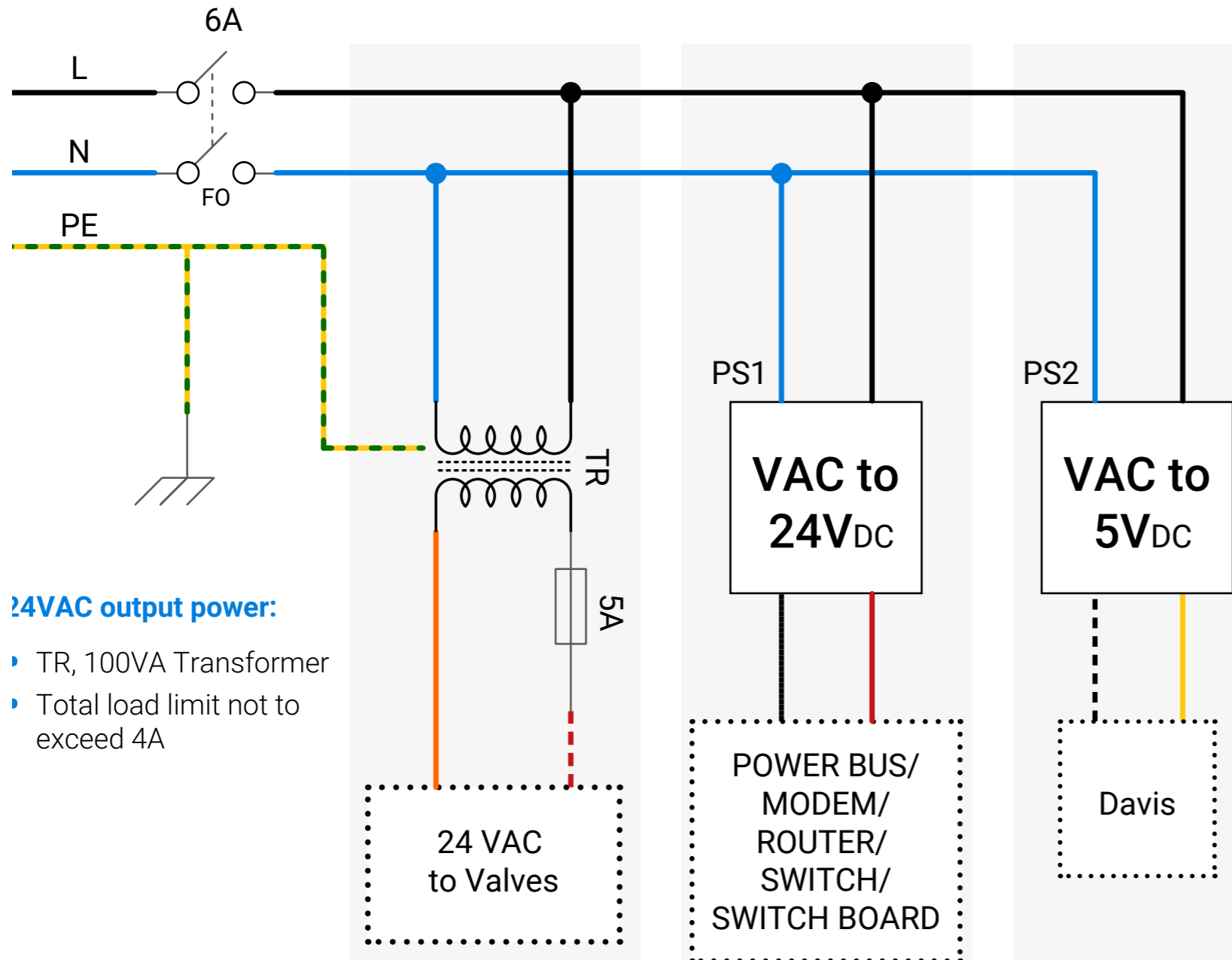

**24VAC output power:**

- TR, 100VA Transformer
- Total load limit not to exceed 4A

/ **GrowSphere™ MAX Power connector**

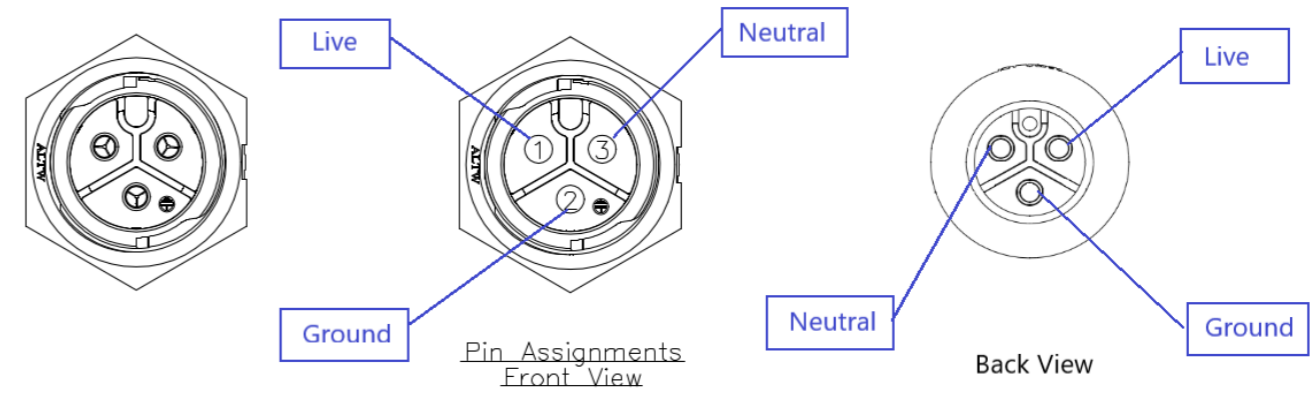

/ **GrowSphere™ MAX Cable connector**

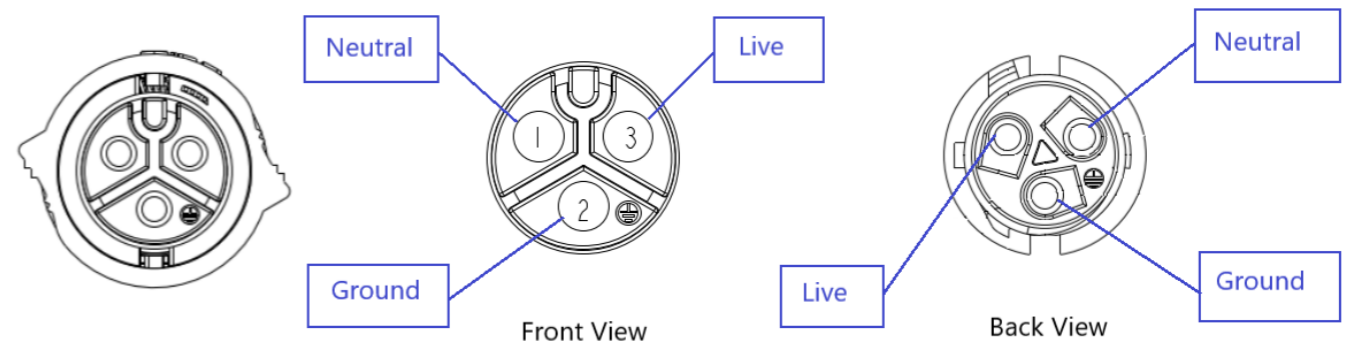

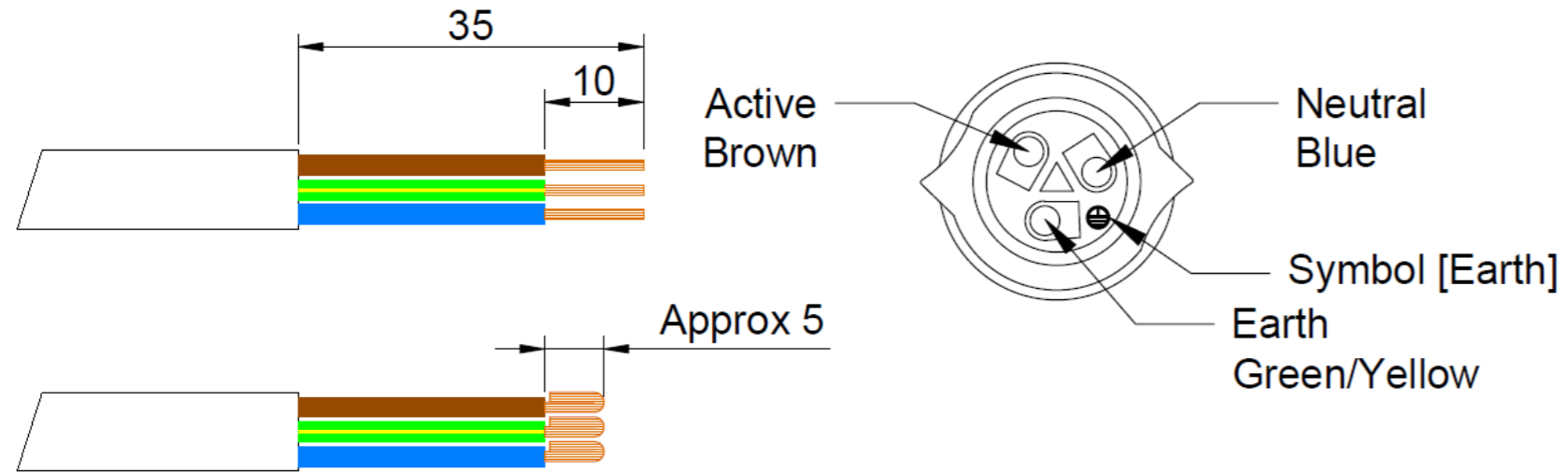

Double the bare wire over before inserting into the terminal. Up to 1mm<sup>2</sup>

### / Screw-In Type Assembly Instruction



## / Firmware Upgrade using SD card

To upgrade the firmware in your GrowSphere™ MAX controller, follow these steps below. Remember to stay up to date with future firmware versions.

1. Turn OFF GS Max, takeout existing SD Card
2. Prepare a clean SD card formatted with FAT32
3. Download required latest version. Unzip it to a folder.
4. Copy only the content of the folder into SD card root.
5. The SD card contents should look like:

Name	Type
FIRMWARE	File folder
USERDATA	File folder
SDCARD.INI	Configuration settings
Version.txt	Text Document
Version.txt.sig	SIG File

6. Insert this SD card into PLC
7. Power ON the PLC.
8. If a new FW is found on the SD card, RUN and ERR LEDs will start blinking in 1 HZ
9. Wait ~5min until only the RUN LED is blinking.
10. Power OFF the PLC .
11. Take out the SD card and insert SD card that was taken out from PLC before upgrade or it may be empty card.
12. Power ON the PLC.
13. The controller will reboot once again automatically, wait the process to complete. When the process complete, the RUN LED should remain constantly on. When the process complete, the RUN LED should remain constantly on.
14. if the process is successful RUN LED should be constantly on (ERR LED might be red, that is OK , MC LED will be ON, if SD Card is inserted in the slot).

## / Remote FW Upgrade (FOTA)

The FOTA process consists of 2 steps: 1) from the Admin portal, 2) from the controller.

### Preparations

Before starting the process ensure that Start and End time of the day is checked, under Settings → Preferences → System Definitions, for each mainline.

The download from cloud will take place only out of hours when there is no irrigation activity. The download process occurs in the background and takes ~2 hours.

### Process starts on cloud.

From the **Admin, Device Management**, select the MAX controller you wish to upgrade.

Mark the FOTA checkbox for the device and press the **FOTA** button that appears on the top menu bar.

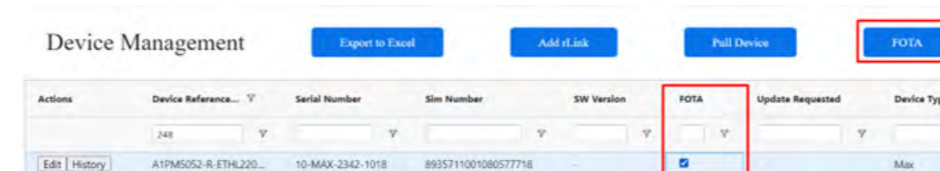

On the Popup window, select the version and the time to upgrade and approve the process.

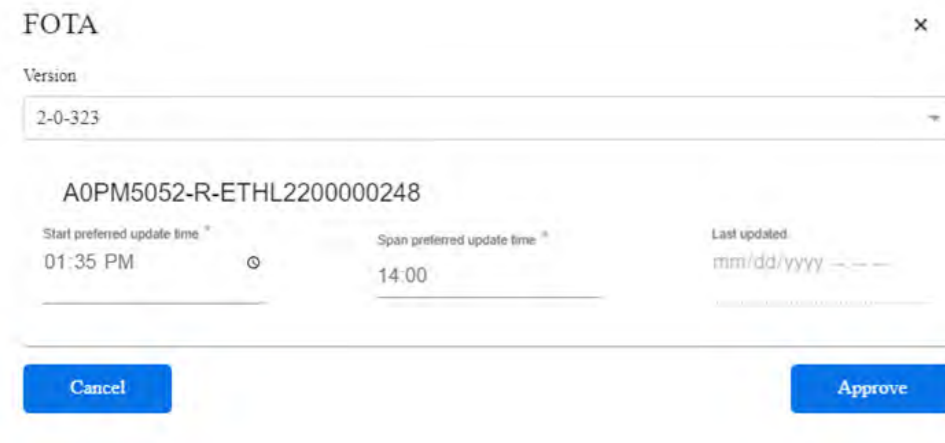

Wait for the file to be downloaded to the controller SD card.

Once the download is completed, the following message will pop up.

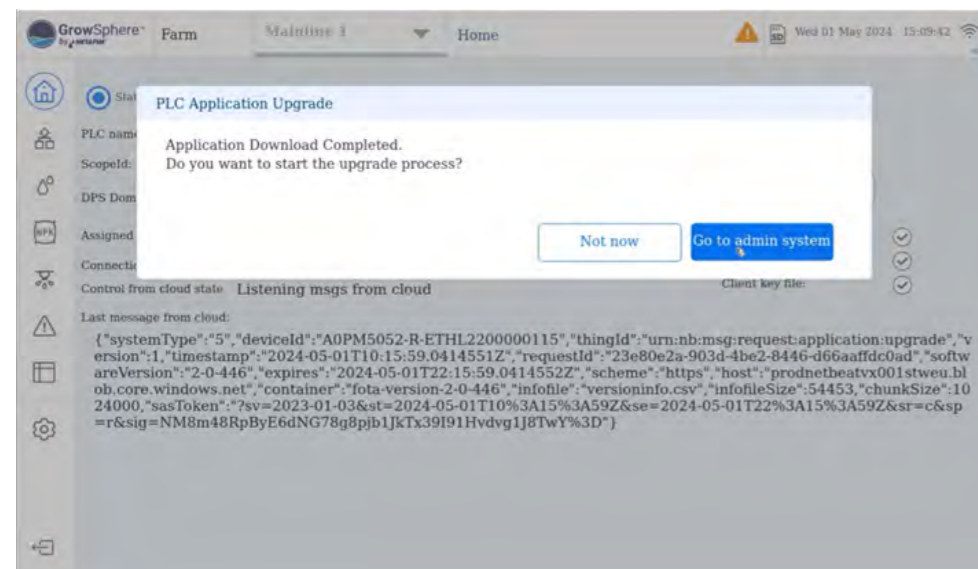

Press on the “Go to admin → system” button, this will take you to the admin section, you will need the password: 287451 to access this page.

On the **Admin** screen, system tab you will find the button “Upgrade System” press it to start the upgrade.

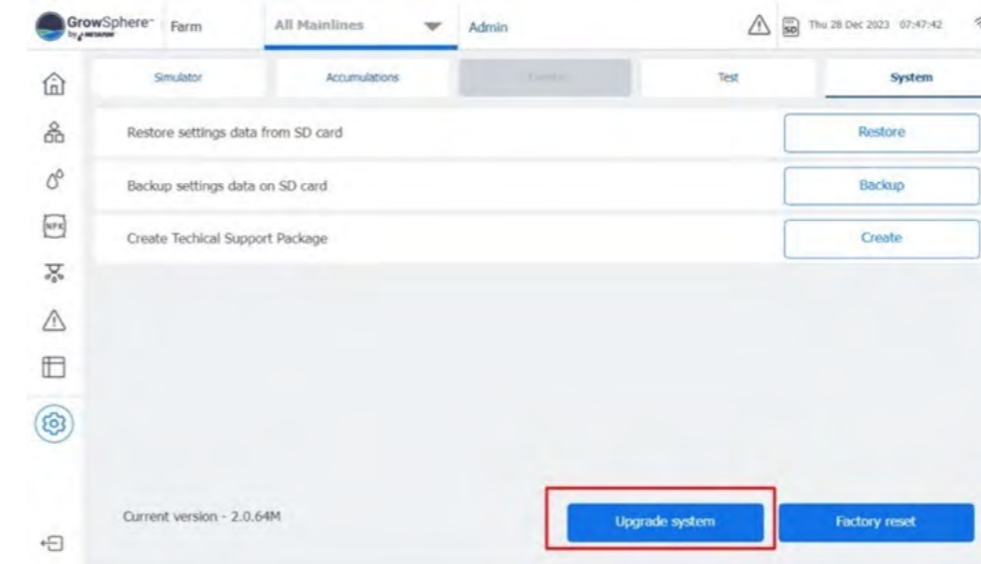

After pressing the “Upgrade System” the following popup will appear, when all steps appear with green check, press the “Restart” button, otherwise the controller will reboot after 10 minutes.

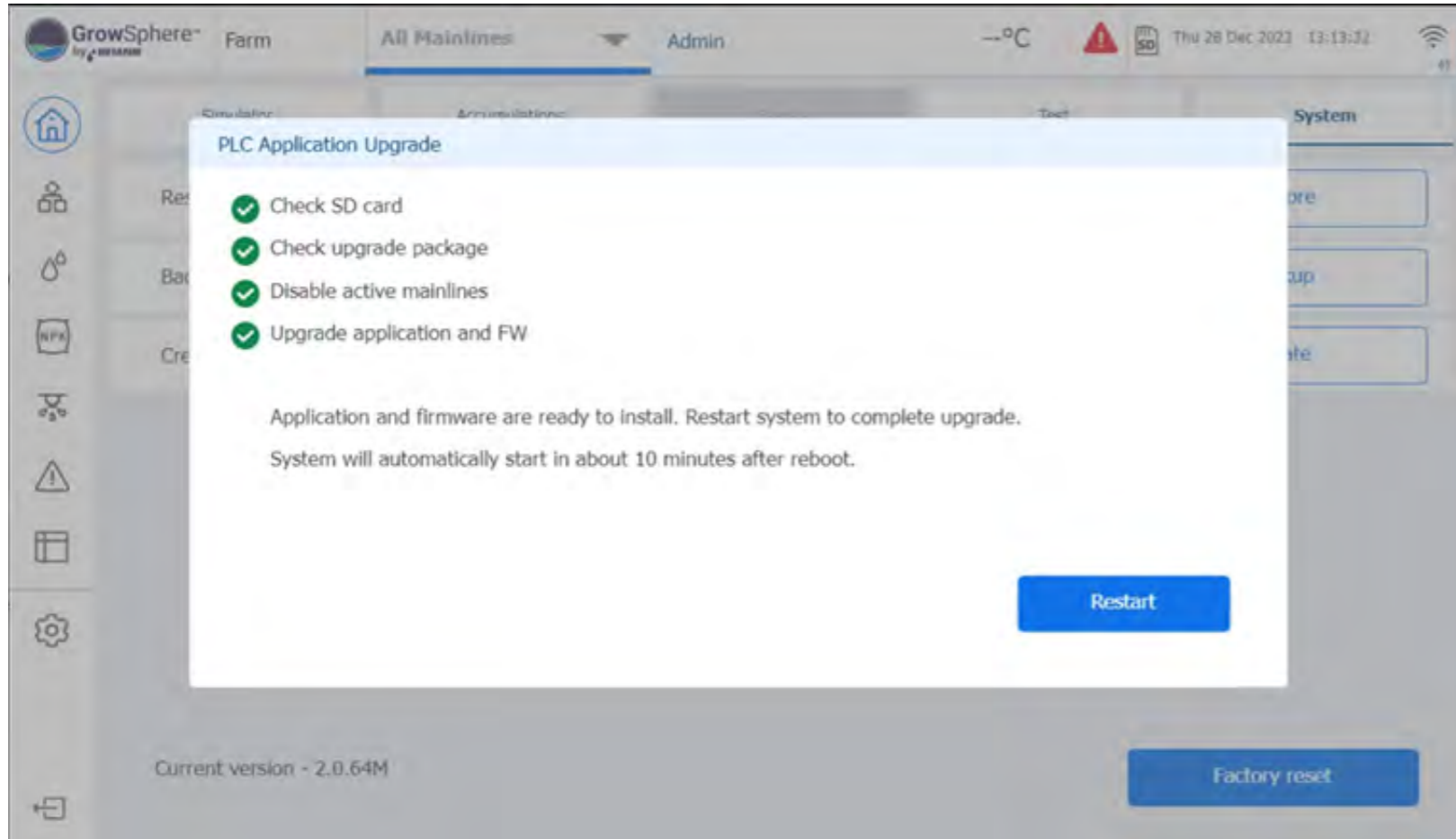

At the end of the process the controller screen will load with the new version. The new version can also be seen on Settings → Admin → System.

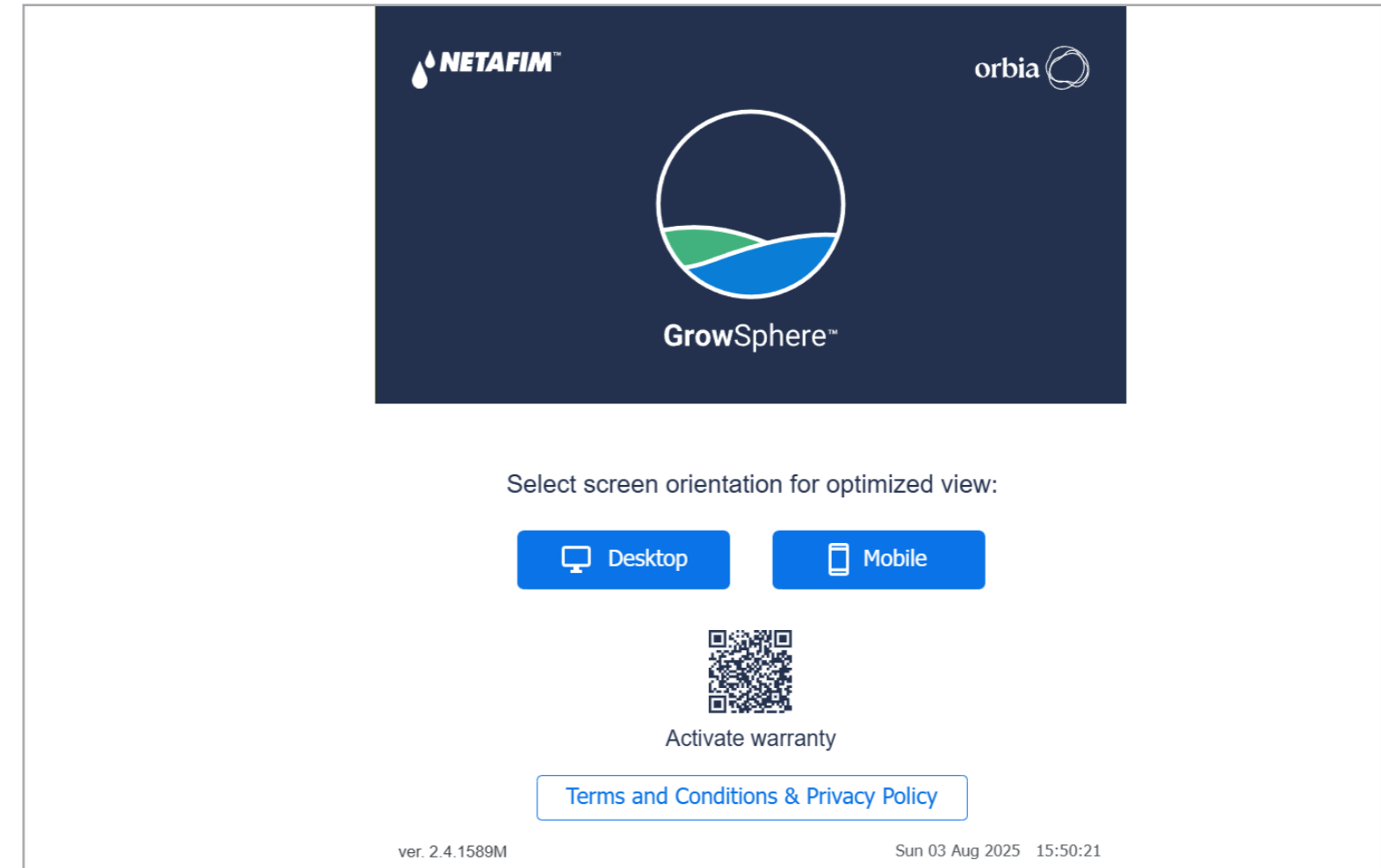

## 4.2 Local and remote control

For local access, you can connect to the controller' Wi-Fi by scanning the QR code on the controller or connect via LAN. To access remotely, you can use **GrowSphere™** Cloud by clicking on the link icon or use Anydesk from any device by entering the username and password provided with the controller.

### / Local access via LAN

1. Create static IP address – for example: the address range of the system is 192.168.0.4
2. Ensure the Default gateway address is: 192.168.0.10
3. Connect a LAN cable to the switch and type the IP address 192.168.0.10 in the URL

Navigate to your ethernet port properties and set the TCP/IPv4 option, as demonstrated below

To easily find your Ethernet port, navigate to the Control Panel > Network and Sharing Center > Change adapter settings

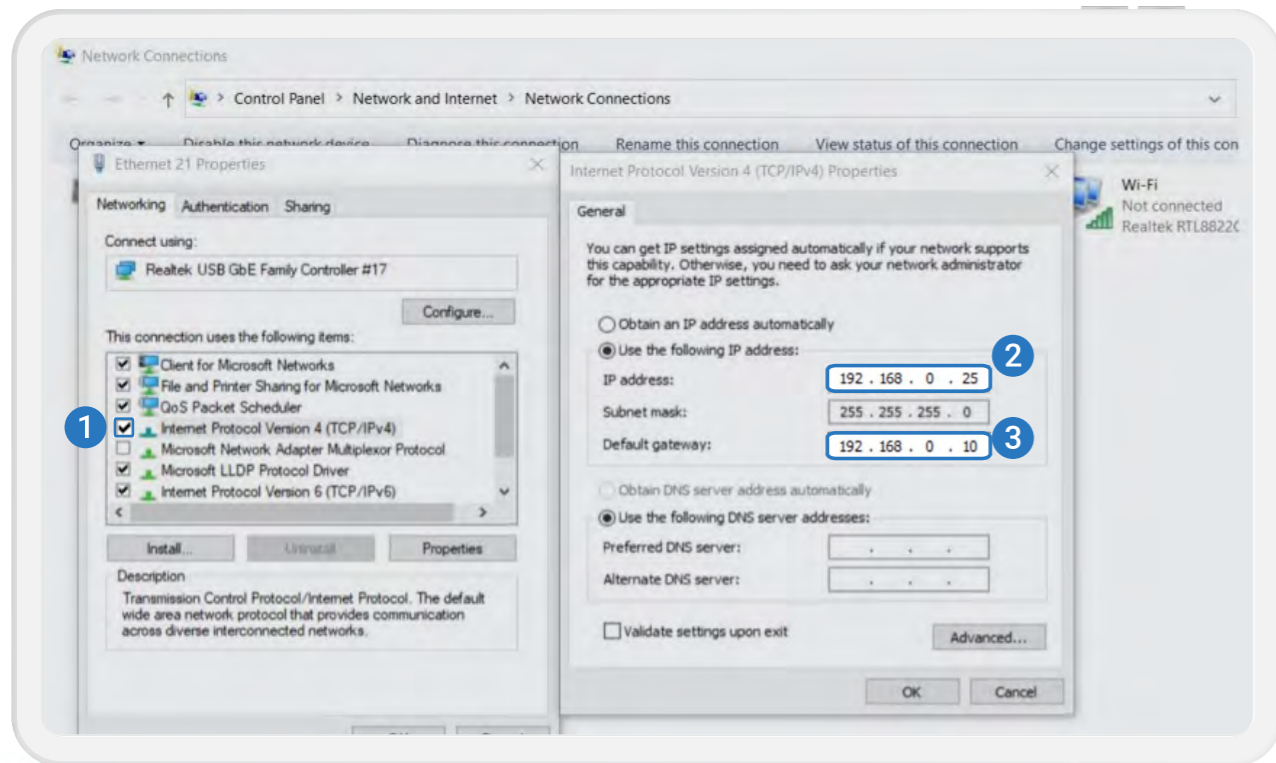

/ Local access via WIFI

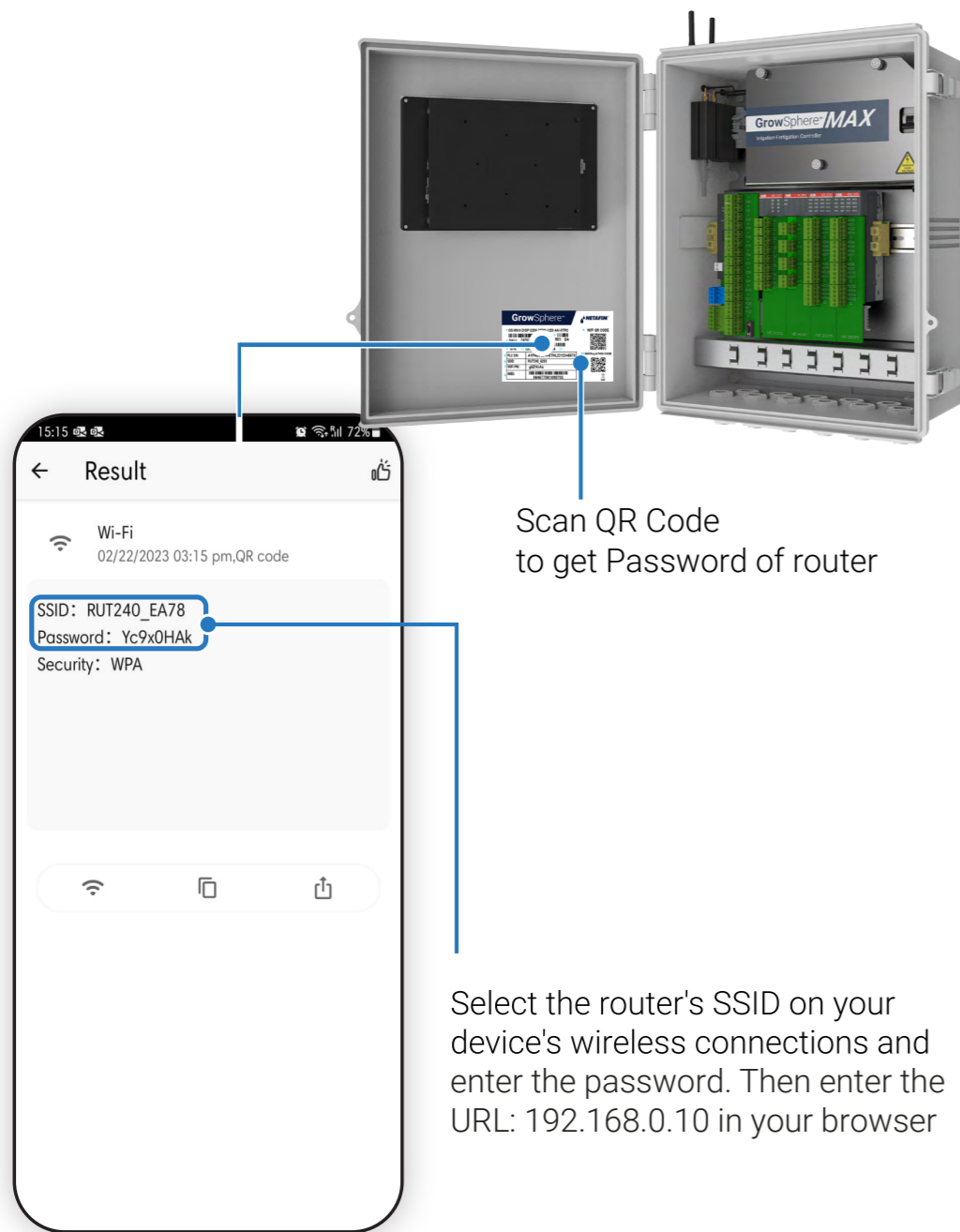

- By typing 192.168.0.10 in the URL line, you will be able to access to the controller dashboard.
- By scanning the QR code on the controller you will get the Wi-Fi address and password for the controller's modem.



## / Remote access - Using Anydesk

The controller comes with a SIM card and can be accessed through the **GrowSphere™** Cloud. However, you can also access it through AnyDesk by following these two steps:

To get started, you'll need to install Anydesk on your computer, tablet, or mobile device. Once you have it installed, you can use the AnyDesk ID found on the controller's internal door. The passwords for anydesk is **GrowSphere01**.

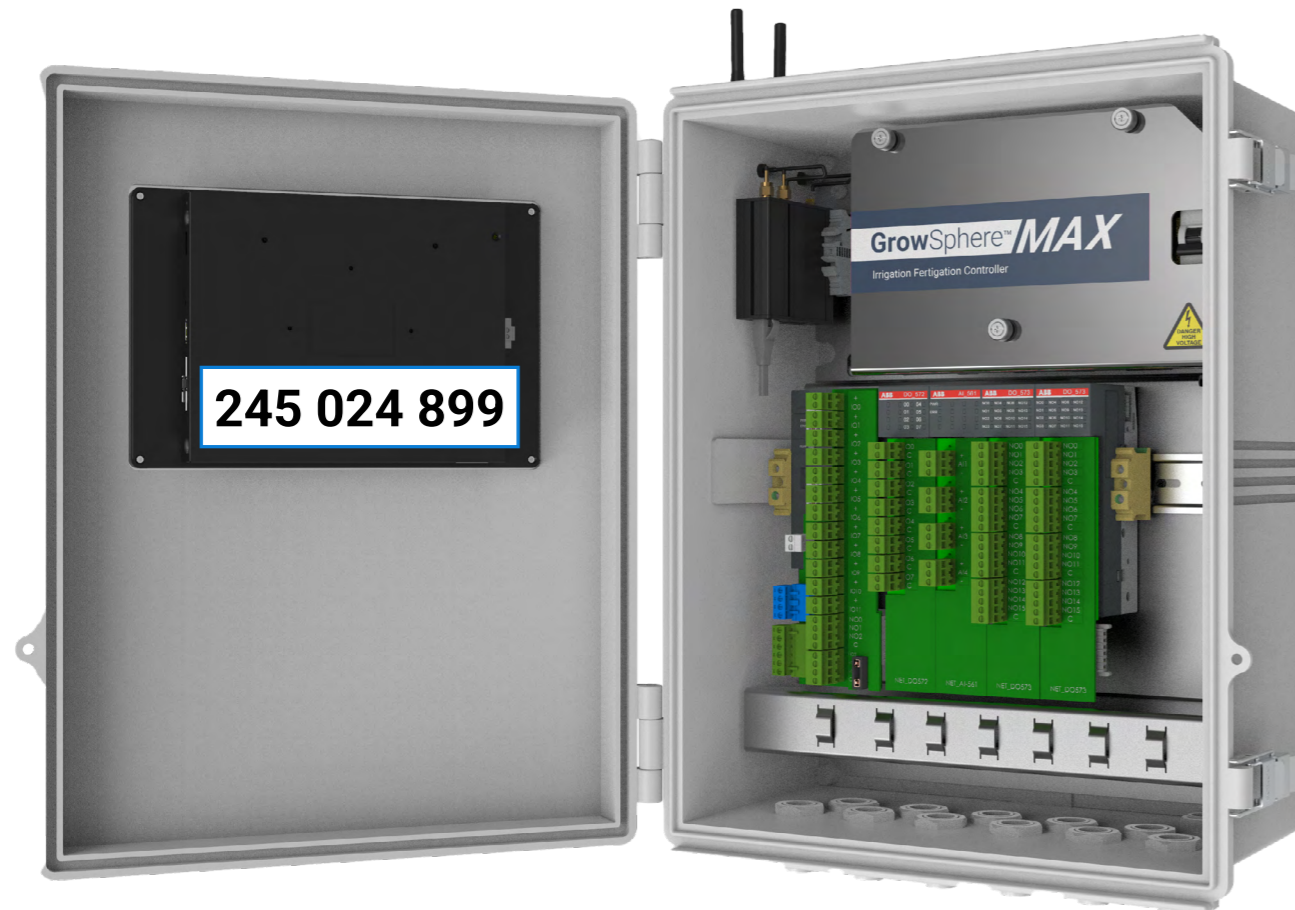

## GrowSphere™ MAX - Basic Settings

### / Getting started

Select the Desktop or Mobile view.

In the case of Tablet, it is recommended to select Desktop.

Mobile view is recommended when connecting to the controller from **GrowSphere™** Mobile app.

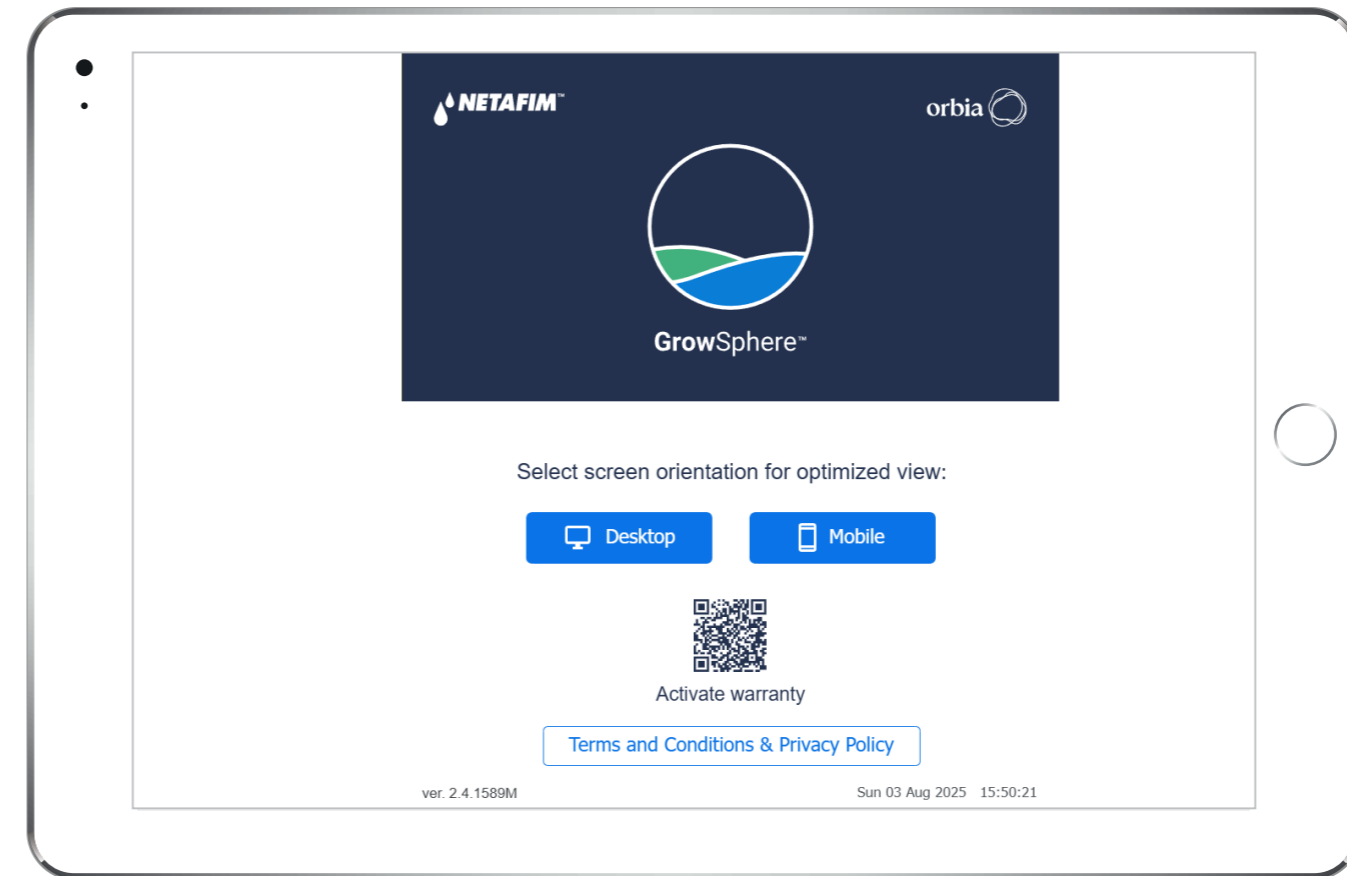

\* For more information of the available functions in the Mobile view, please see chapter 5.1.2



## 4.3 System preferences

### / Remote access - Using Anydesk

Set your preferences and continue to the next step, your settings will be saved automatically

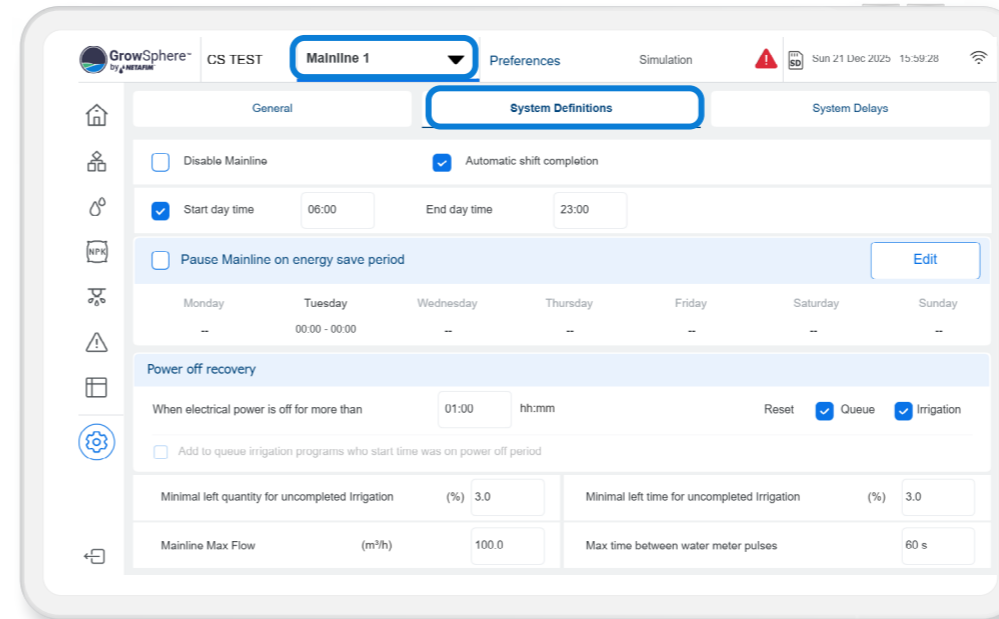
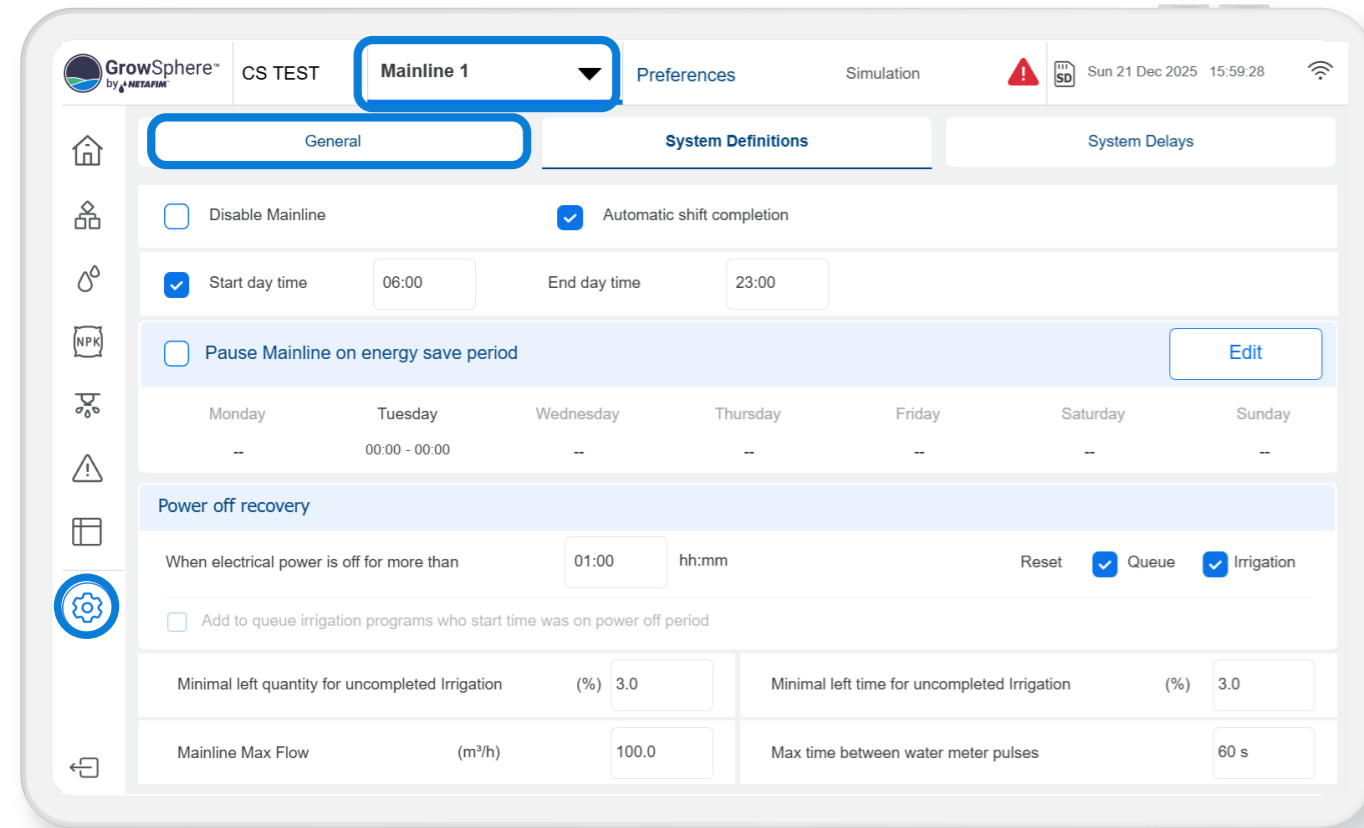

### / Set definitions for operation time and flow

Select the relevant mainline – From this stage, all the settings will be per mainline.

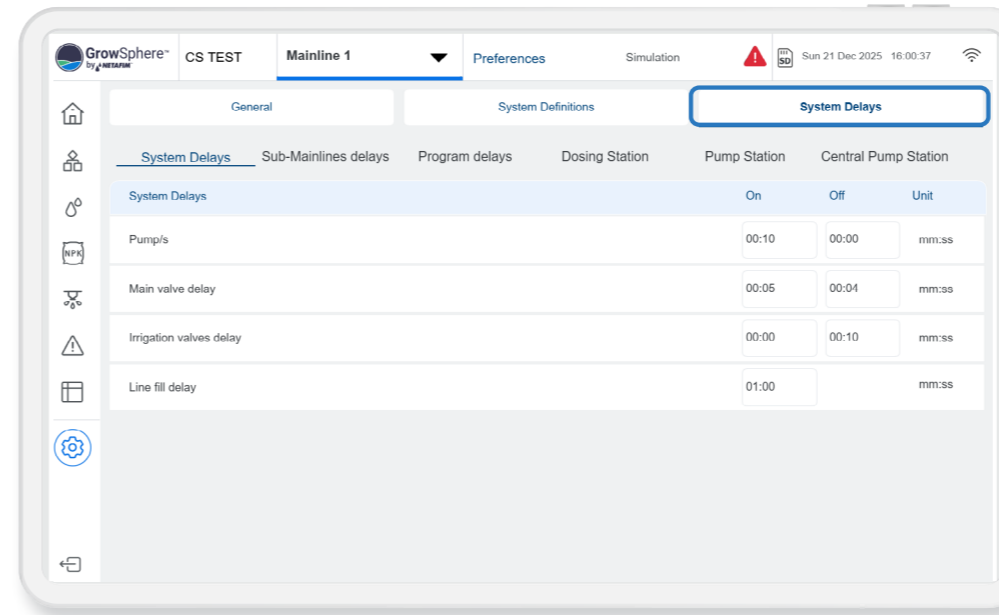

### / Define system delays

Set the delays for the mainline components



## 4.4 System settings

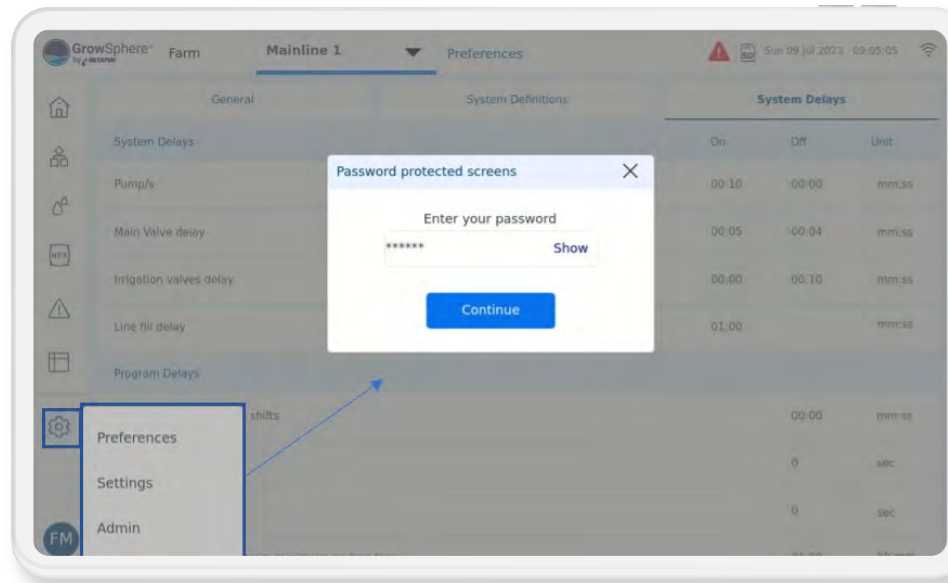

### / Navigate to settings

Enter the password 287451

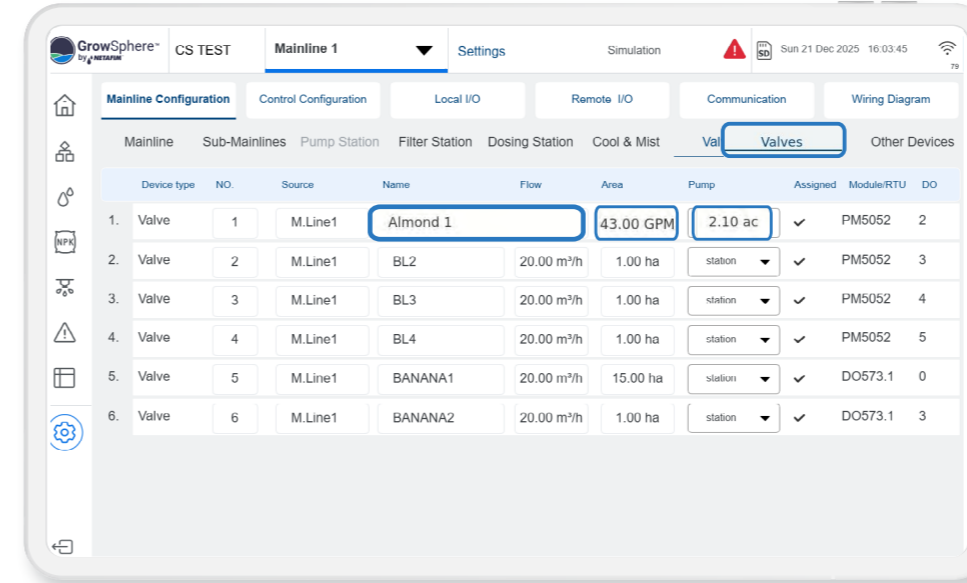

### / Set valves configurations

- Set name, flow rate, and irrigated area for each valve
- The Flow and Area are used to manage and monitor the irrigation in the **GrowSphere™** cloud, therefore, must reflect the real size of each irrigation plot (field)

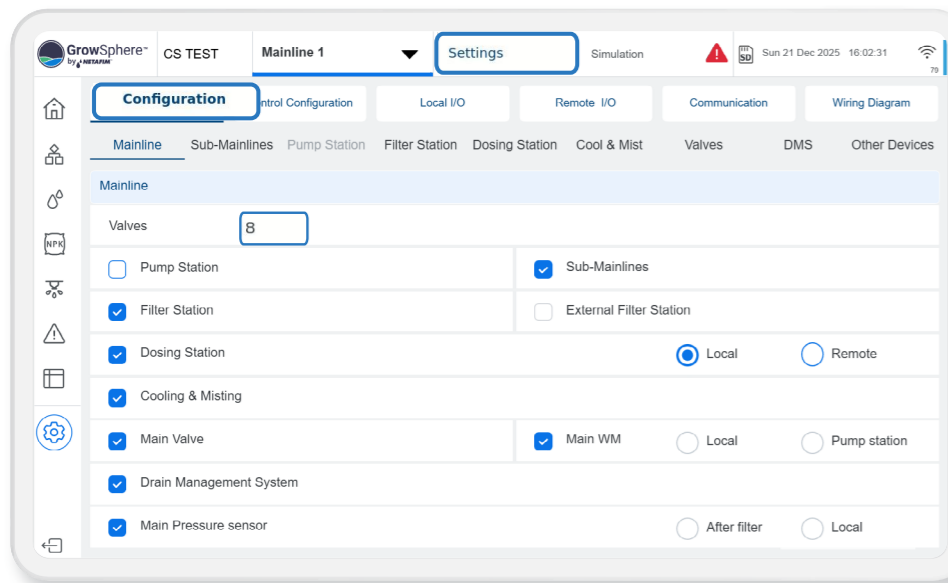

### / Set mainlines configuration

Define the number of valves and the devices that connected to each mainlines

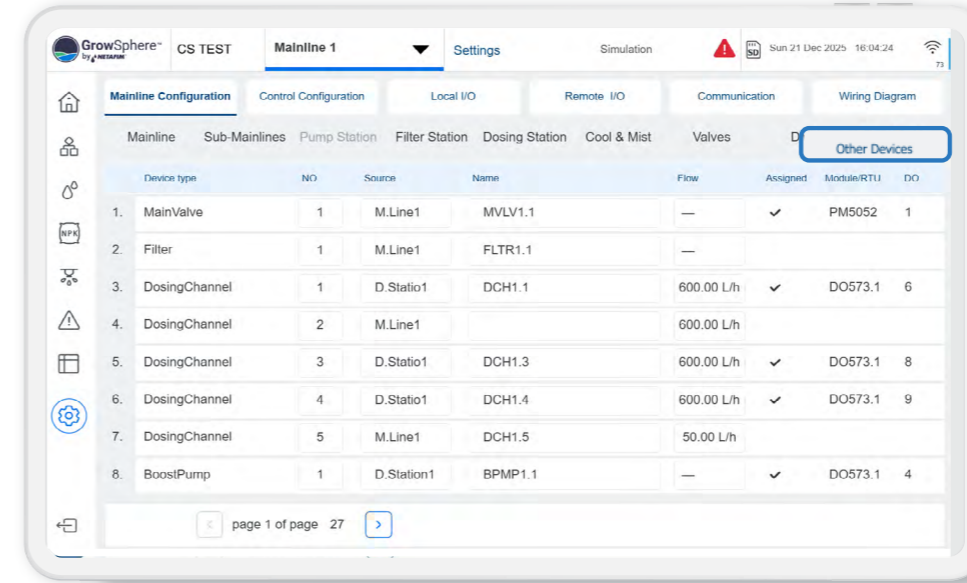

### / Define other devices configurations

Set the parameters for each device



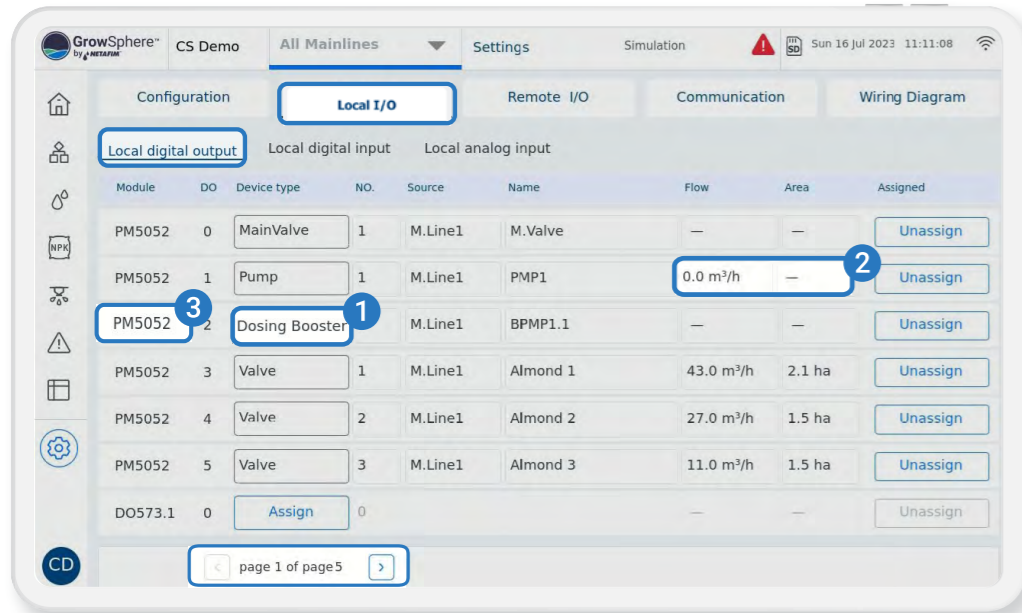

### / Assign digital outputs to I/O modules

1. Click assign for each row to assign the device to the available port in each module
2. Define the Flow and irrigated area for each valve
3. The I/O module to which the device has been assigned to can be selected by skip between pages 1-5

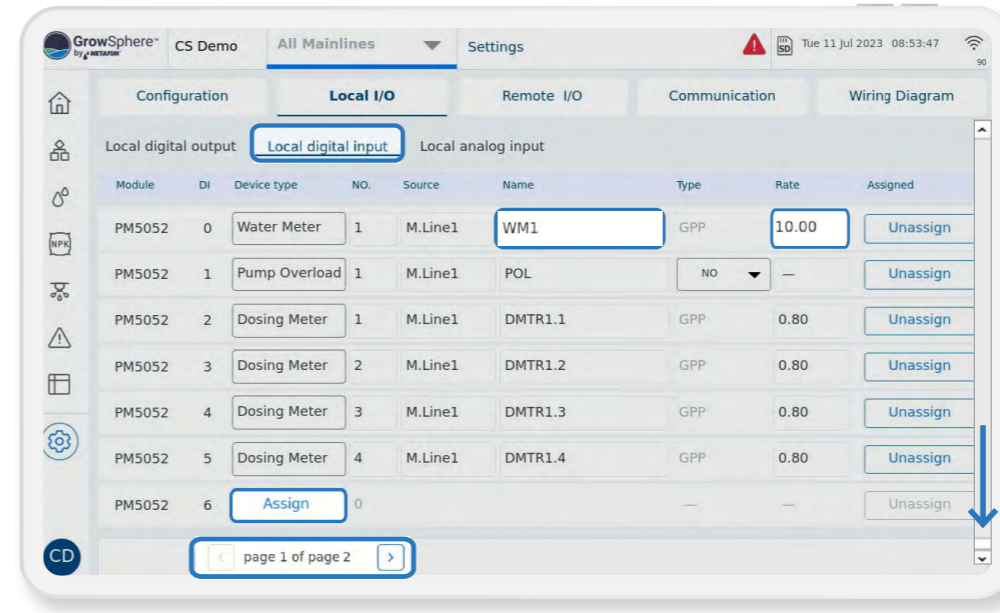

### / Assign digital inputs to I/O module

- Assign each device to I/O Module and port
- Provide the name, flow rate, and irrigated area for each input
- You can select the I/O module to which the device has been assigned by navigating between pages 1-5

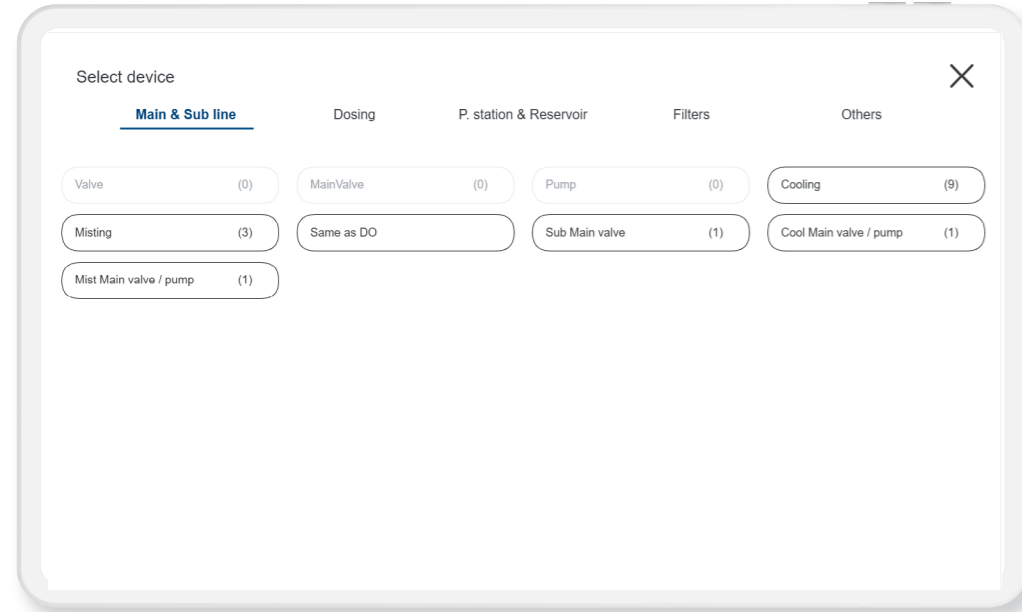

### / Assign digital outputs to I/O modules

By clicking Assign, the system will indicate how many devices are not yet assigned, and will automatically assign it to the next available port

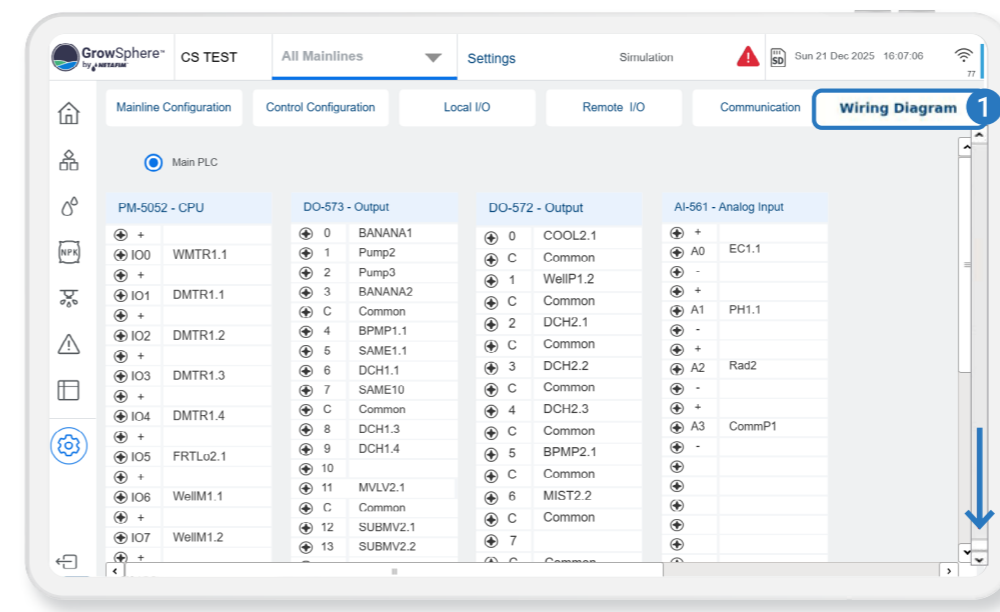

### / View the wiring diagram

The wiring diagram shows the module and port for each device that has been assigned. You can follow the diagram to properly wire the local devices



## 4.5 Wiring instructions

### / GrowSphere™ MAX - CPU

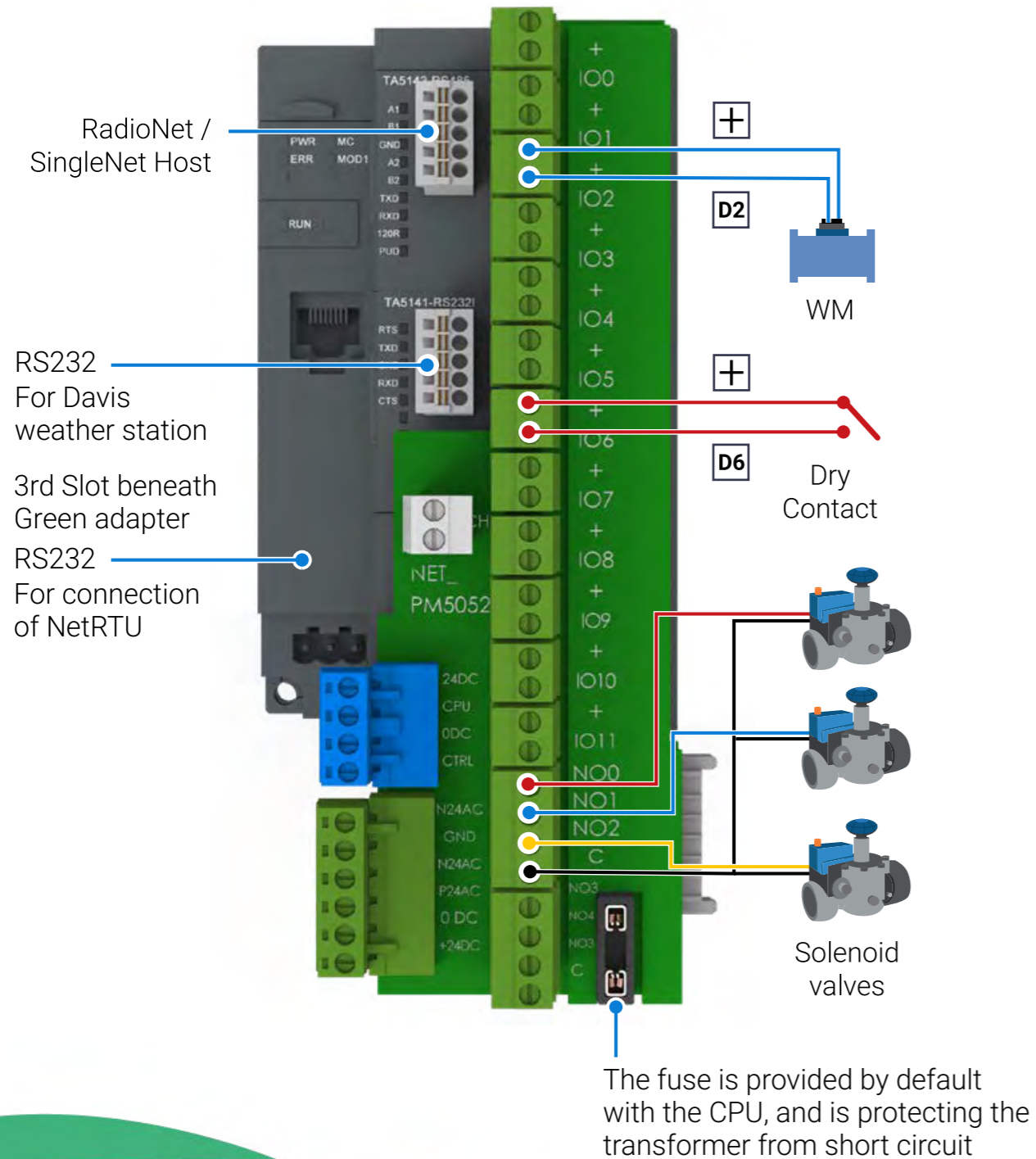

## Expansion modules

### / D0573 module

- 16 normally open relay outputs
- Output current per channel = 2 A
- Indication of output signals – 1 yellow LED per ch.

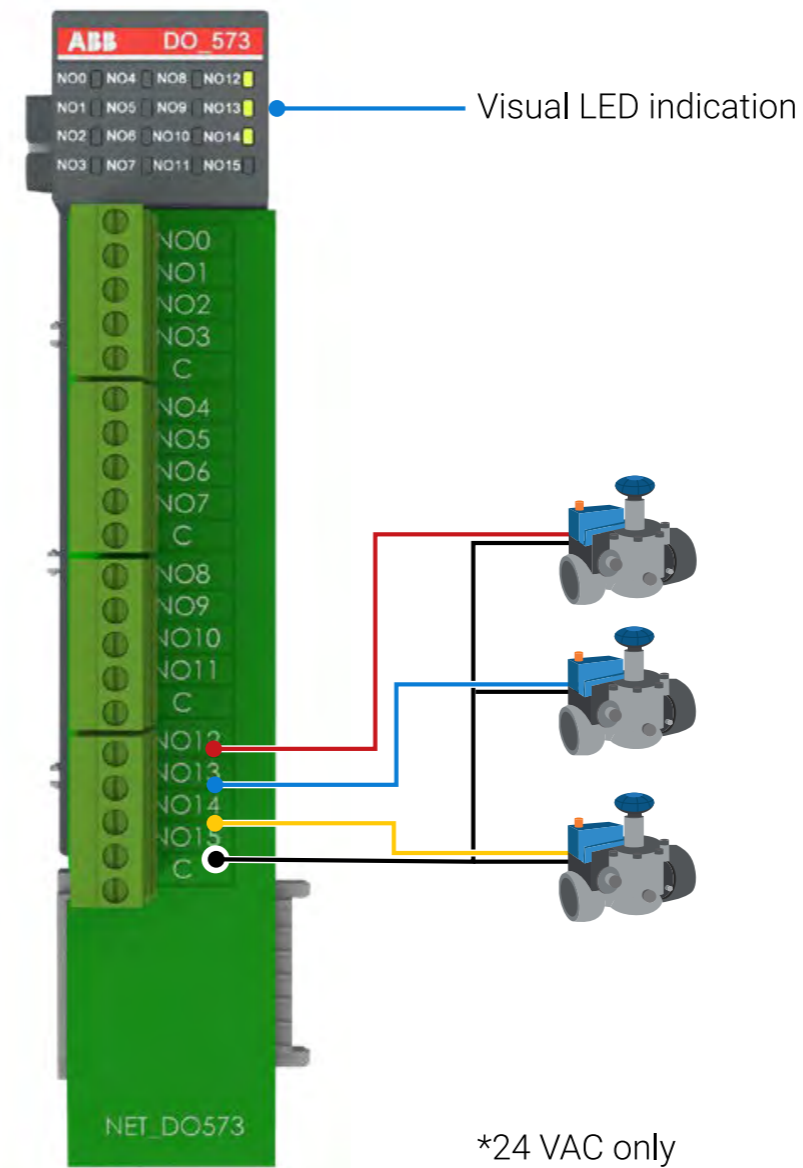

## / AI561/568 Module

- 4/8 analog inputs
- Feed (Sourcing) voltage – 24 VDC
- Resolution – 0-20mA; 4 -20mA; 12 bit
- Channel input resistance – 250 ohm
- General Purpose of only EC, pH
- Pressure sensor
- General sensor 4-20mA

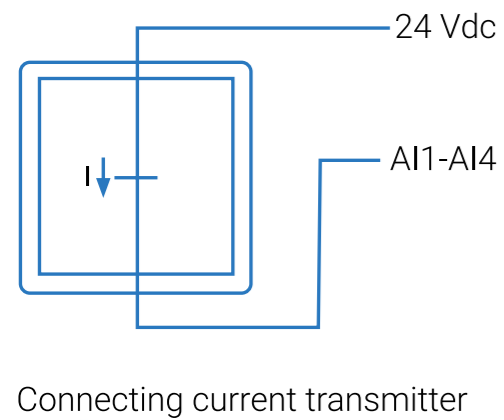
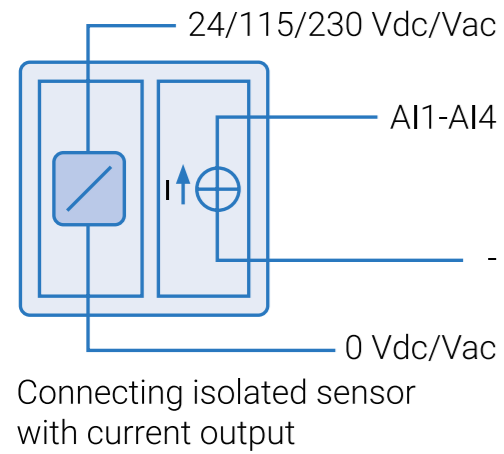

4 analog inputs

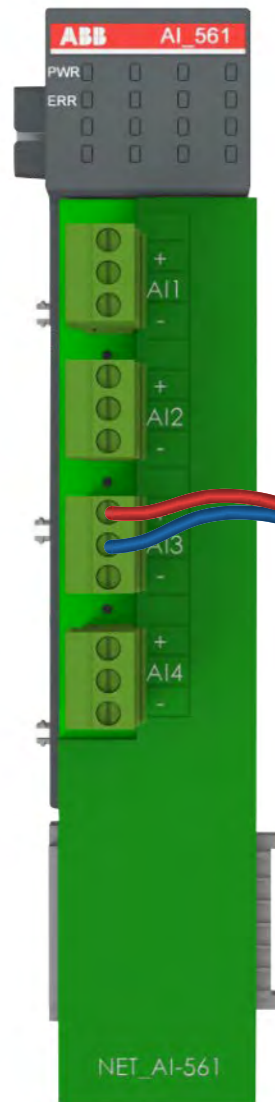

8 analog inputs

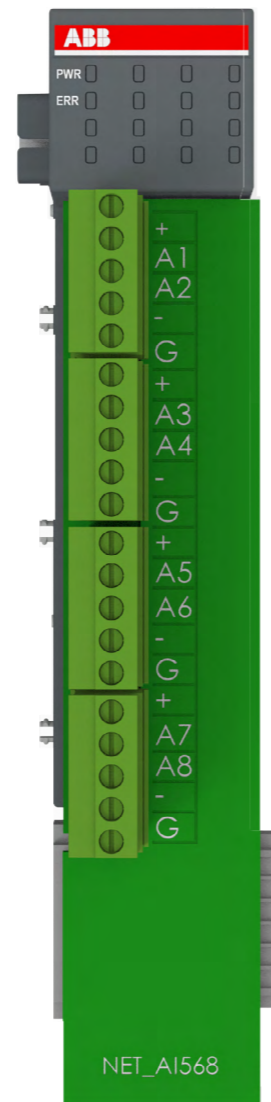

Analog PS

## 4.6 Connect to remote units

### / Connection of weather station – RS232

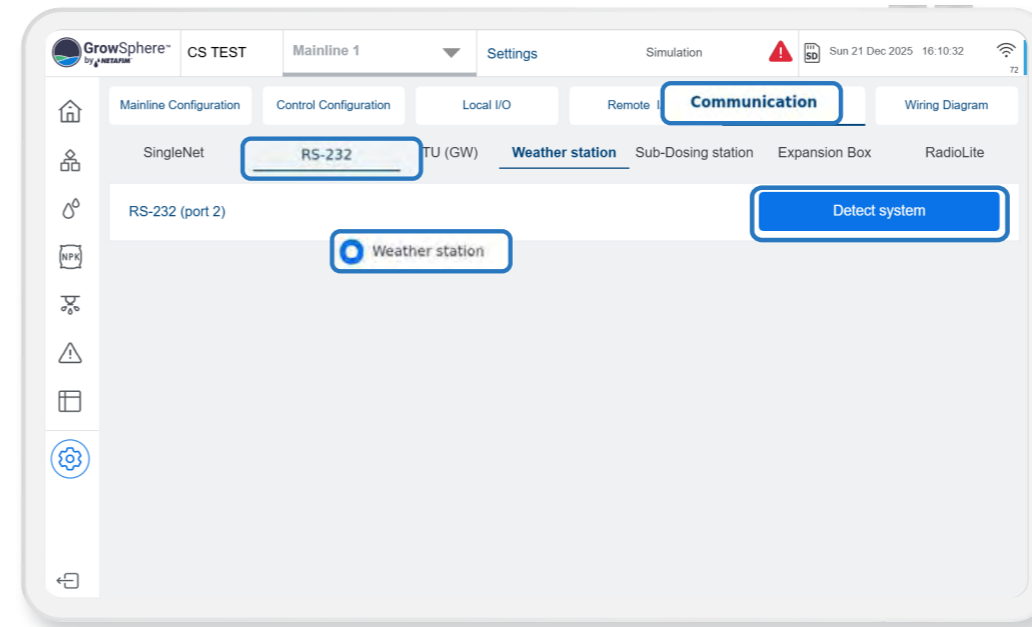

For Remote-units instructions - Please see the Appendix

### / RS232 Module

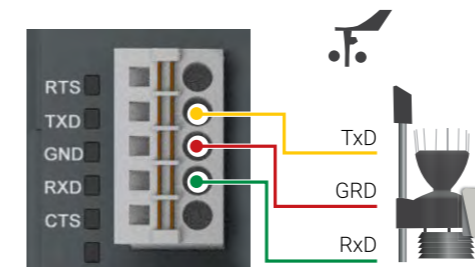

State LEDs

Signal	Color	State	Description
TxD	Yellow	ON (blinking)	Transmitting
RxD	Yellow	ON (blinking)	Receiving

Signal	Description
RTS	Request To Send DCE is ready to accept data from the DTE
TxD	Transmit Data (output)
GRD	Common Ground
RxD	Receive Data (input)
CTS	Clear To Send (input) DCE is ready to accept data from the DTE



## / Connect to RadioNet / SingleNet – Serial module RS485

1. Before starting this process, please ensure you have the latest version of PoleNet & Polenet2Max Apps.
2. In order to set up the Remote units, kindly get in touch with our Global support team via email at [cmt.support@netafim.com](mailto:cmt.support@netafim.com)
3. Both RadioNet & SingleNet can be connected simultaneously

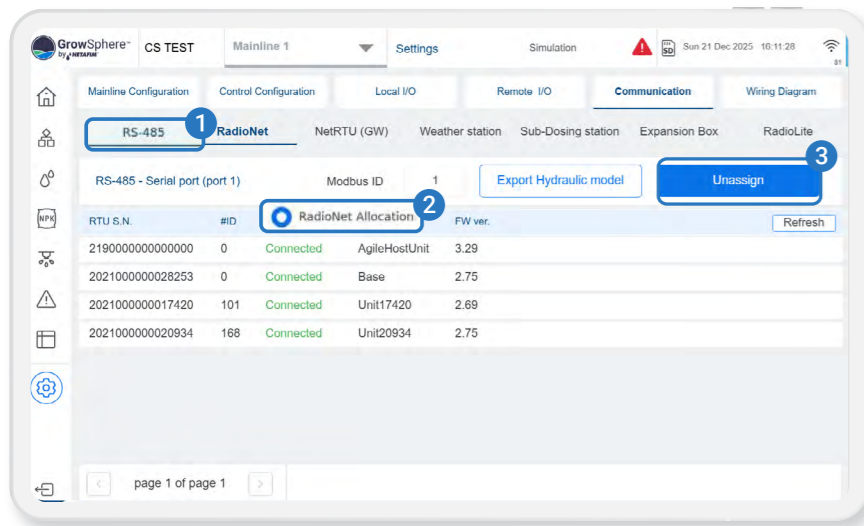

## / RS485 module

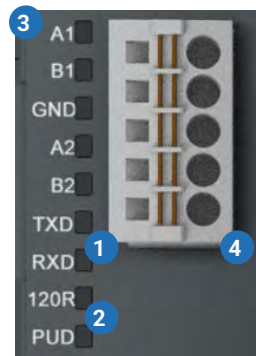

State LEDs

Signal	Color	State	Description
TxD	Yellow	ON (blinking)	Transmitting
RxD	Yellow	ON (blinking)	Receiving
120R	Yellow	ON	Bus termination
PUD	Yellow	ON	Pull-up / Pull-down

1. 2 LEDs for communication state display (TxD and R&D).
2. 2 LEDs for termination state display.
3. Allocation of signal name.
4. 5-pin terminal block for communication interface.

## / Wiring SingleNet host & GrowSphere™ MAX

GrowSphere™ Max

SingleNet Host

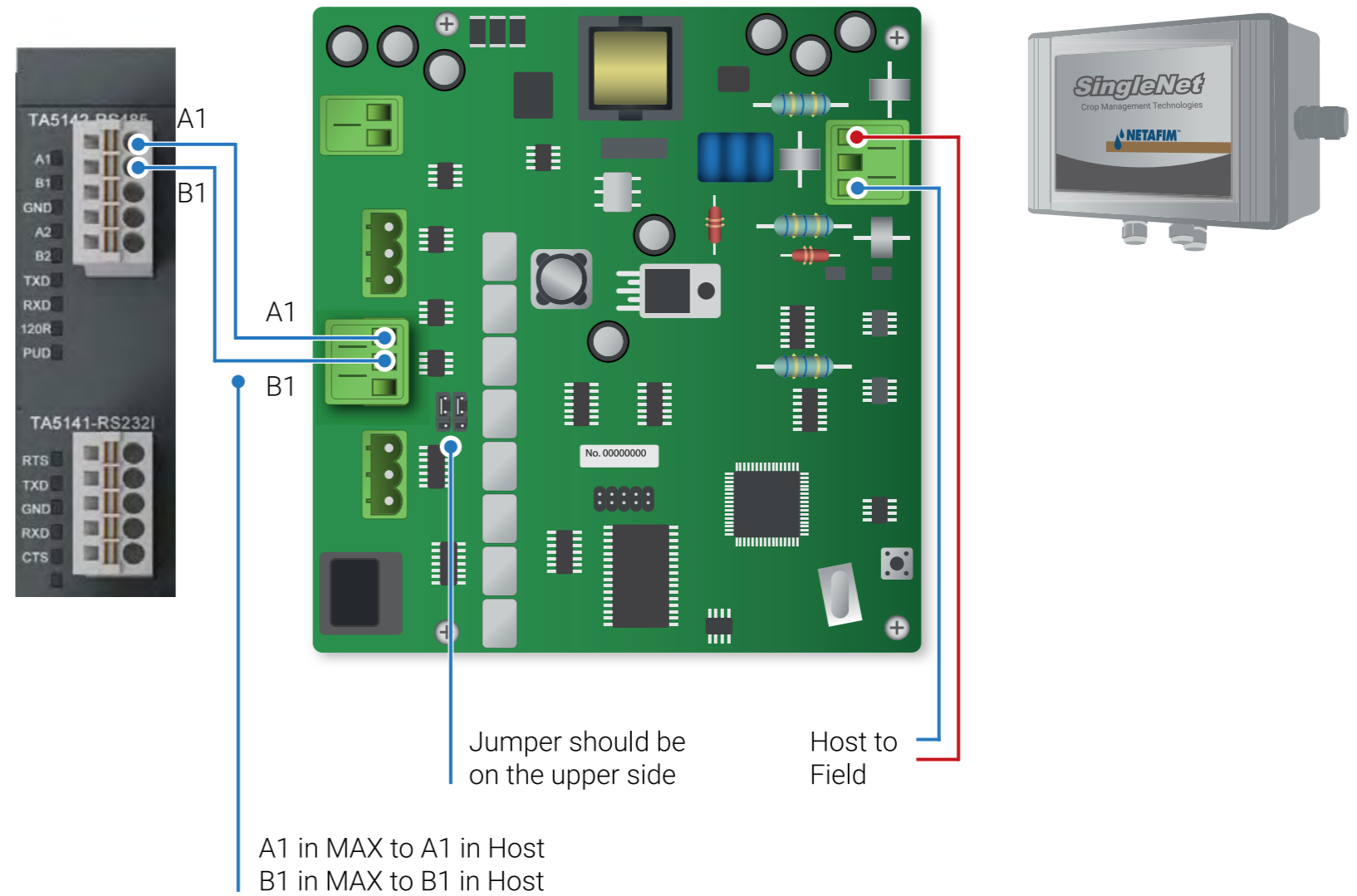

## / Wiring RadioNet host & GrowSphere™ MAX

GrowSphere™ Max

RadioNet Host

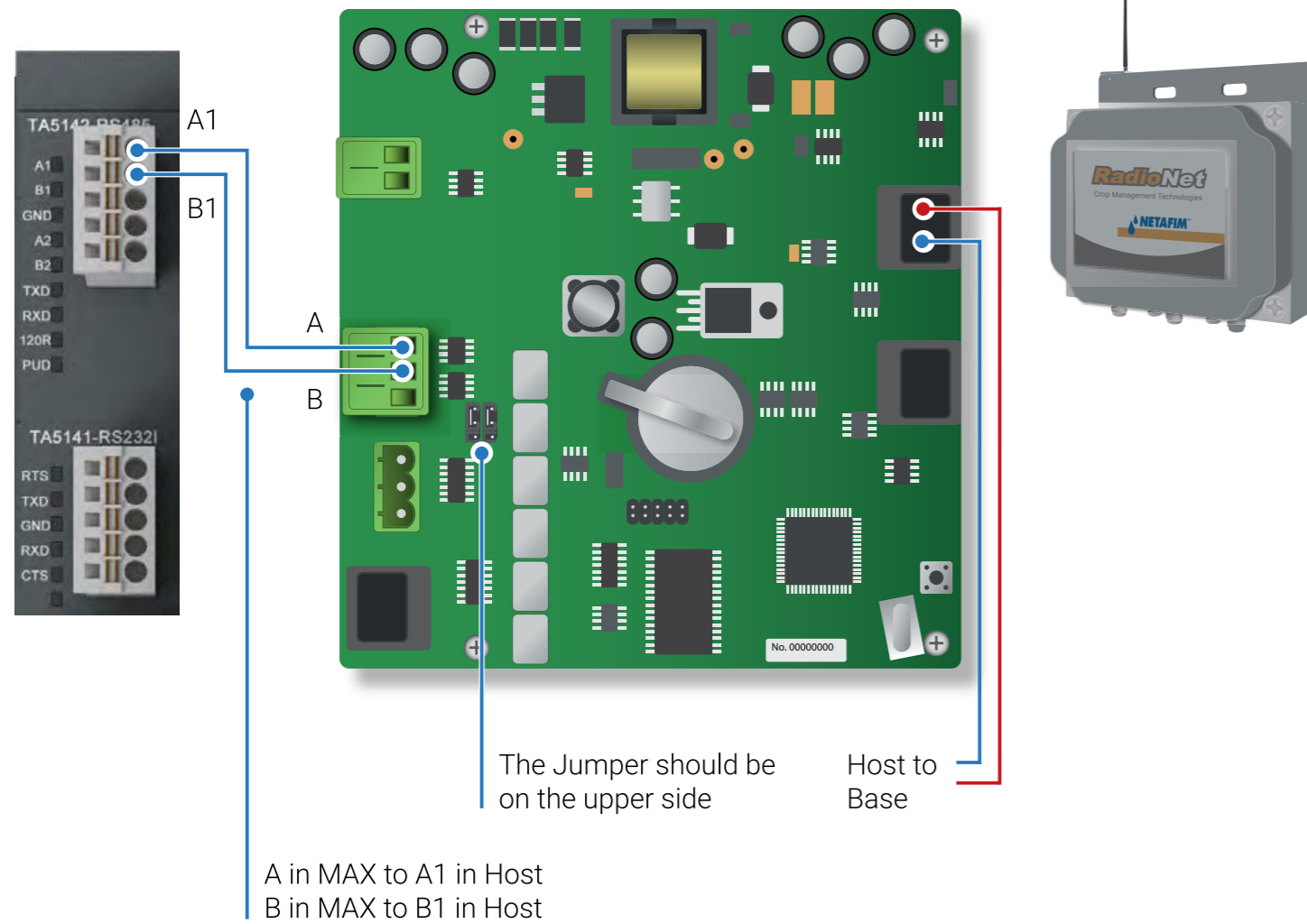

## 4.7 Dosing settings

### / Set dosing station configuration

1. Define the numbers of dosing channels and agitators and activate them
2. Select the connected devices that are part of the dosing station

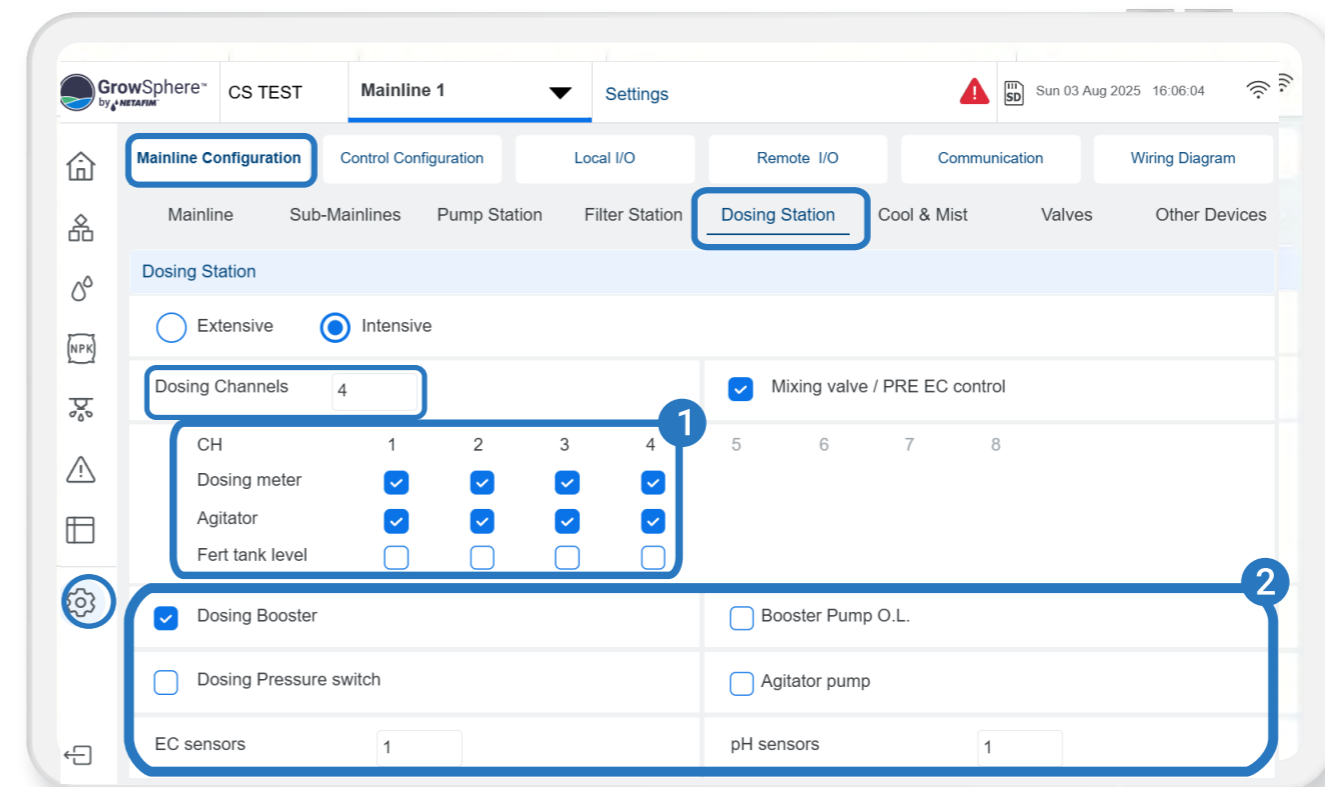

## / Define analog inputs

1. When you click on Assign, a list of devices that have been allocated will appear.
2. From there, you can choose the sensor you want to work with and set the input ranges, name, and offset for each sensor
3. To assign additional analog sensors, simply navigate between the pages

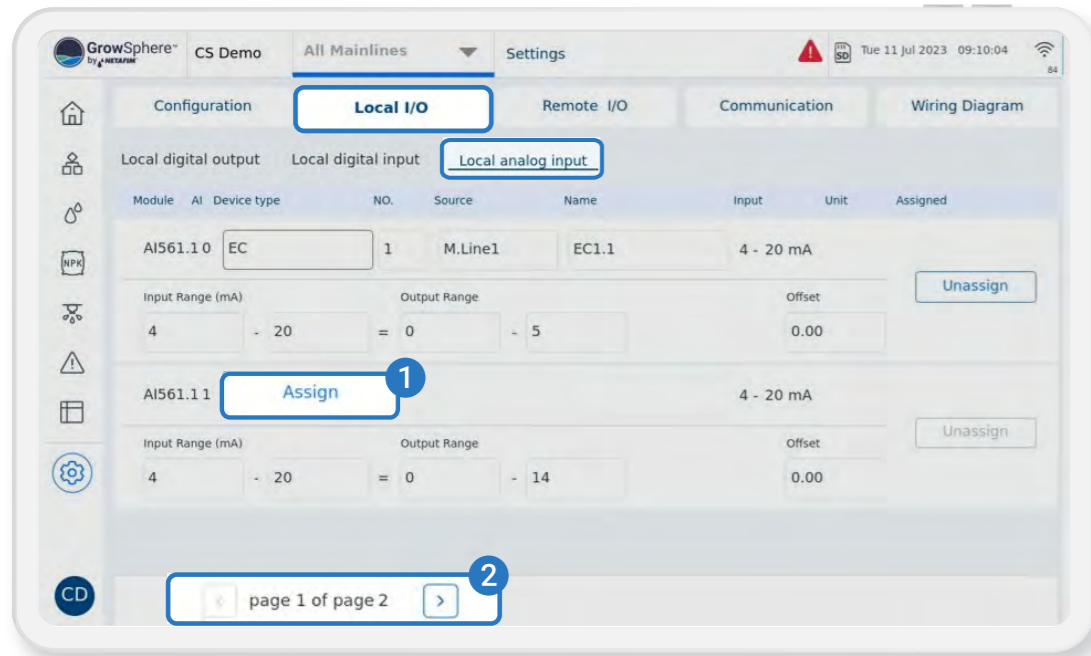

By clicking on Assign, the list below will be opened.  
The allocated devices are presented in the list

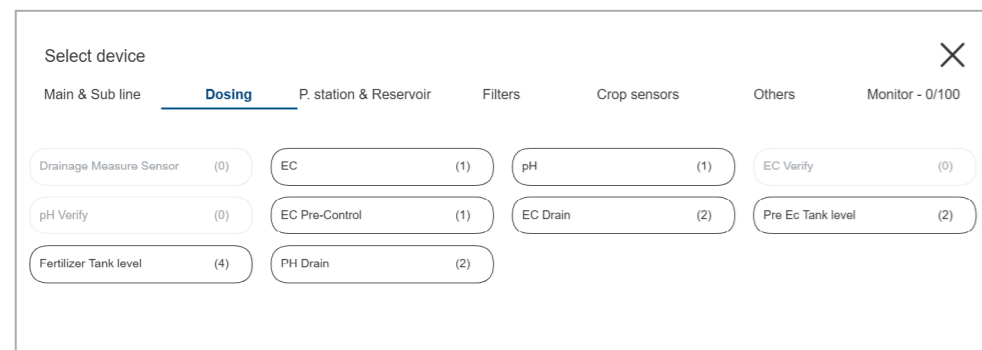

## / Set Dosing channels

1. Activate the connected channels.
2. Define the Type, Minimum and Nominal flow, Reaction, DM rate and deviations for each of the channels.

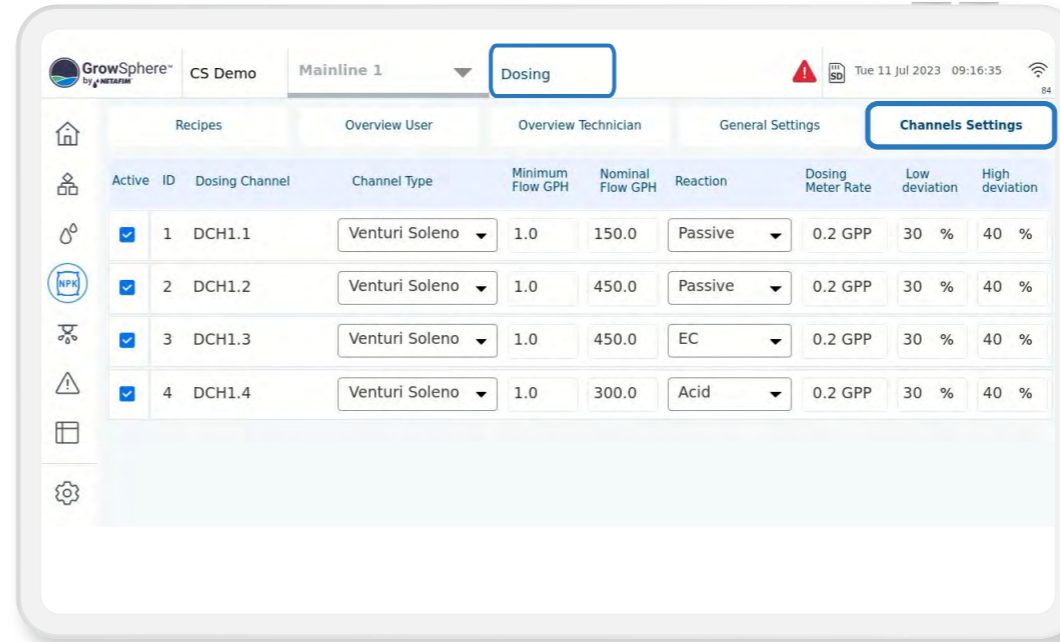

## / Set EC and pH reaction methods

1. Select "Intensive" only for Local Dosing Channel control & EC-pH control is required.
2. Select "Extensive" only when Dosing Channels are operated by Remote Units. In this case Only Bulk or Spread methods are available.

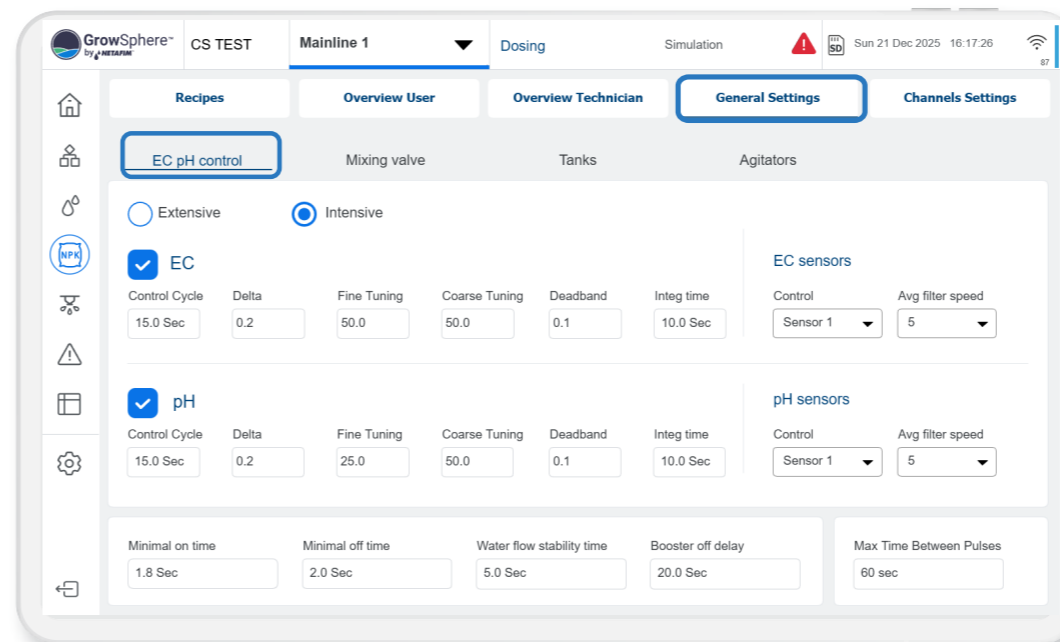

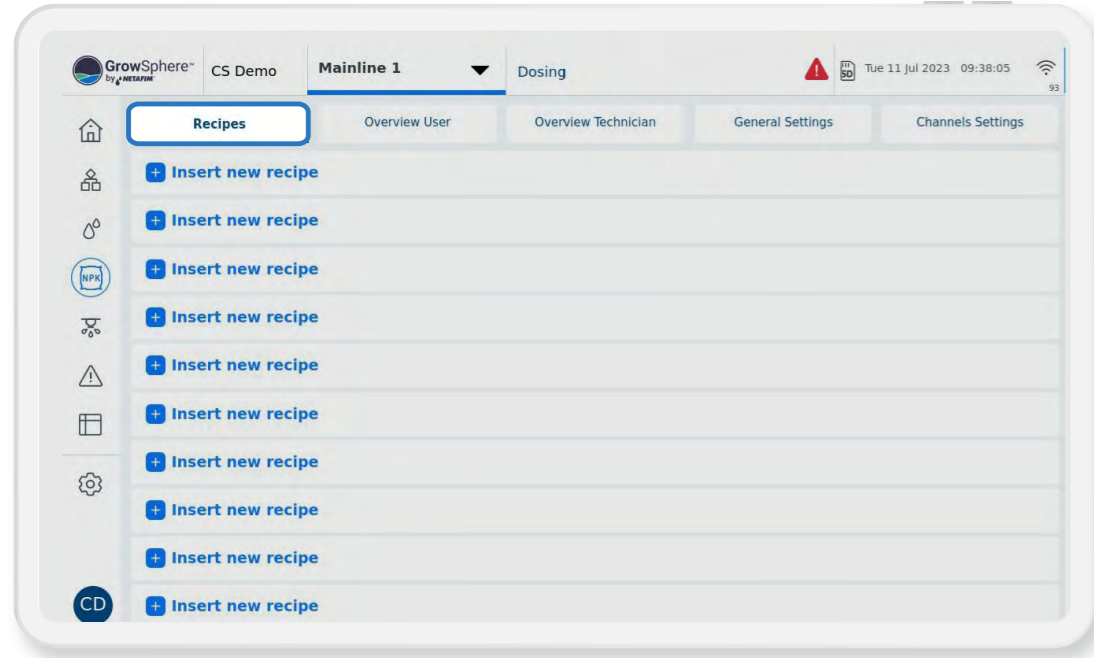

### / Create new dosing recipe

Click on the Insert new recipe to create a new dosing program.

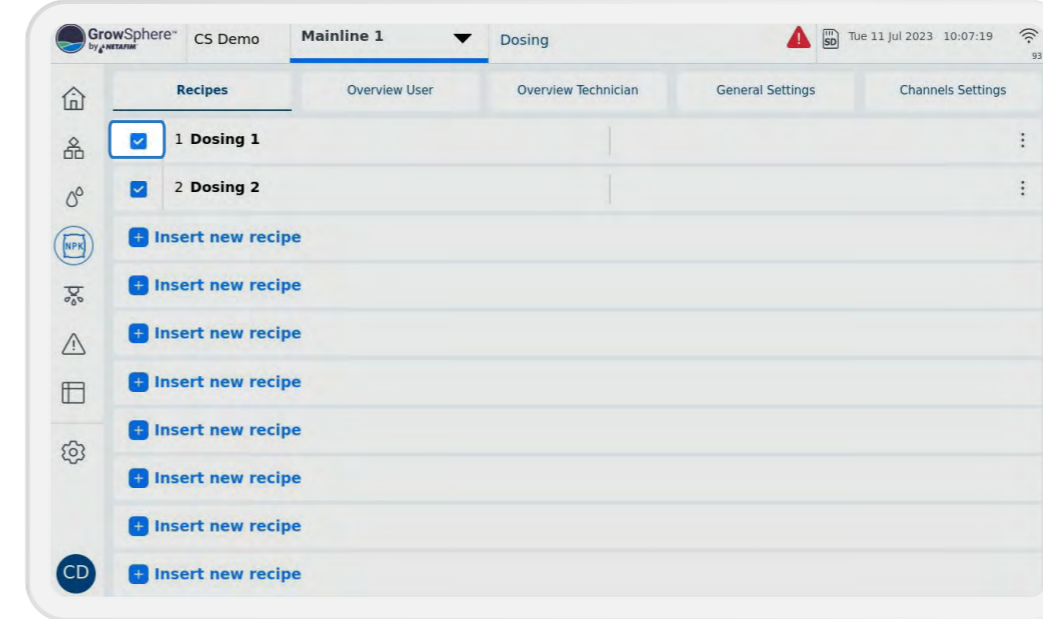

### / Activate the recipe

Activate the recipe, and repeat this action for other dosing recipes as required.

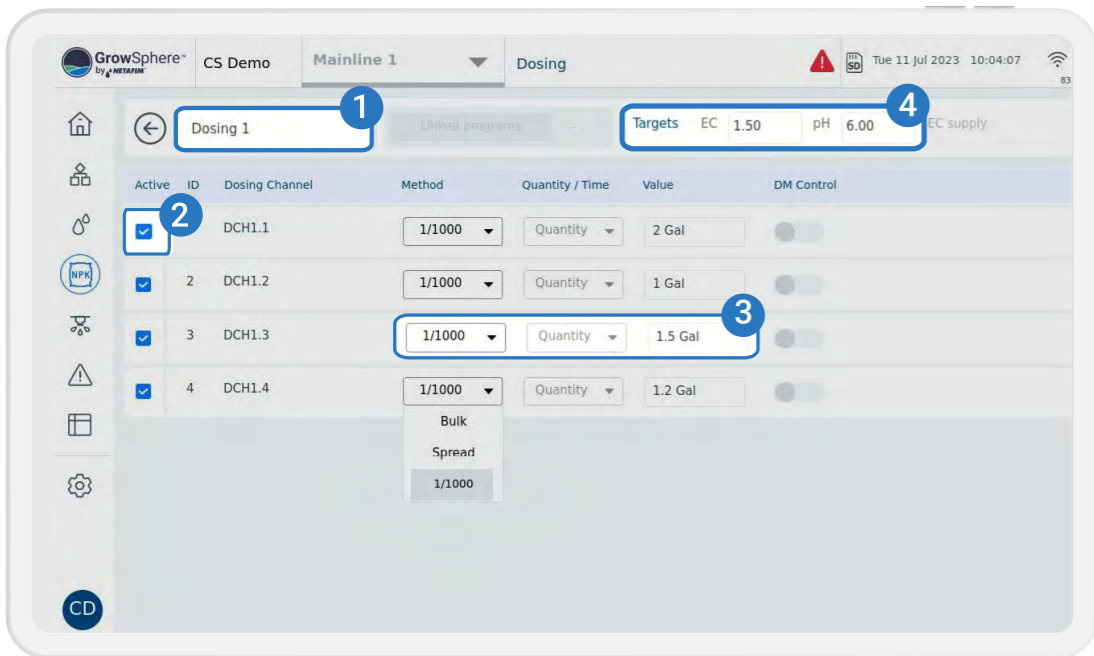

### / Define the dosing recipe' channels

1. Name the recipe
2. Activate the recipe's dosing channels.
3. Select the methods and quantities and the Value for each channel. DM Control can be activated if required.
4. Set the target EC & PH Can be set only for 1/1000 Dosing Method.



## / Connection of DO572 module

- 8 triac outputs – 24 VAC
- 'C' – Shared common
- Output current per channel = 2 A
- 2A Thermal Fuse on each channel. Not removable
- Indication of output signals – 1 yellow LED per channel
- The LED is on when output signal is high

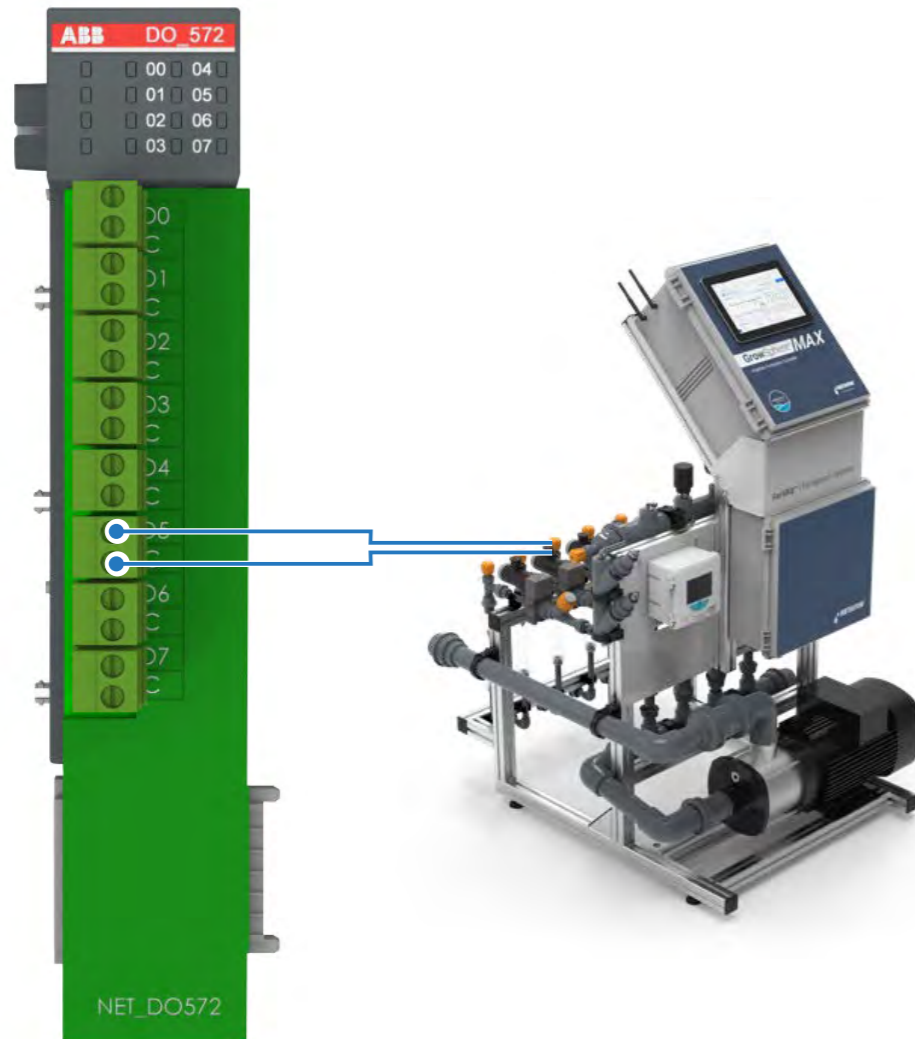

## / Connection of analog inputs module EC, pH - A1561

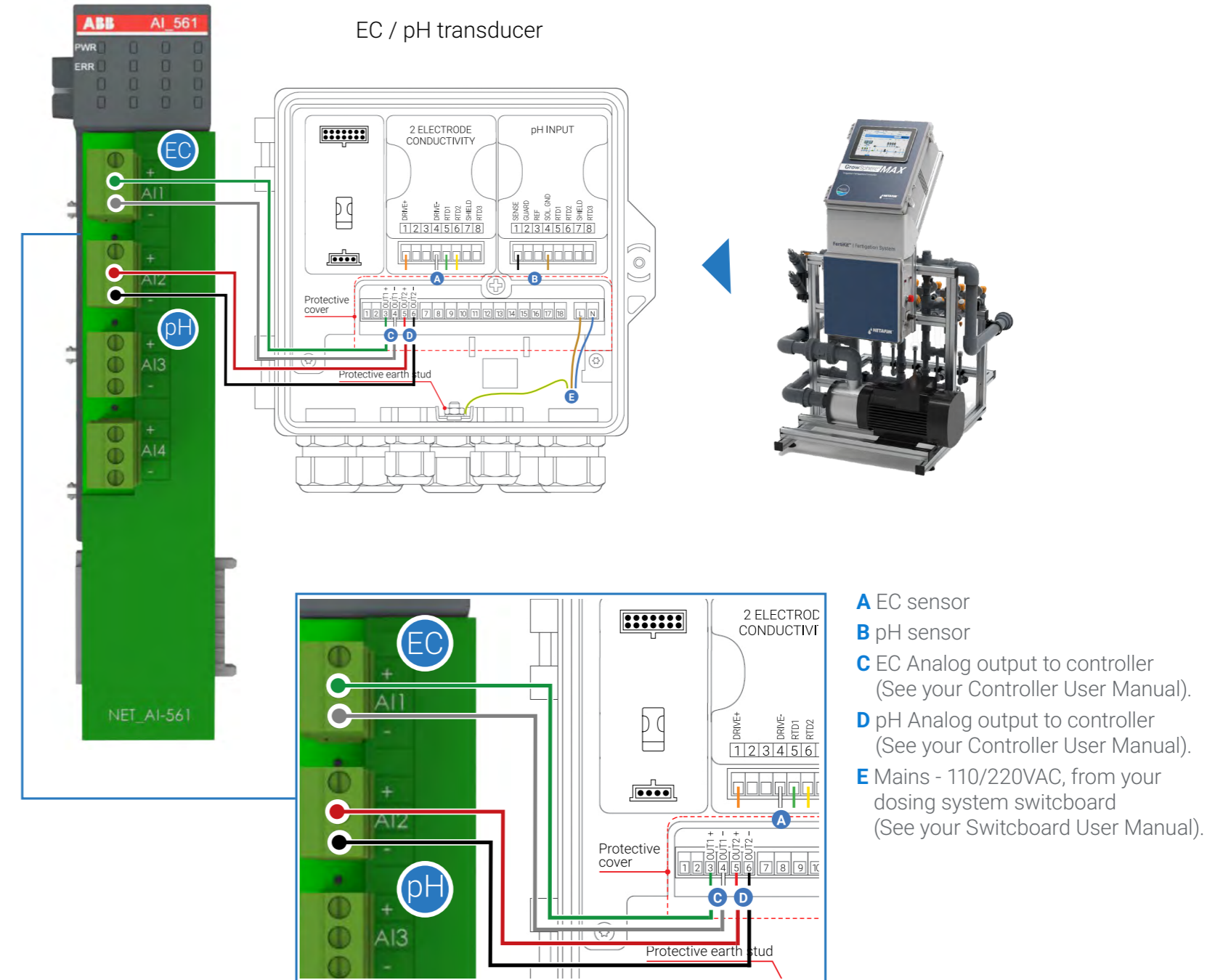

## 4.8 Create irrigation program

### / Create new irrigation program

Click on Insert new program

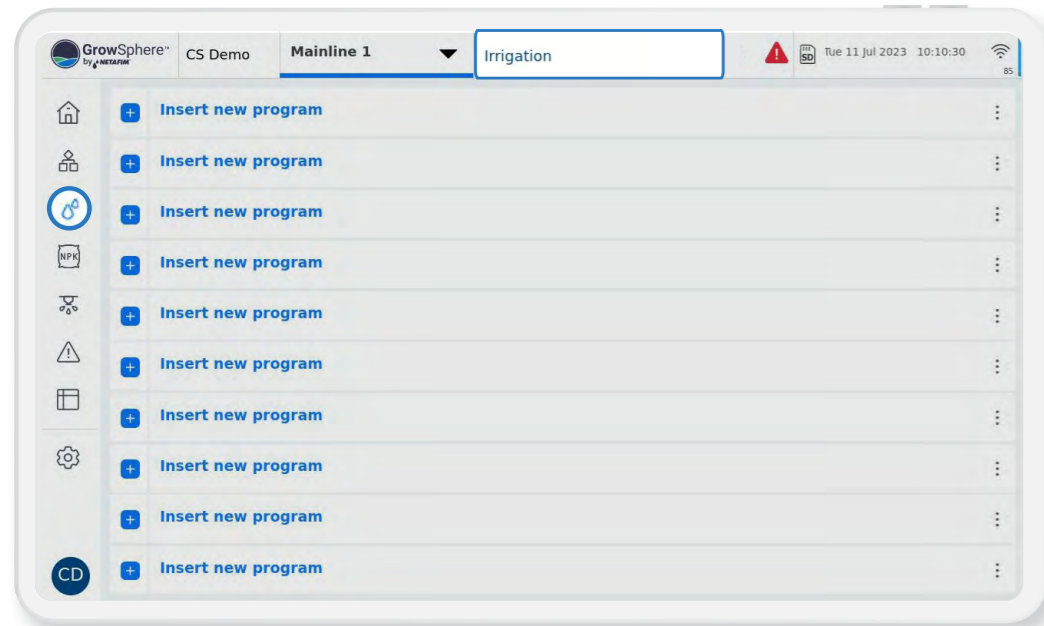

### / Set irrigation program

1. Name the irrigation program.
2. Specify the type of irrigation program, its priority, and the units to be used.
3. Click on Shifts to create shifts (see next page)
4. Click Dosing to select the Dosing program.
5. Set start times and triggers for irrigation.
6. Choose the days for irrigation and specify whether you want to use water only (indicated by blue) or dosing plus irrigation (indicated by green) for each selected day
7. Provide definitions for water before and after for a shift or program.

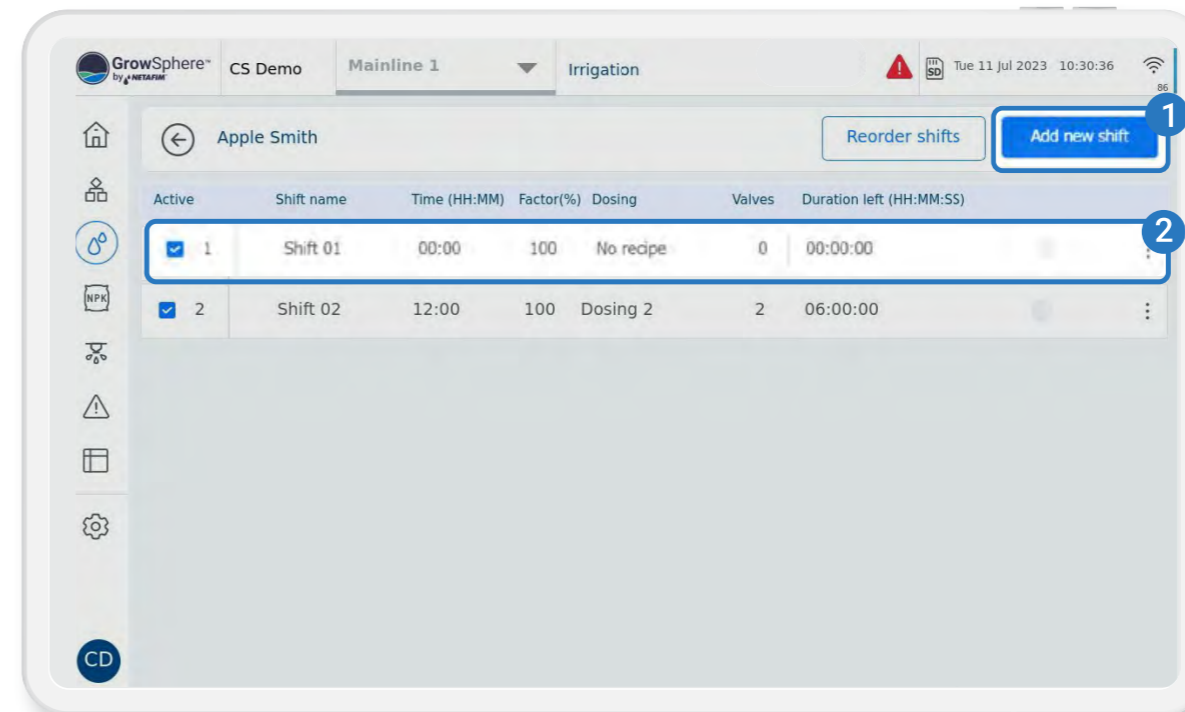
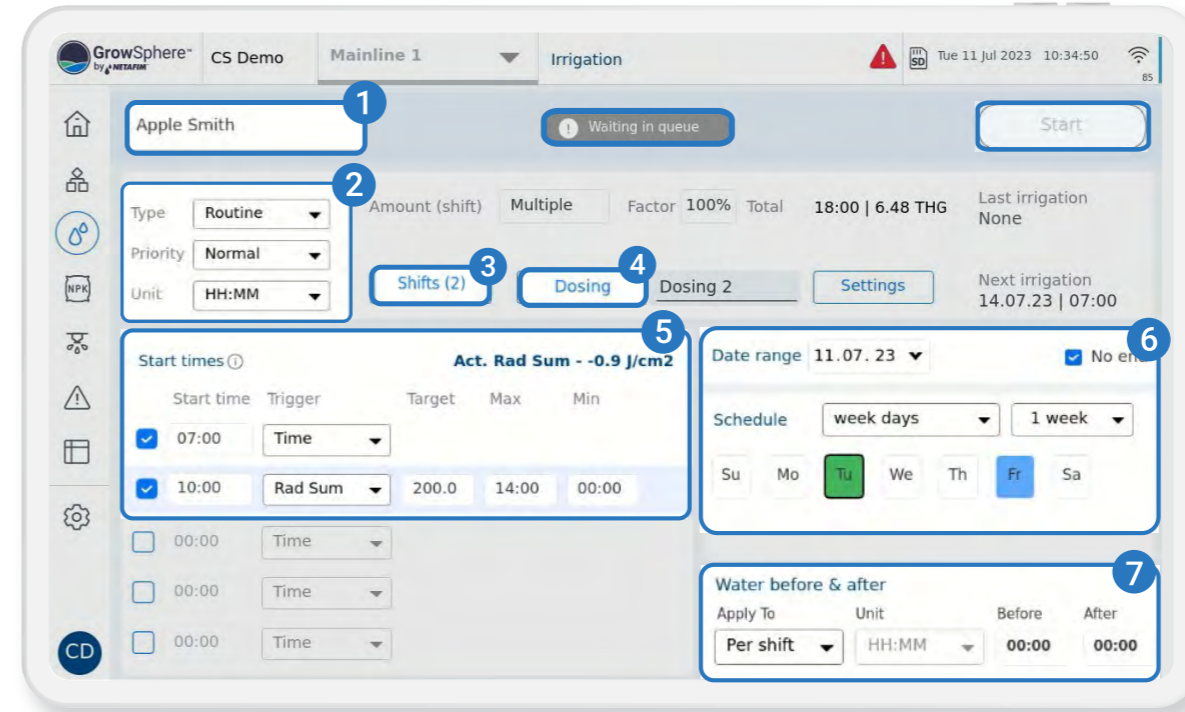

### / Edit and/or add a new shift

1. Click to add a new Shift
2. Click to edit an existing Shift



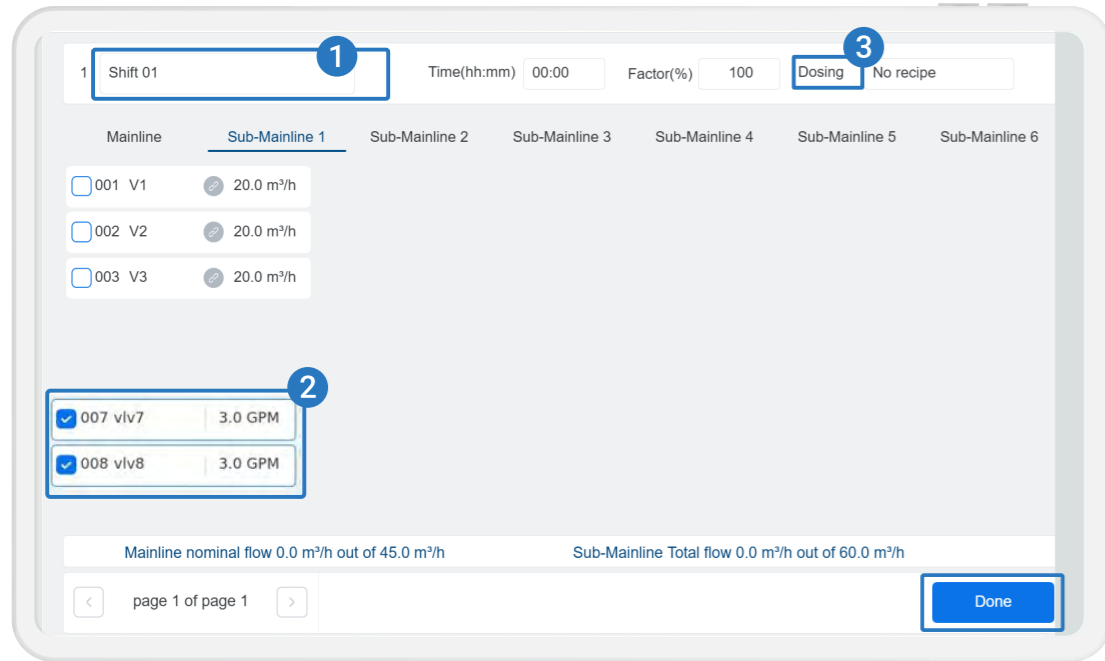

### / Edit and/or add irrigation shifts

To assign valves to a shift, follow these three steps:

1. Give the shift a name
2. Choose the valves you want to assign to the shift from any sub mainline
3. Assign the shift to a dosing recipe
4. Assign "Run Time" for shift here

- Mention Max. No. of Valves in a shift : 32
- Mention Max. No. of shifts in a program : 32

### / Assign dosing recipe to irrigation program

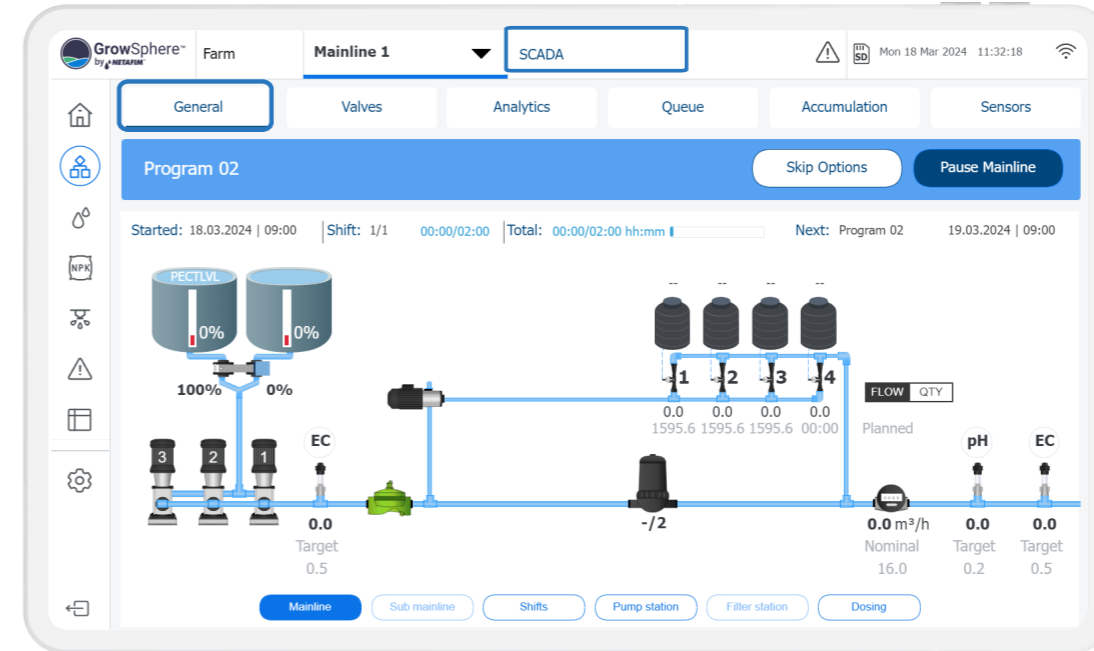
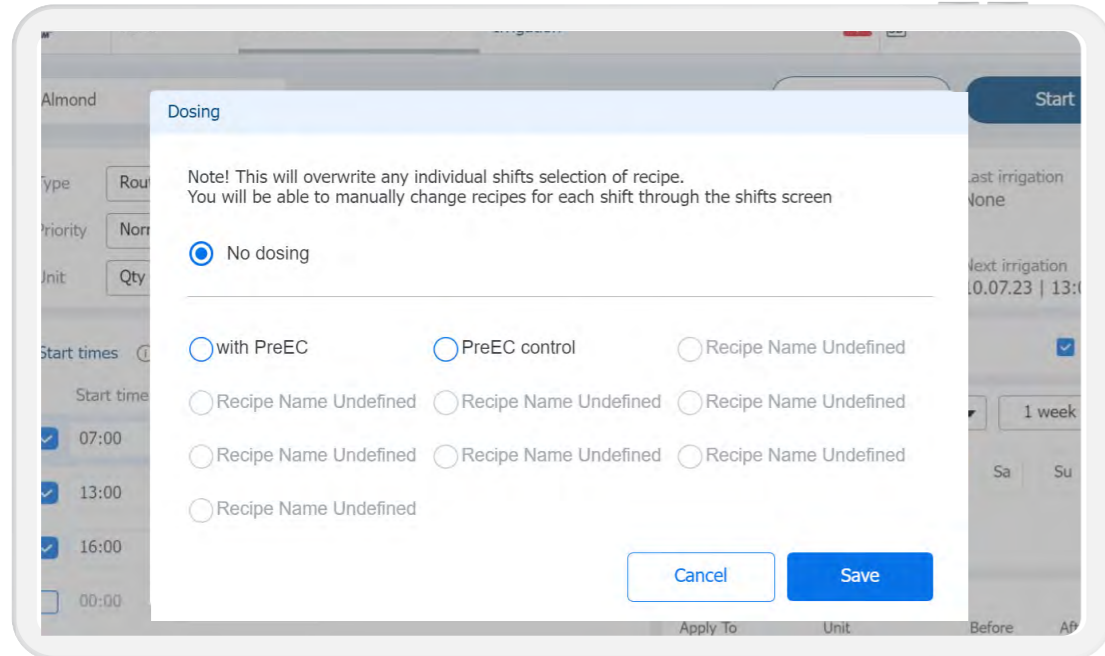

### / Quick view of your irrigation operation status



## 4. Introduction

This chapter introduces the irrigation and fertigation controller and includes:

**1/** GrowSphere™ MAX  
Overview

**5/** Controller Sticker

**2/** Configurations

**6/** EC/pH Unit

**3/** Summary of GrowSphere™  
MAX main features

**7/** Screen and  
Visualization

**4/** List of Connected  
devices

**8/** Environmental  
Conditions



## 4.1 GrowSphere™ MAX Overview - Architecture

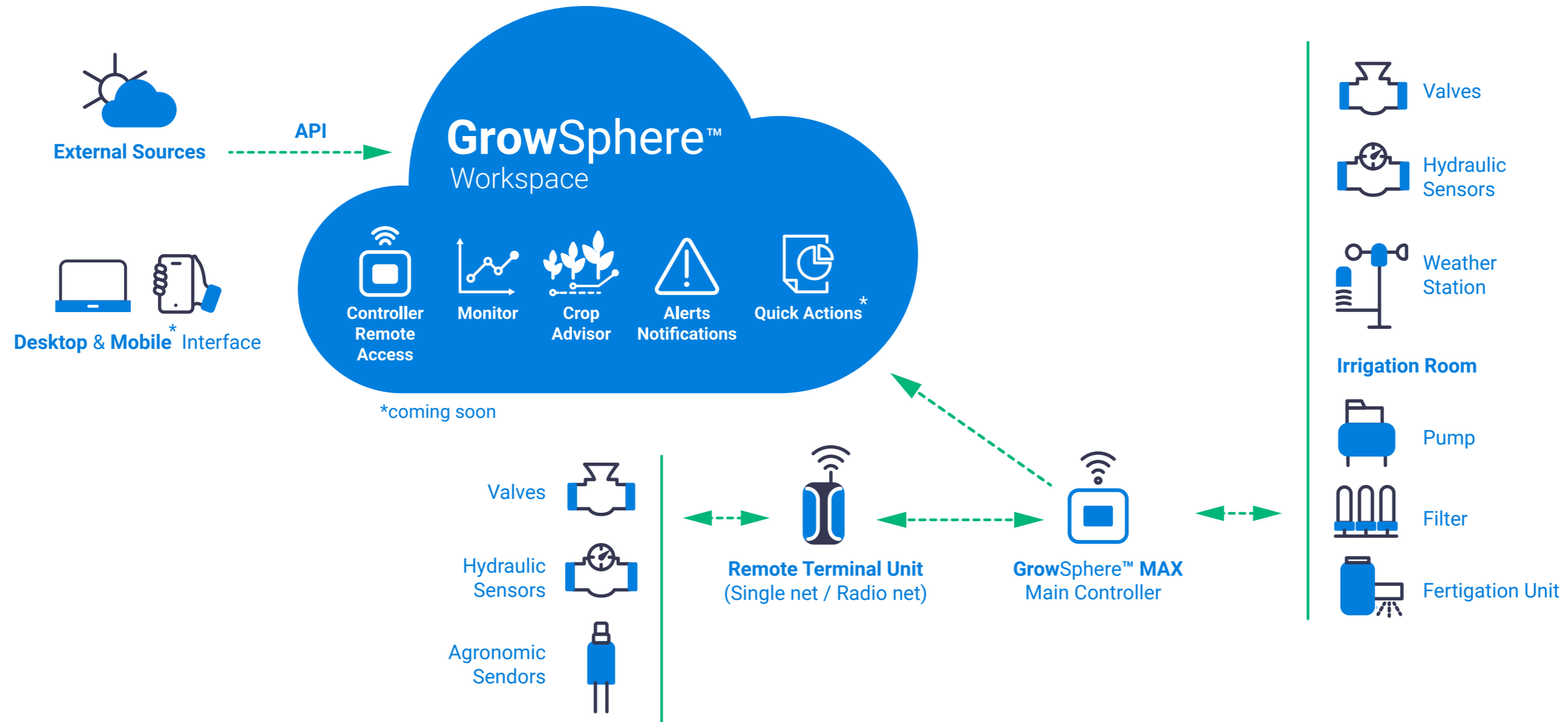

## 4.2 Configurations

**GrowSphere™ MAX** irrigation controllers is designed to cater to the diverse needs of growers, providing maximum adaptability and flexibility across indoor and outdoor agricultural settings. With four different configurations, a versatile range of controllers empowers agricultural endeavors to achieve optimal performance.



### GrowSphere™ MAX with Screen

**GrowSphere™ MAX (Touch Screen):** This controller comes with a user-friendly 10.1-inch touch screen interface and 6 digital outputs and 12 digital inputs by default, that make it easy to operate in agricultural environments. It can be operated on both 110V and 220V power supplies.



### GrowSphere™ MAX Core model

**GrowSphere™ MAX Core (No Display):** The controller provides reliable functionality without a display and without any add ons. It is suitable for indoor and outdoor cultivation and ensures precise control without compromising simplicity. This controller can operate on both 110V and 220V power supplies. To upgrade the controller for Remote access, RadioNet/SingleNet and weather station support. devices need to be purchased separately.



### GrowSphere™ MAX with Double Door

**GrowSphere™ MAX Double Door:** Designed for outdoor agricultural installations, the double-door design ensures easy accessibility, making it suitable for outdoor farming settings. This 110V or 220V controller maintains 6 Digital Outputs and 12 Digital Inputs by default.



### GrowSphere™ MAX with Fertikit

**Fertikit™ 5G with GrowSphere™ MAX:** This integration is designed specifically for open field nutrigation application. It combines the specialized capabilities of **Fertikit™ 5G** with the robust functionality of **GrowSphere™ MAX**. The controller comes with 14 digital outputs and 12 digital inputs by default, offering precise and efficient nutrient management tailored explicitly for precise dosing management. This optimized crop growth and yield.



## 4.3 Summary of GrowSphere™ MAX's main features

The Controller includes the following major components:

	Per Main Line	Total
Main Line	1	4
Main Valve	1	4
Sub mainline per mainline	6	24
Main Water Meter	1	4
Pumps	3	12
Filter Station	1	4
External filter (flushing control + indication)	32	128
Dosing Stations	1	4
Dosing Channel (venturies)	8	32*
Valves	160	256
Reservoir per controller	--	1
Well/pumps per reservoir	--	6
DMS	8	32
Central Pump station	For all ML up to 8 pumps	
Electricity meter	--	4 per controller

	Per Main Line	Total
Cooling valve	32	128
Misting valve	32	128
Cooling/Misting valve	16	64

	Per Sub-main Line	Total
Water Meter	1	6
Main valve	1	6
Pressure sensor	1	6

Irrigation Programs	10
Shifts per program	20
Valves Per Shift	32
Dosing Recipes	10

\*Subject to I/O modules configuration and a maximum capacity of 6 modules per controller and up to 4 expansion boxes per controller, each with additional PLC and 6 IO modules

Capacity is including Remote Units

\*\*Above 8 dosing channels it is required to check the controller power capacity use and if needed more than 100VAT, it is required to use an external transformer to increase capacity



## 4.4 List of Connected Devices and Fertigation Functionalities

The table below demonstrates the options for connecting the **GrowSphere™ MAX** to a different device:

### MAX

	Digital output	Davis WS	Analog sensors	Serial soil sensors	Digital hydraulic sensors	EC/pH sensors	Filter flushing and indication	Dosing by bulk/spread	Proportional dosing	Dosing with EC / pH control	Pre EC control
MAX	✓	✓	4-20mA	—	✓	✓	✓	✓	✓	✓	✓

### Remote Units

	Digital output	Davis WS	Analog sensors	Serial soil sensors	Digital hydraulic sensors	EC/pH sensors	Filter flushing and indication	Dosing by bulk/spread	Proportional dosing	Dosing with EC / pH control
RadioNet	✓	—	✓	✓	✓	—	—	✓	—	—
SingleNet	✓	—	—	—	✓	—	—	✓	—	—



## 4.5 Controller Sticker

### 1. Product description

### 2. Netafim SKU

### 3. Hardware revision

### 4. Ordinal production number

4.1 Production year

4.2 Production week

### 5. Identification number (use for Add device)

### 6. Modem SSID (Wi-Fi address)

### 7. Wi-Fi Password (to connect through Wi-Fi)

### 8. Modem IMEI



### 9. Wi-Fi username and password QR code

### 10. PLC S/N – Scan for add device

# GrowSphere™



**1** GS-MAX-DISP-220V-22DO-12DI-4AI-8TRC

 **3** 

**2** SKU: 74702-000062      REV D4



**4** S/N: 4.1 10-MAX-2324-1234 4.2

<b>5</b> PLC S/N:	A1PM5052-R-ETHL2212345678
<b>6</b> SSID:	RUT240_6283
<b>7</b> WIFI PW:	g9Z1KrAz
<b>8</b> IMEI:	 864677061890703

**9** WIFI QR CODE



**10** INSTALLATION CODE







## Relay output – 16 OUT

- 16 Outputs - Relay
- Shared Common
- Kickback protection
- 24 VAC 80 VA

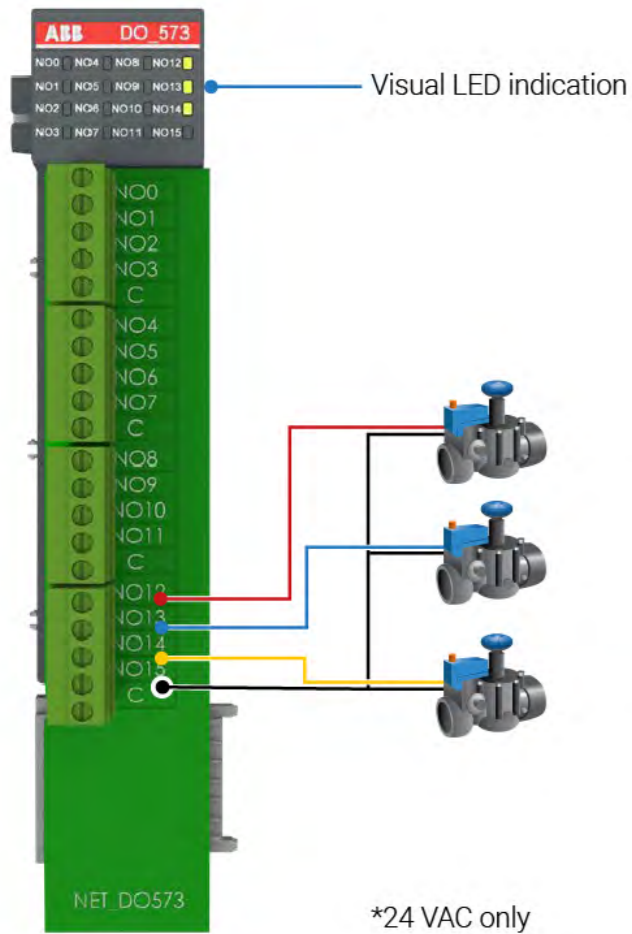

## Dosing Module – Triac

- 8 Outputs - TRIAC
- Shared Common-for each valve
- Over Current Protection
- 24 VAC @ 80 VA

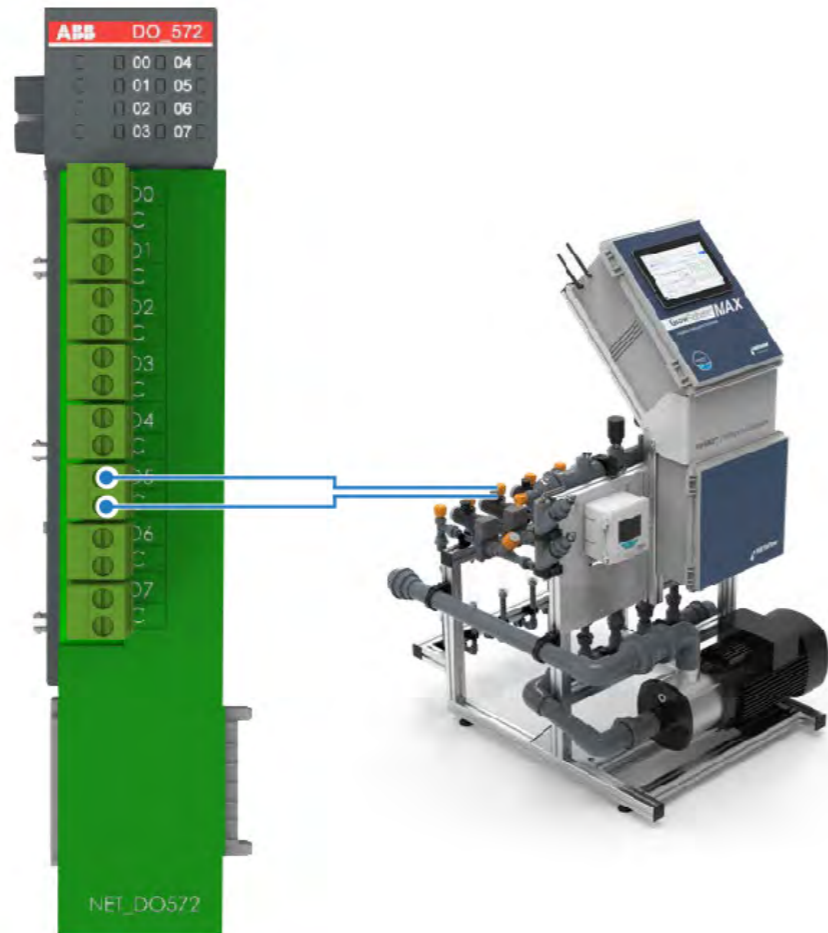

## Digital Inputs Module

- 16 Inputs
- Dry/ Active Contact
- Feed voltage - 24 DC

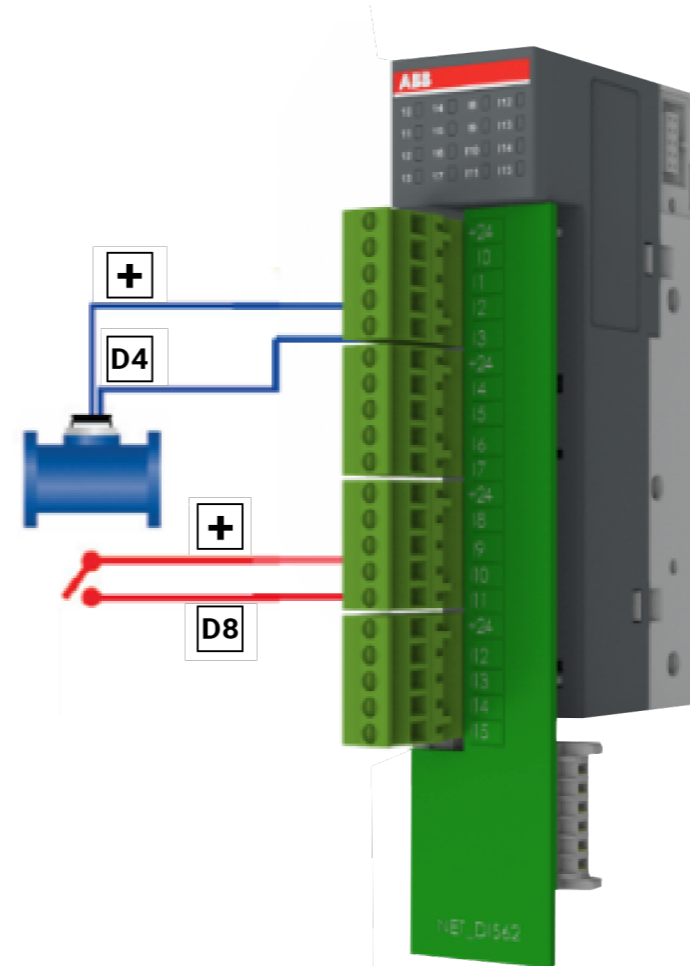

## Analog Inputs Module

- 4/8 Analog Inputs
- 0-20 mA
- Feed Voltage 24 DC

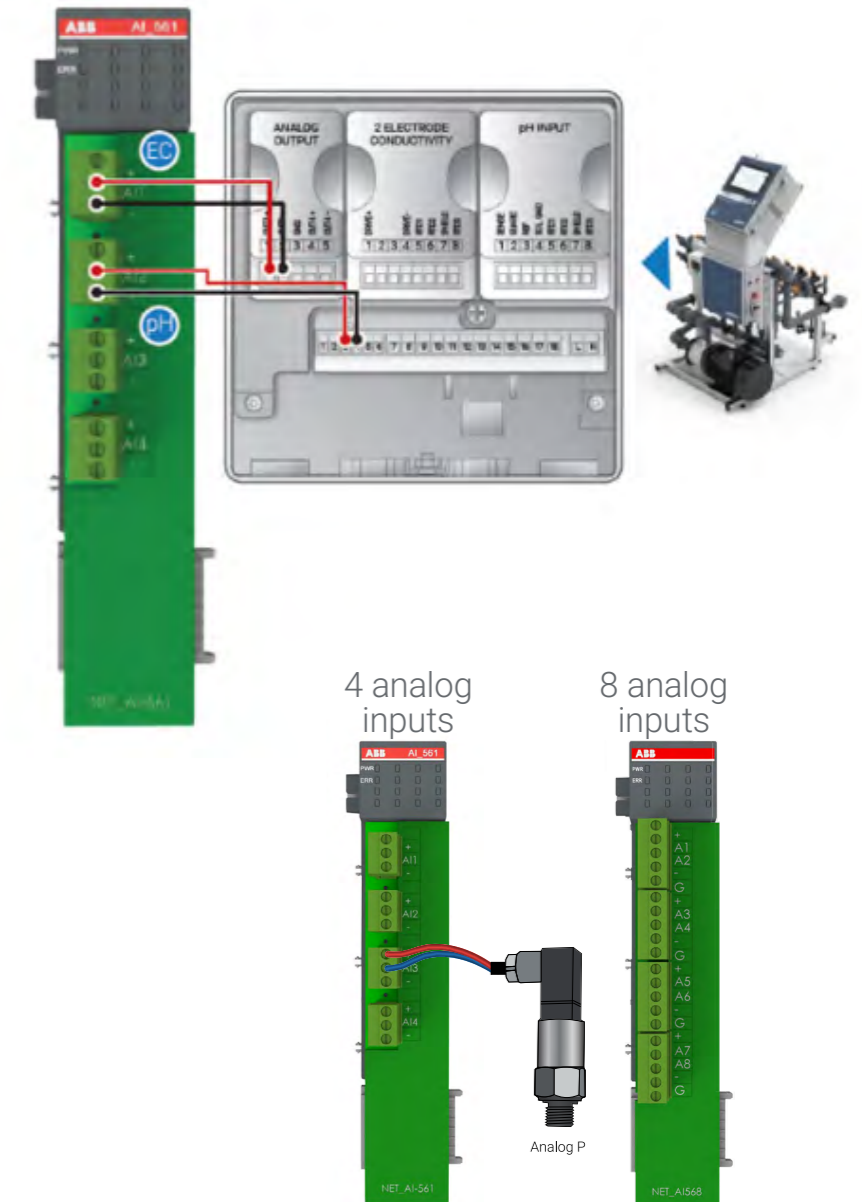

## 4.6 EC & pH connection

Only the connections relevant to EC and pH sensing configuration are described. For more details, please go to the ABB AWT420 EC pH transmitter manual

### WARNING

The main board connections are located under the protective cover. The transmitter AC version runs high current. To avoid electrocution make sure you put the protective cover back in place after wiring the transmitter.

### ABB EC/pH Transducer

- A** EC sensor
- B** pH sensor
- C** EC Analog output to controller (See your EC/pH module User Manual).
- D** pH Analog output to controller (See your EC/pH module User Manual).
- E** Common
- F** Mains - 110/220VAC, from your dosing system switchboard (See your Switchboard User Manual).

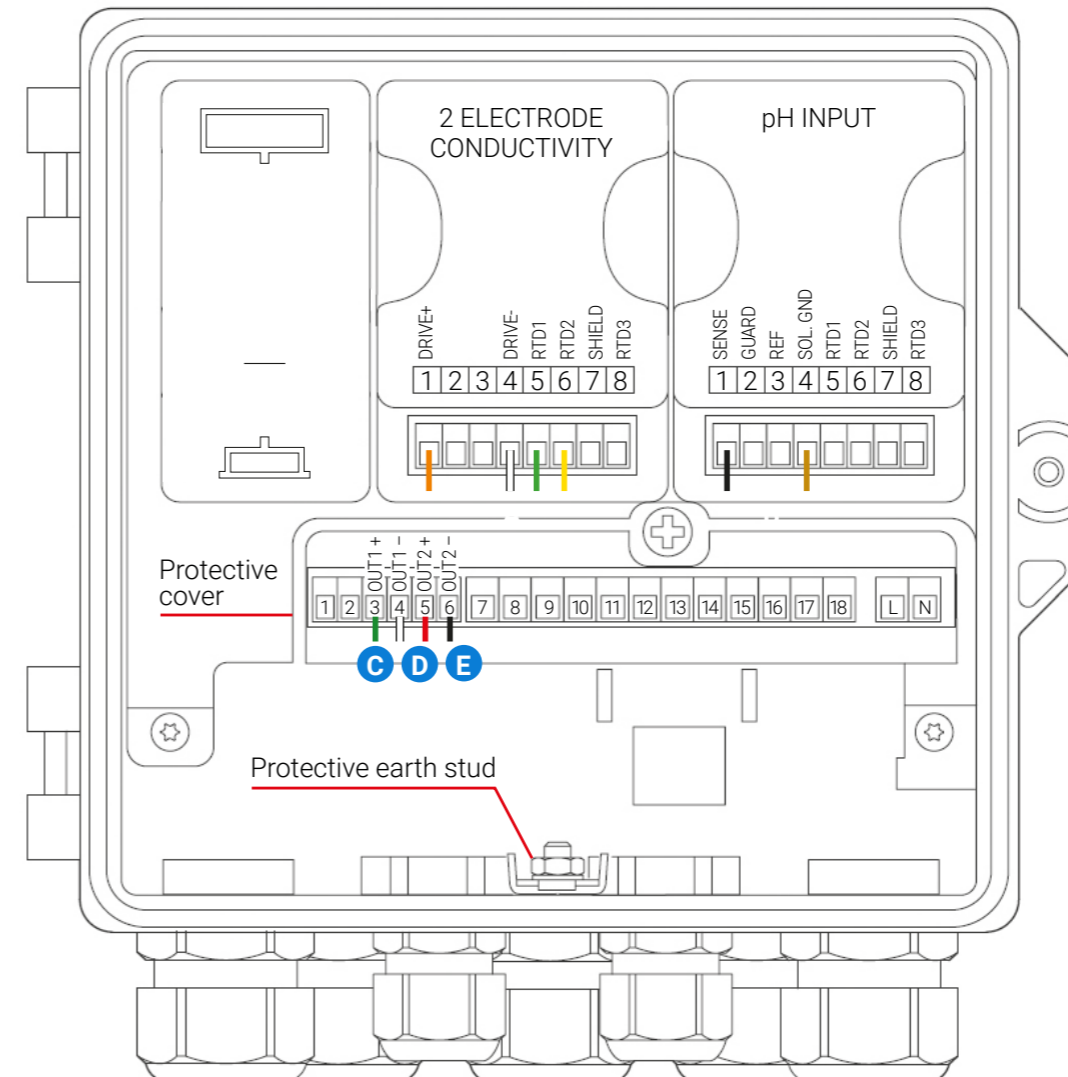

## 4.7 Screen and Visualization

- **Color touch 10.1" LCD screen** (in the **GrowSphere™ MAX** screen configuration).
- **Built-in multilingual software.** Switch languages with a single keystroke. To check the supported languages go to the app settings --> preferences.
- **Real-time operational status screen (SCADA).**



## 4.8 Environmental conditions



### The GrowSphere™ MAX should be:

- Placed in a roofed building protected from direct sunlight
- Kept at an ambient temperature between 10°C and 50°C (50°F and 104°F)
- Kept at a maximum relative air humidity of 90%
- Properly ventilated
- Protected from dust
- Protected from splashes or direct spraying with water or chemicals

### Communication

Wi-Fi	IEEE 802.11b/g/n
Mobile Module	4G (LTE) – Cat 4 up to 150 Mbps

Parameters	MAX Expansion Box	Dosing Substation
Communication protocol	TCP/IP	Modbus TCP
Maximum latency	300 ms	500 ms
Maximum data rate per station	100 kB/s	100 kB/s
Maximum cable length per segment	100BASE-TX (copper) - 100 m	
Cable type	Minimum Cat5e	
Power over Ethernet	No	
Connector type	RJ45	RJ45
Automatic IP allocation	Yes	Yes



## Specifications

Power supply	Mains Power 110/220 VAC, 50/60 Hz	
Input current	0.8A /220VAC 1.6A /110VAC	
Touch Screen	Optional	
Output 24VAC	Max. total output current (A/VA)	4A/100VA
	Max. output current per one line (A)	2A
Output 24VDC	Max. total output current (A/W) 2.5A/60W Max. output current per one line(A)	2.5A/60W
	Max. total output current (A/W) 2.5A/60W Max. output current per one line(A)	250 mA

Operation Temperature	0-50 °C
Operation Humidity	20-90 %
Storage Temperature	-10-70 °C
Storage Humidity	20-95 %
Max. operational altitude (m)	2000
IP Rating	IP65



## 5. Installation

This chapter reviews installing the controller and includes:

**1/** Mounting GrowSphere™

**5/** Connecting Dosing Outputs

**2/** Connecting to the CPU

**6/** Connecting Digital Outputs

**3/** Connecting Expansion Box

**7/** Connecting Analog Inputs

**4/** Connecting Digital Inputs

**8/** Connecting EC/ pH Units

**9/** Connecting Energy Meter



## 5.1 Mounting GrowSphere™

### 5.1.1 Mounting GrowSphere™ to Plate

Perform the following steps to mount the controller to a plate:

#### 1. Prepare a plate



#### 2. Drill holes

Drill four holes; one on each corner of the plate according to these measurements.

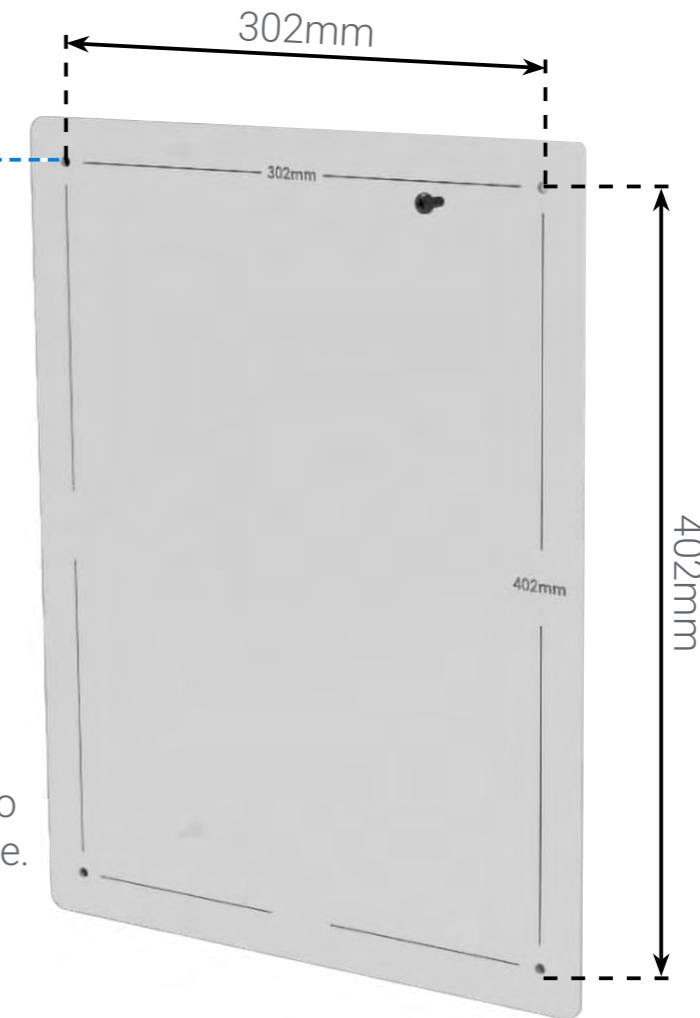

#### 3. Attach Controller to plate

Use the four screws supplied to attach the controller to the plate.

## 5.1.2 Mounting GrowSphere™ to wall

Perform the following steps to mount the controller to a wall:

### 1. Attach brackets

Attach one bracket to each corner of the controller using the screws supplied.

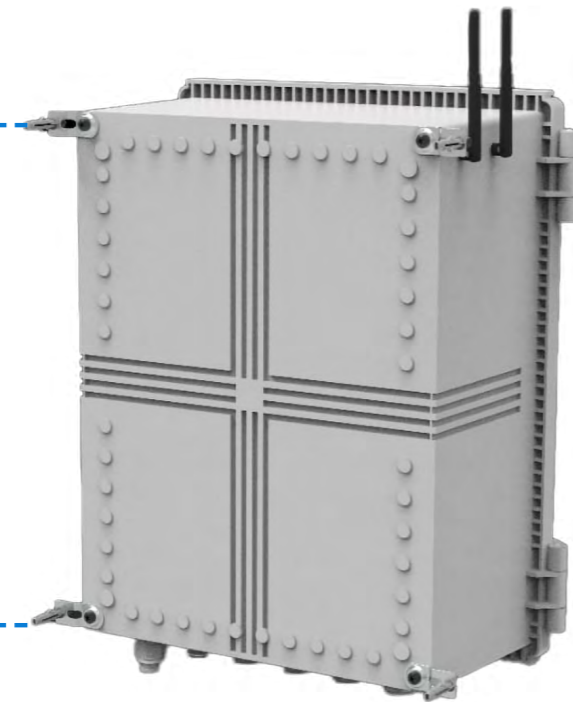

### 2. Drill anchors

Drill anchors in wall and attach controller to wall using the brackets.

MAX Controller / Expansion Box



MAX Package



## 5.2 Connecting to the CPU

The CPU is the far left module of the controller and it contains the following connections:

- 12 digital inputs (dry/active contacts)
- 6 Outputs- relay outputs with shared common

Perform the following steps:

### 1. Verify the SD card exists

SD card containing the controller program should be inserted into the card slot.

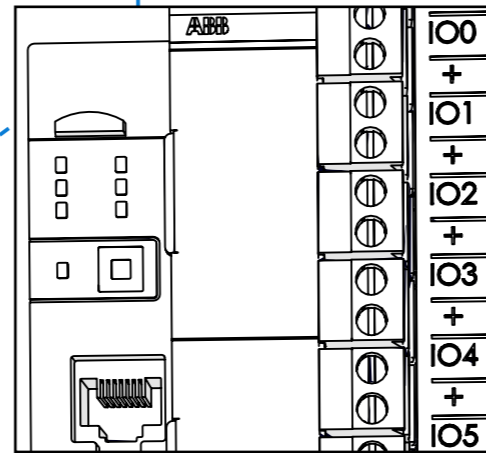
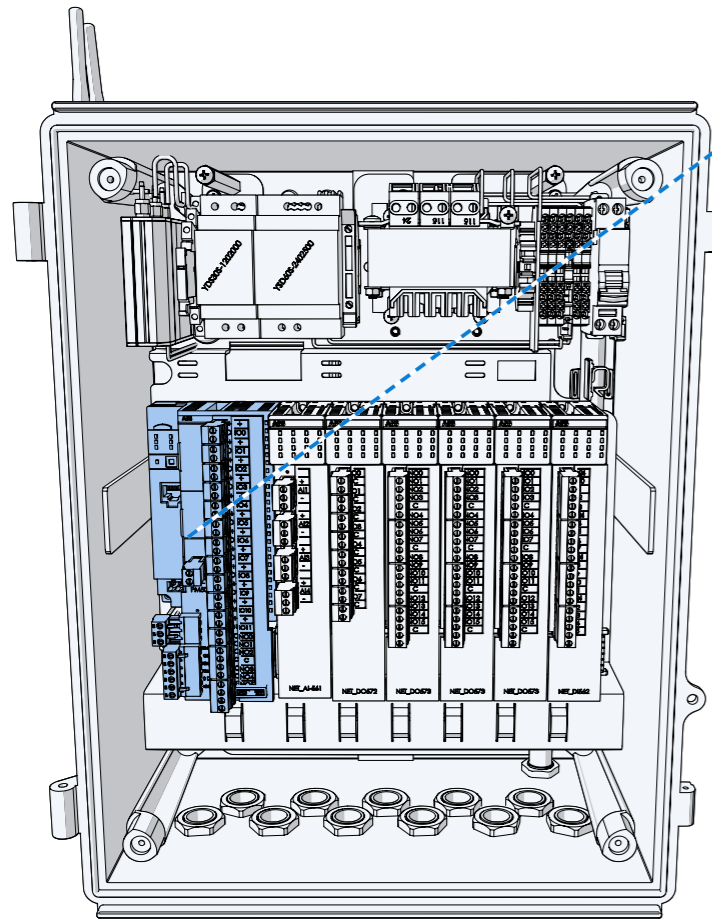

### 2. Pull the connector

Terminal connectors can be disconnected from the module to ease the connection.

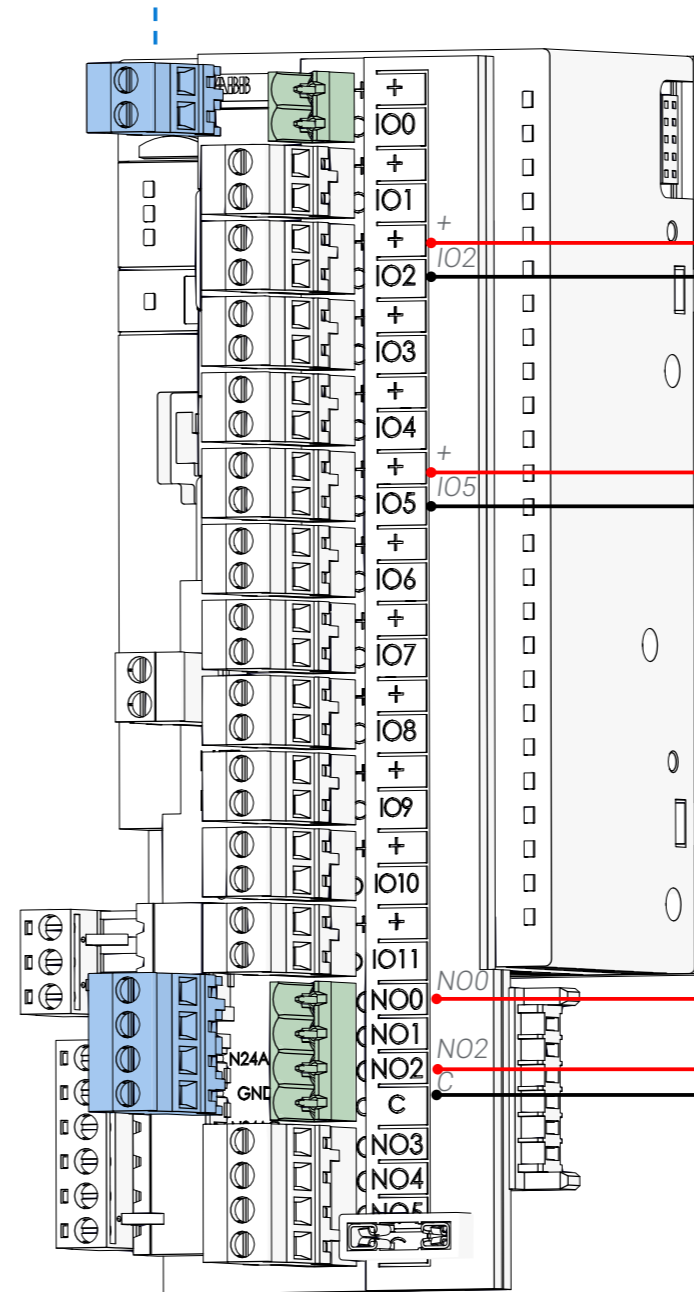

### 3. Connect digital inputs

Connect up to 12 digital inputs. Each input is connected to the (+, common) terminal, and the relevant input number.

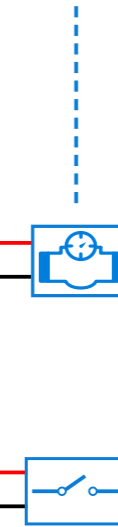

### 4. Connect digital outputs

Connect up to 6 outputs. Each output is connected to the (C, common) terminal, and to the relevant output number.

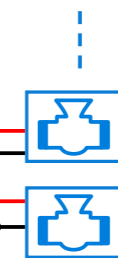

## 5.3 Connecting Expansion Box

- Up to 4 devices per controller
- Enabling distant dosing systems, connected over network
- Expansion of IO capacity
- Based on PLC 5052



## 5.3.1 Expansion BOX settings

Connect an expansion box to your controller

### 2. Communication

The screenshot shows the 'Communication' settings page in the GrowSphere MAX interface. The page title is 'Settings' and the mainline is 'Mainline 1'. The 'Communication' tab is selected, and the 'Expansion Box' sub-tab is active. A table lists four expansion boxes, all with 'Unassigned' status. A blue button at the bottom says 'Add new Expansion box'.

No.	Name	IP Address	Version	Status
1	Unassigned			Unassigned
2	Unassigned			Unassigned
3	Unassigned			Unassigned
4	Unassigned			Unassigned

### 1. Settings

### 3. Expansion Box

### 4. Select 'Add new Expansion Box'.

The controller will detect the expansion box on the network.



## 5.3.2 Detecting the Expansion BOX

Expansion box Detect

No.	Name	IP Address
1	A1EX5052-R-ETHL2300004146	192.168.0.50
2		
3		
4		

Assign

Assign process may take a few minutes.

page 1 of page 0

Done

Expansion box Detect

No.	Name	IP Address
1	A1EX5052-R-ETHL2300004146	192.168.0.51
2		
3		
4		

Assign

Assign process may take a few minutes.

page 1 of page 1

Done



Expansion box connected with default IP

GrowSphere™ by NETAFIM CS TEST Mainline 1 Settings Tue 05 Aug 2025 15:25:37 100

Mainline Configuration Control Configuration Local I/O Remote I/O **Communication** Wiring Diagram

SingleNet Allocation RadioNet Allocation NetRTU (GW) Allocation Weather station Sub-Dosing station **Expansion Box**

No.	Name	IP Address	Version	Status
1	A1EX5052-R-ETHL2300004146	192.168.0.51	1.0.3	Online
2	Unassigned			
3	Unassigned			
4	Unassigned			

Change IP Unassign

Add new Expansion box



### 5.3.3 Change Expansion box IP address

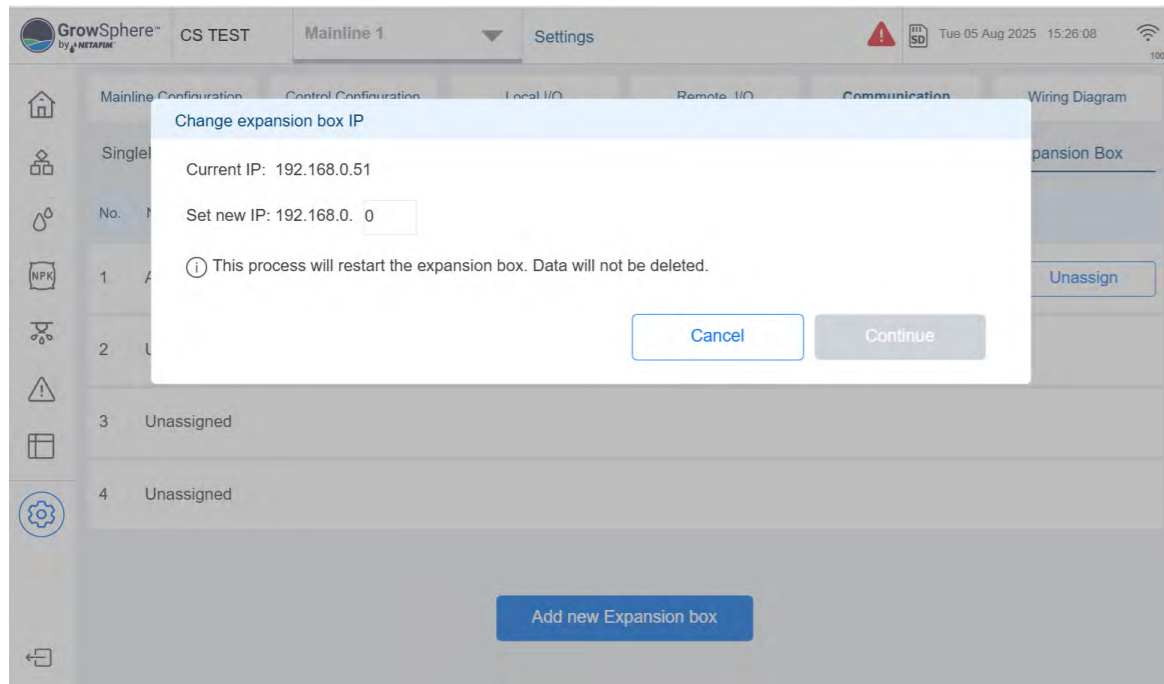

1. Select the correct IP

Local IO added with new name convention

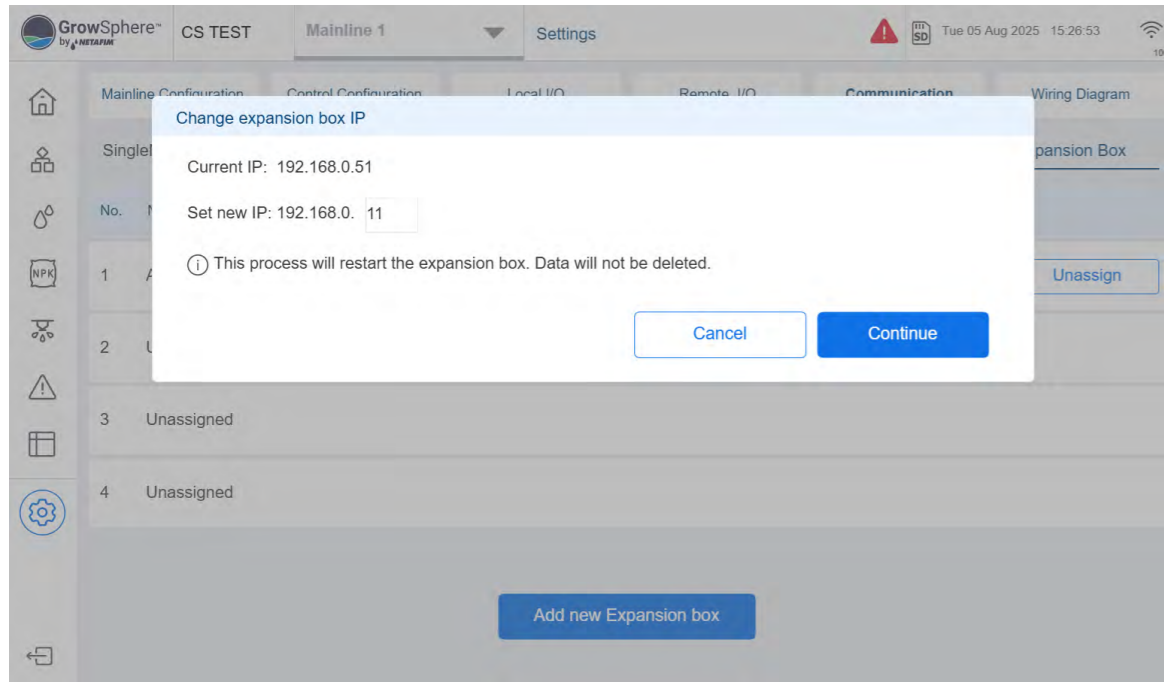
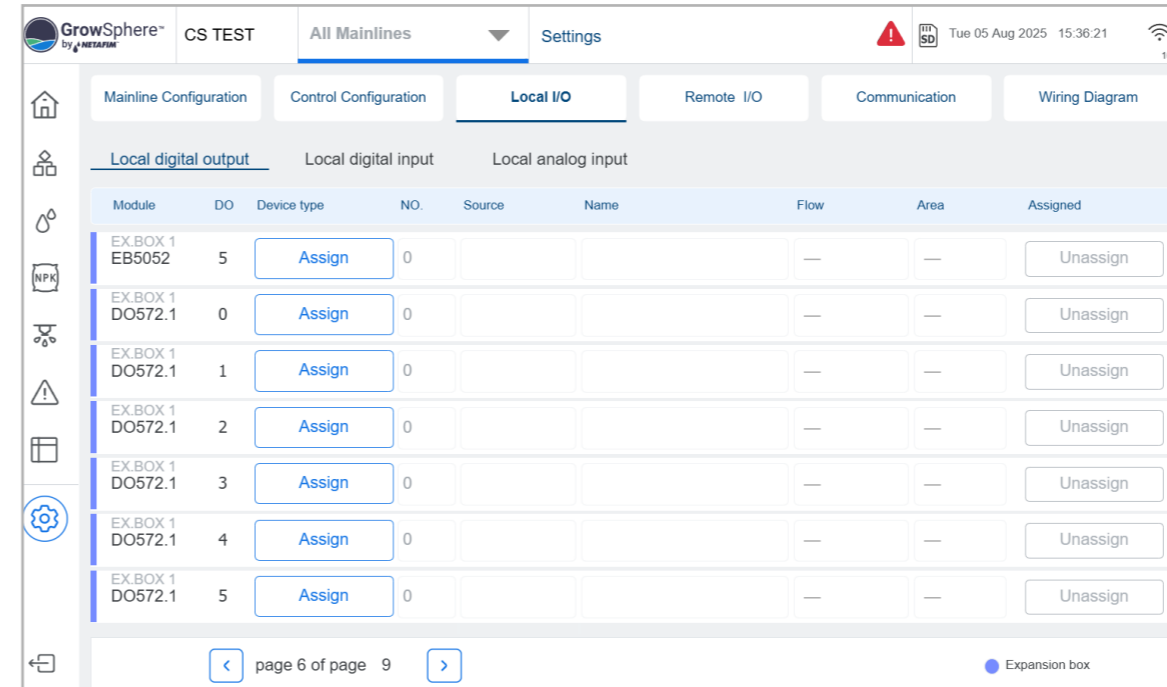

2. Press "Continue"

### 5.3.4 Testing IO on expansion box

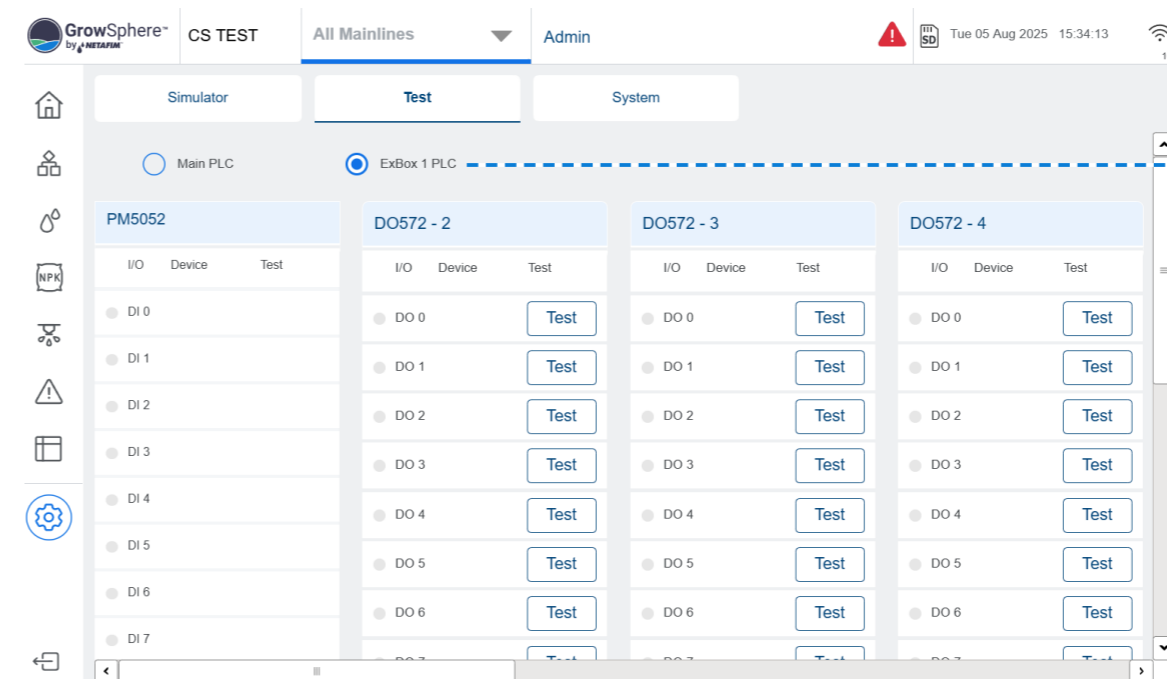

2. Select the expansion box for testing



## 5.4 Connecting Digital Inputs

The DI562 module contains 16 digital inputs (dry/active contact).

Perform the following steps to connect digital inputs:

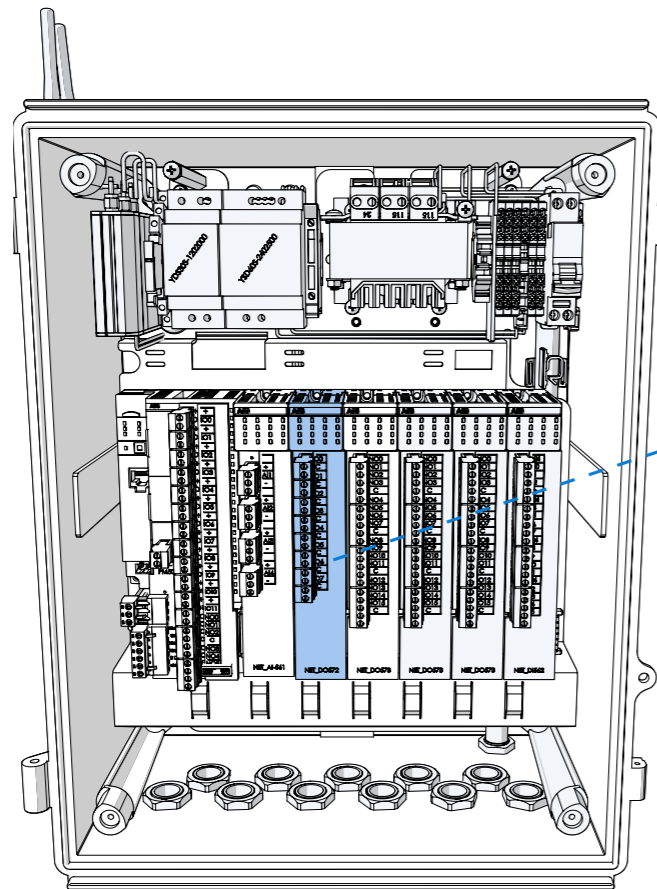

### 1. Pull the connector

Terminal connectors can be disconnected from the module to ease the wiring connection.

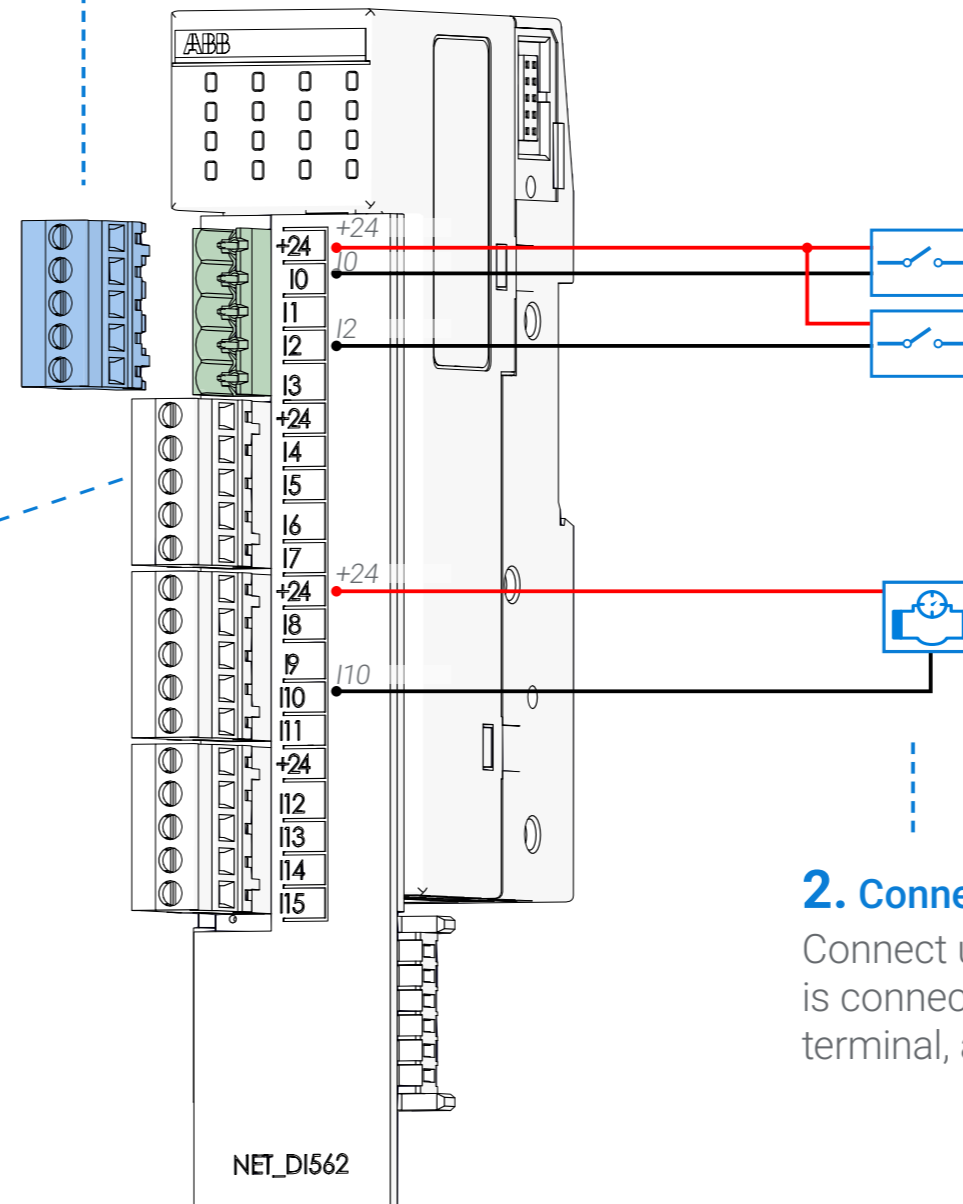

### 2. Connect digital inputs

Connect up to 16 digital inputs. Each input is connected to the (+24VDC common) terminal, and the relevant input number.



## 5.5 Connecting Dosing Outputs

The D0572 module contains 8 TRIAC outputs 24VAC @ 80VA. This module is dedicated to activate venturi dosing pumps at a high speed.

Perform the following steps to connect dosing outputs:

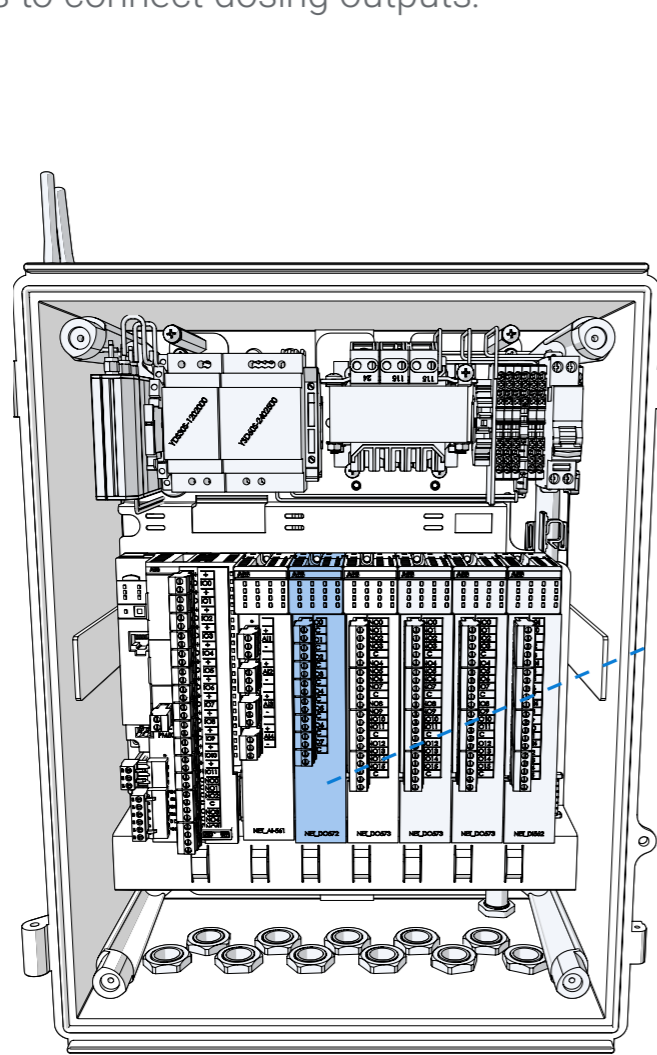

### 1. Pull the connector

Terminal connectors can be disconnected from the module to ease the wiring connection.



### 2. Connect dosing outputs

Connect up to 8 dosing outputs. Each output is connected to the following terminals:

- C - Use the relevant common for each dosing channel (not a shared common)
- The relevant output number (e.g. O0, O1, O2...)



### 3. Attach the connector

Reconnect the terminals connector to the module.



## 5.6 Connecting Digital Outputs

The D0573 module contains 16 digital relay outputs, 24 VAC @ 80 VA, with a separate common for each four outputs.

Perform the following steps to connect digital outputs:

### 1. Pull the connector

Terminal connectors can be disconnected from the module to ease the wiring connection.

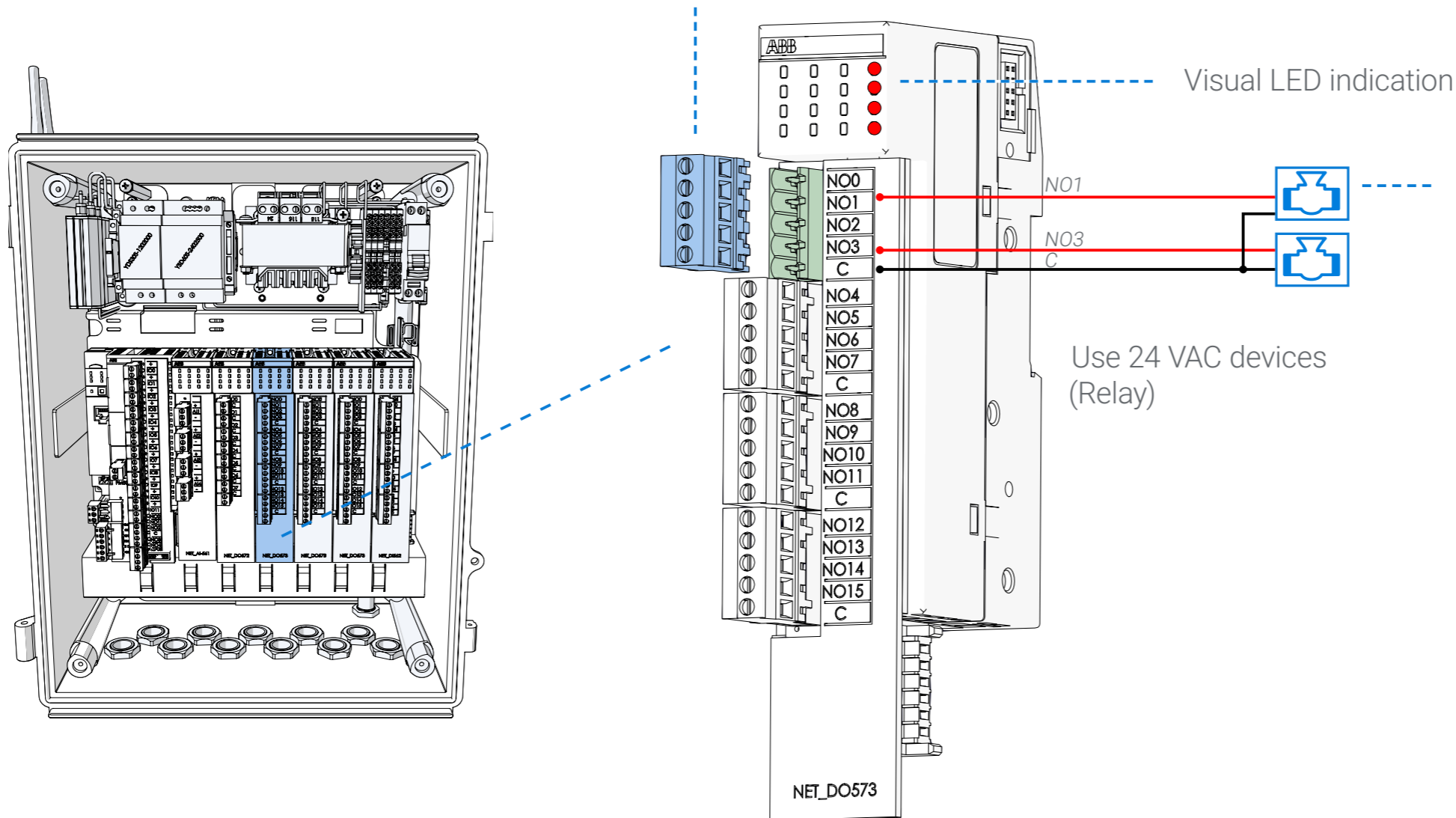

### 2. Connect digital outputs

Connect up to 16 outputs. Each output is connected to the following terminals:

- C - Use the relevant common for each output
- The relevant output number (e.g. NO0, NO1..)

### 3. Attach the connector

Reconnect the terminals connector to the module.

## 5.7 Connecting Analog Inputs

The AI-561 module contains 4 analog inputs.

Perform the following steps to connect analog inputs:

### 1. Pull the connector

Terminal connectors can be disconnected from the module to ease the wiring connection.

### 2. Connect analog inputs

Connect up to 4/8 analog channels. Each analog input is connected to the following terminals:

- (+) - positive DC power supply
- (-) - negative DC power supply
- The relevant input channel signal (e.g. AI1, AI2..)

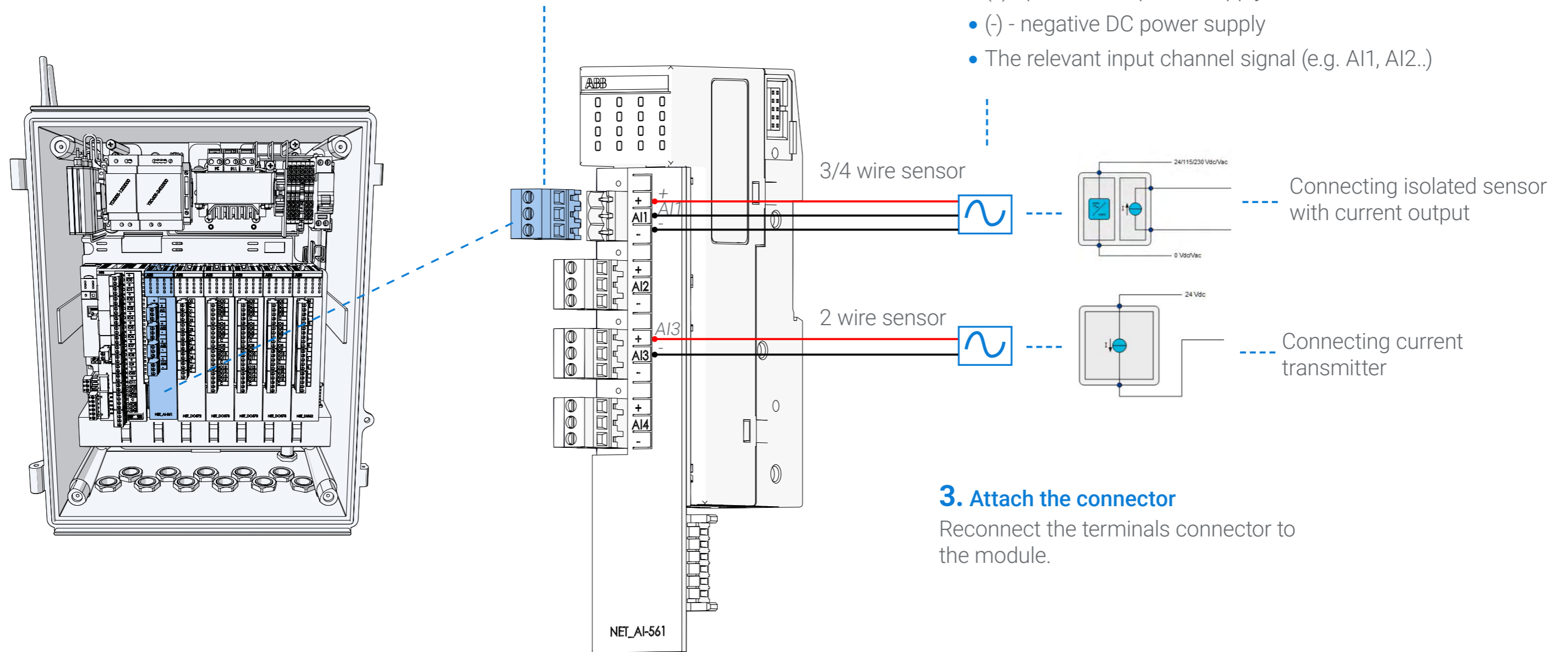

### 3. Attach the connector

Reconnect the terminals connector to the module.



## 5.8 Connecting EC/pH Units

Perform the following steps to connect EC, pH units to the AI-561 module:

### 1. Pull the connector

Terminal connectors can be disconnected from the module to ease the wiring connection.

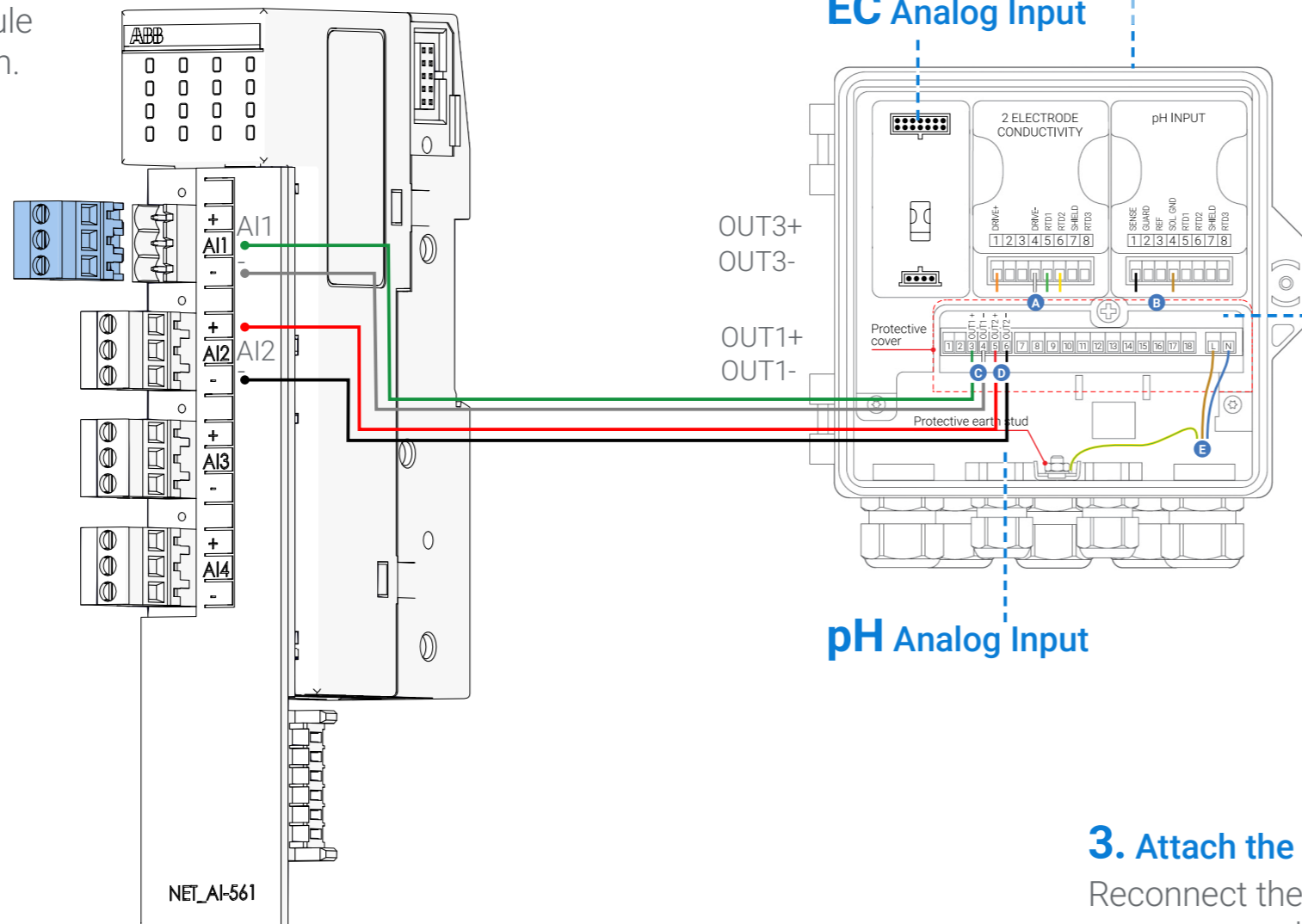

### 2. Connect EC, pH modules

Connect up to 4/8 analog channels. Each analog input is connected to the relevant input channel.

**EC:**

- Terminal AI1 on the module is connected to OUT3(+) on the analog input module.
- Terminal (-) on the module is connected to OUT3(-) on the EC analog input module.

**pH:**

- Terminal AI2 on the module is connected to OUT1(+) on the pH analog input module.
- Terminal (-) on the module is connected to OUT1(-) on the pH analog input module.

### 3. Attach the connector

Reconnect the terminals connector to the module.

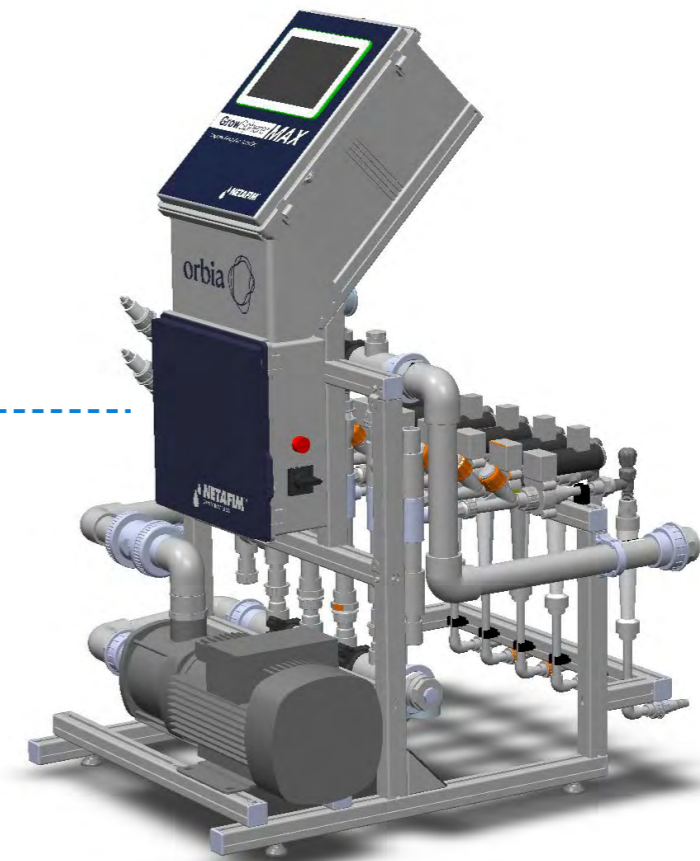

## 5.9 Connecting Energy Meter

- Only ABB meter is supported
- 4 devices per system can be configured
- Energy measurement and accumulation
- Daily accumulation report – added after setting the meter
- Value is added once a day at 00:00

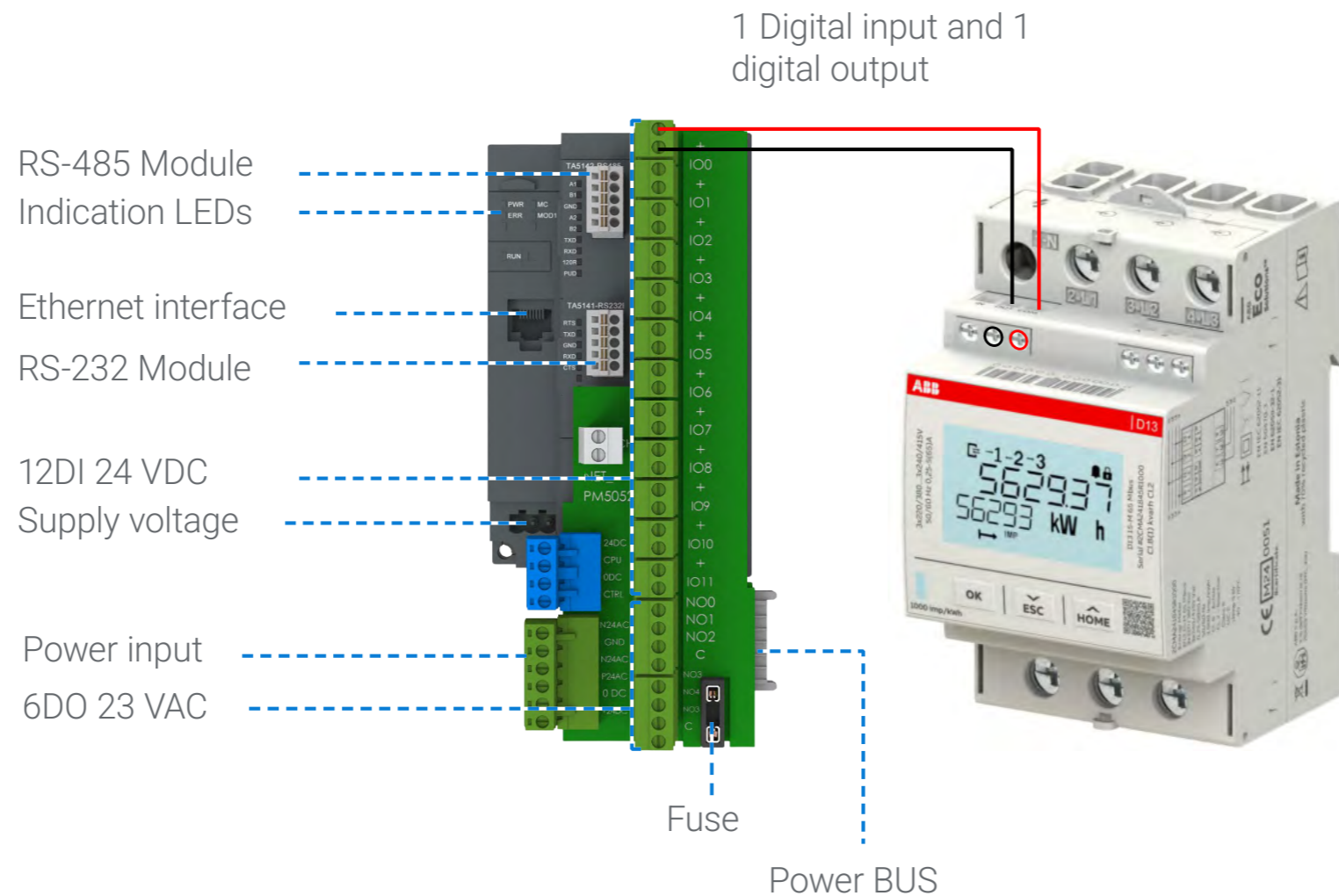
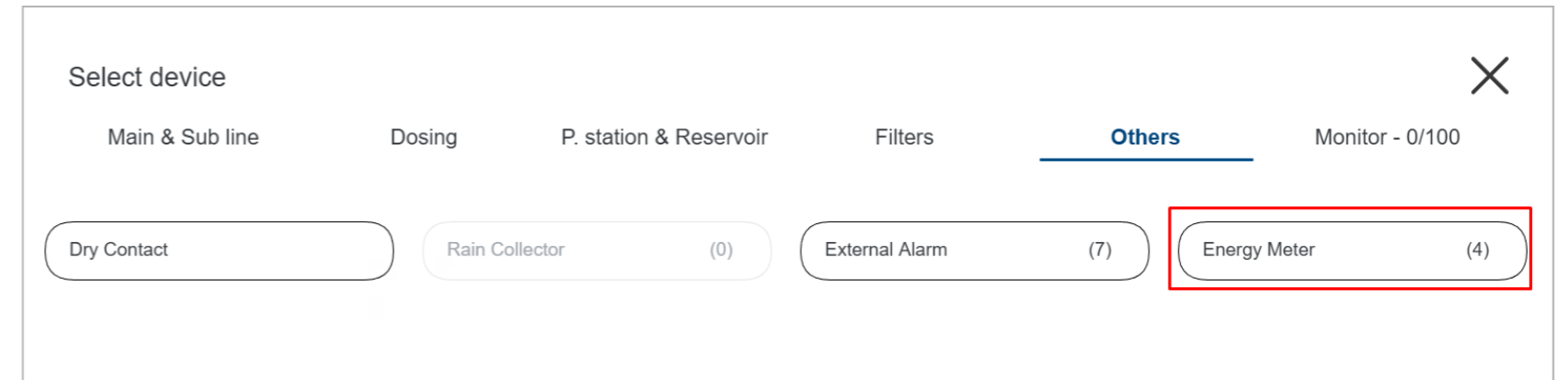

GrowSphere™ by NETAFIM CS TEST All Mainlines Settings Simulation Tue 06 Jan 2026 16:14:55 81

Mainline Configuration Control Configuration **Local I/O** Remote I/O Communication Wiring Diagram

Local digital output Local digital input Local analog input

	Module	DI	Device type	NO.	Source	Name	Type	Rate	Assigned
9.	PM5052	8	External Alarm	1	M.Line1	EXARM1.1	NC	—	Unassign
10.	PM5052	9	Dry Contact	1	M.Line1	DRYC1.1	NO	—	Unassign
11.	PM5052	10	Energy Meter	1	System	ENERGY1	PPkW	1.00	Unassign
12.	PM5052	11	CPS pump WM	1	CPS	PumpWM1	LPP	0.00	Unassign
13.	PM5052	12	AC Fault	1	System	AC Fault	NC	—	Unassign
14.	PM5052	13	Assign	0			—	—	Unassign

page 2 of page 2

Set the Pulses per Kw



## Energy meter accumulation report

Every day at mid-night a line is added per each of the energy meters configured in the system.

GrowSphere™ by NETAFIM CS TEST All Mainlines Reports Simulation Thu 11 Dec 2025 12:35:18

- Mainline
- Controller**
- Reservoir & wells
- Central pump station
- Central pump Daily accumulation
- Weather Station
- Alerts History
- Energy meters accumulation**

GrowSphere™ by NETAFIM CS TEST Mainline 1 Reports Simulation Thu 11 Dec 2025 12:37:48

Energy Meters Accumulation 10.12.2025 Refresh page 1 of page 1

Meter	Start date	Qty
ENERGY0.1	10.12.2025	0 kW



## 6. Controller Configuration

This chapter reviews configuring the controller and includes:

**1/** Getting Started

**3/** Configuring Components

**2/** Dashboard Overview

**4/** GrowSphere™ Max Alerts



## 6.1 Getting Started

### 6.1.1 Preferences and settings

Select the Desktop/Mobile view. In the case of Tablet, select Desktop.  
For Mobile view, Please note:

- This view differs slightly from the PC view and consists of basic settings functionalities.
- The initial settings should be done through the PC view (through PC / Laptop).
- For the main functionalities in the Mobile view, please see next page.

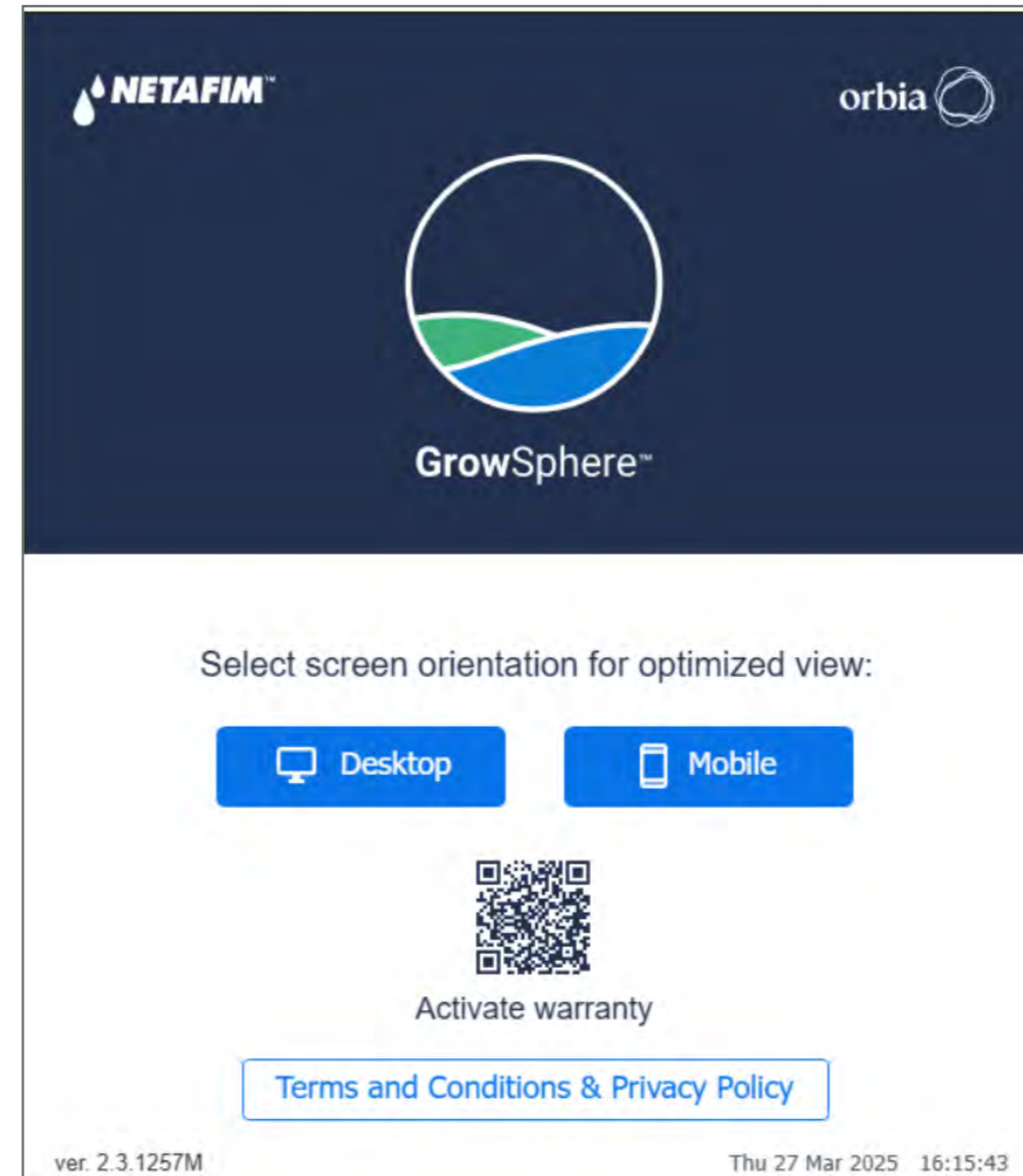

## 6.1.2 Mobile view

- The Mobile view can be selected from the home screen in the **GrowSphere™ MAX** dashboard.
- The main functionalities in the Mobile view are:
  - Mainlines and SCADA view.
  - Irrigation, Dosing, Cooling, and Misting programs - Add, edit, and remove programs.
  - Alerts - View and reset alerts.
  - Weather station – Current status.
  - Irrigation logs.
  - Settings – Disables mainline, disable and reset alerts and change mobile numbers for alerts.
- Unique feature that was added to the Mobile view – Ability to see the ten last cycles of the irrigation program, including the Shifts view (completed and uncompleted):

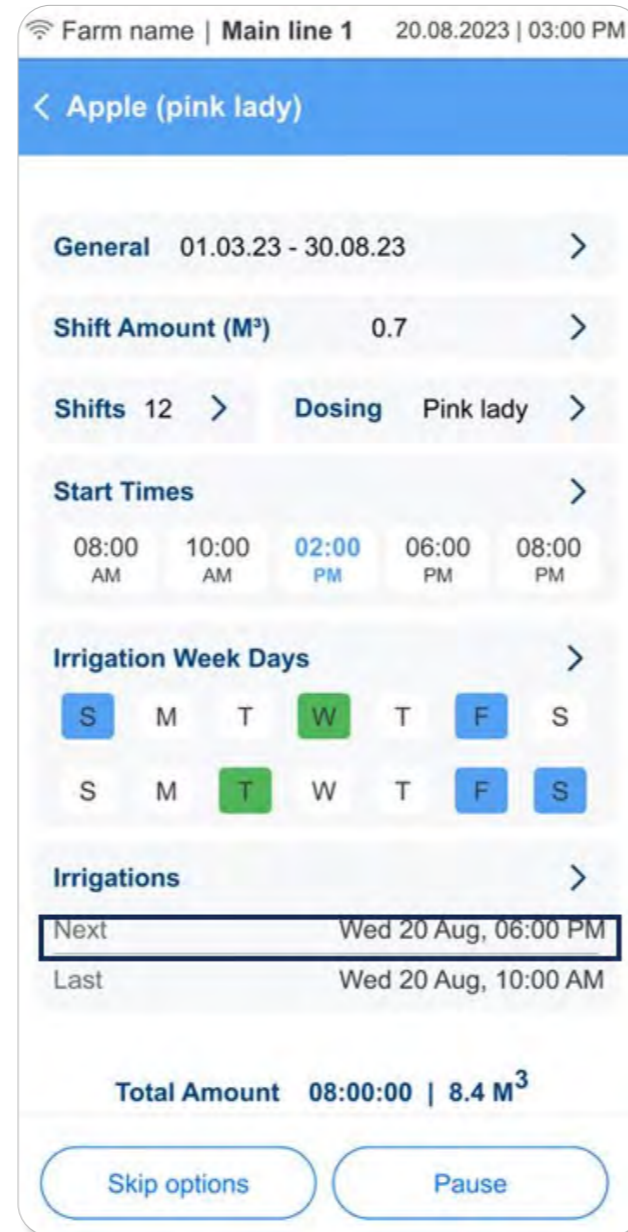

View of the Irrigation program

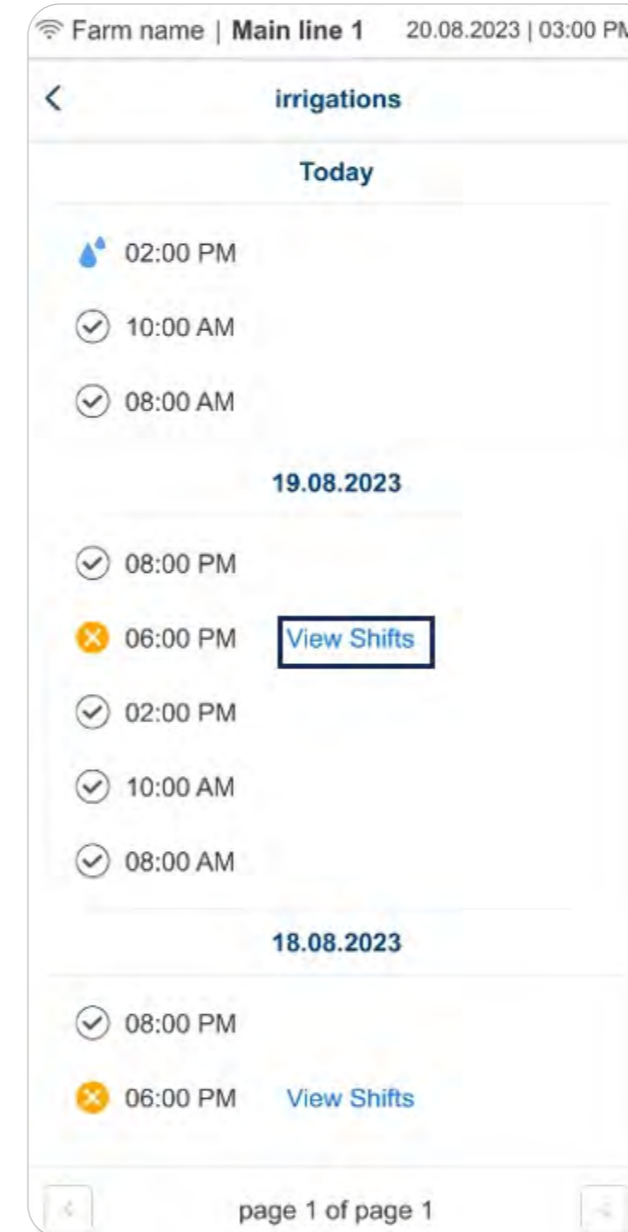

View of the last ten cycles of the irrigation program

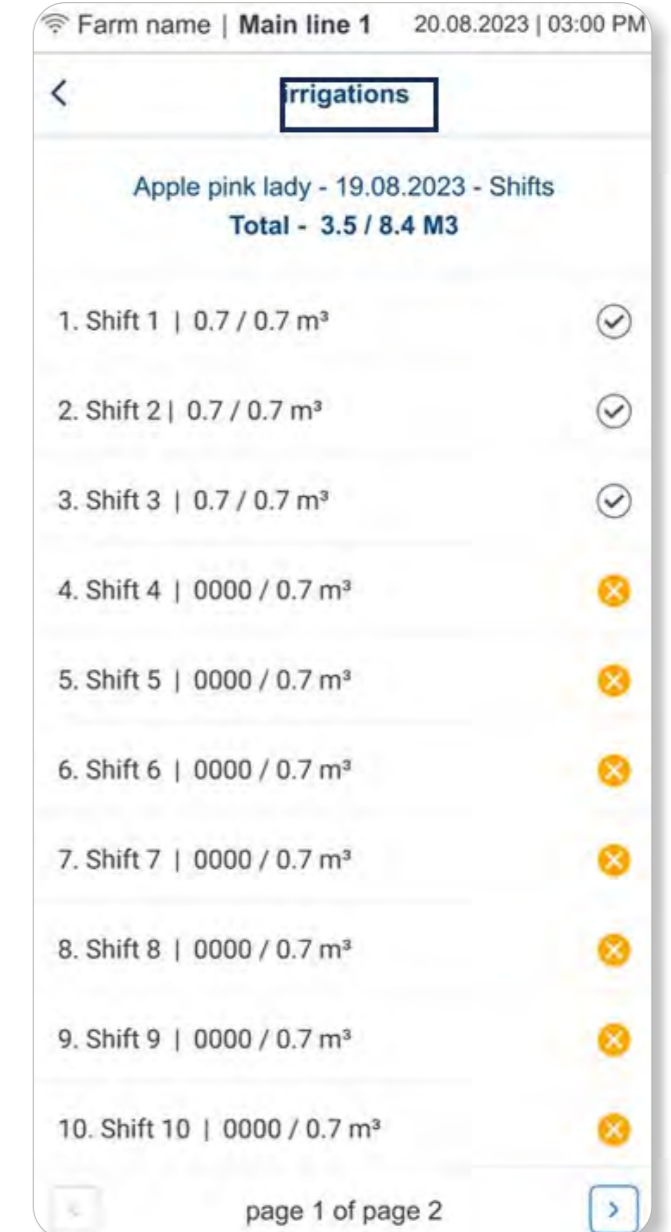

View the Shifts ('explore more' of the desired Irrigation cycle)



### 6.1.3 Home Screen

The home screen is displayed with all the mainlines.

New Mainlines and Reservoir tabs to togel between them

Reservoir Control and Monitoring

Central Pump station monitoring screen

Displays each mainlines preferences:

Select the Mainline to define its parameters

- **Icons:** Icons indicate mainline status.
- **Name:** The mainlines defined in numerical order.
- **Time / m<sup>3</sup>:** Amount of run time left or amount of water flowing through the mainline.

- **Irrigation:** Running irrigation program.
- **Flow:** Irrigation Shift Flow Rate.
- **Pressure:** The pressure in the mainline.
- **Amount:** Shift water Quantity, It can show multiple in case different quantities in shifts.
- **Dosing:** Dosing recipe linked to the irrigation program.
- **Shift:** The shift number currently running.
- **Next in Q:** The shift that is next in queue.

The screenshot shows the 'Home' screen of the GrowSphere MAX controller. At the top, there is a navigation bar with tabs for 'Mainlines', 'Reservoir', and 'Central Pump Station'. The 'Mainlines' tab is selected. Below the navigation bar, there is a table of mainlines. The first mainline, 'Mainline 1', is active and shows a flow rate of 19.91 m³/h, a pressure of 3.40 Bar, and a total amount of 70.00 m³. The second mainline, 'Mainline 2', is also active and shows a flow rate of 40.02 m³/h, a pressure of 2.76 Bar, and a total amount of 02:00 hh:mm. The third and fourth mainlines are inactive and have 'Activate' buttons. The interface also includes a sidebar with icons for home, irrigation, dosing, and settings, and a top status bar with the date and time.

Irrigation	Flow	Pressure	Amount	Dosing	Shift	Next In Q	Last
Banana	19.91 m³/h	3.40 Bar	70.00 m³	Banana	2/2	Blueberry	Blueberry
Test IT	40.02 m³/h	2.76 Bar	02:00 hh:mm	npk2.1	1/2	Greens	Test IT



## 6.2 Dashboard Overview

The main dashboard includes the following sections:

### Sidebar menu

Displayed on every screen

### Home

(see [Home Screen](#))

### SCADA

### Irrigation Programs

### Dosing programs and recipes

### Cooling and Misting

### Alerts

(see [Managing Alerts](#))

### Reports

(see [Viewing Logs](#))

### Configuration

(see [Defining System Preferences](#),  
[Configuring Components](#), and  
[Resetting Accumulation](#))

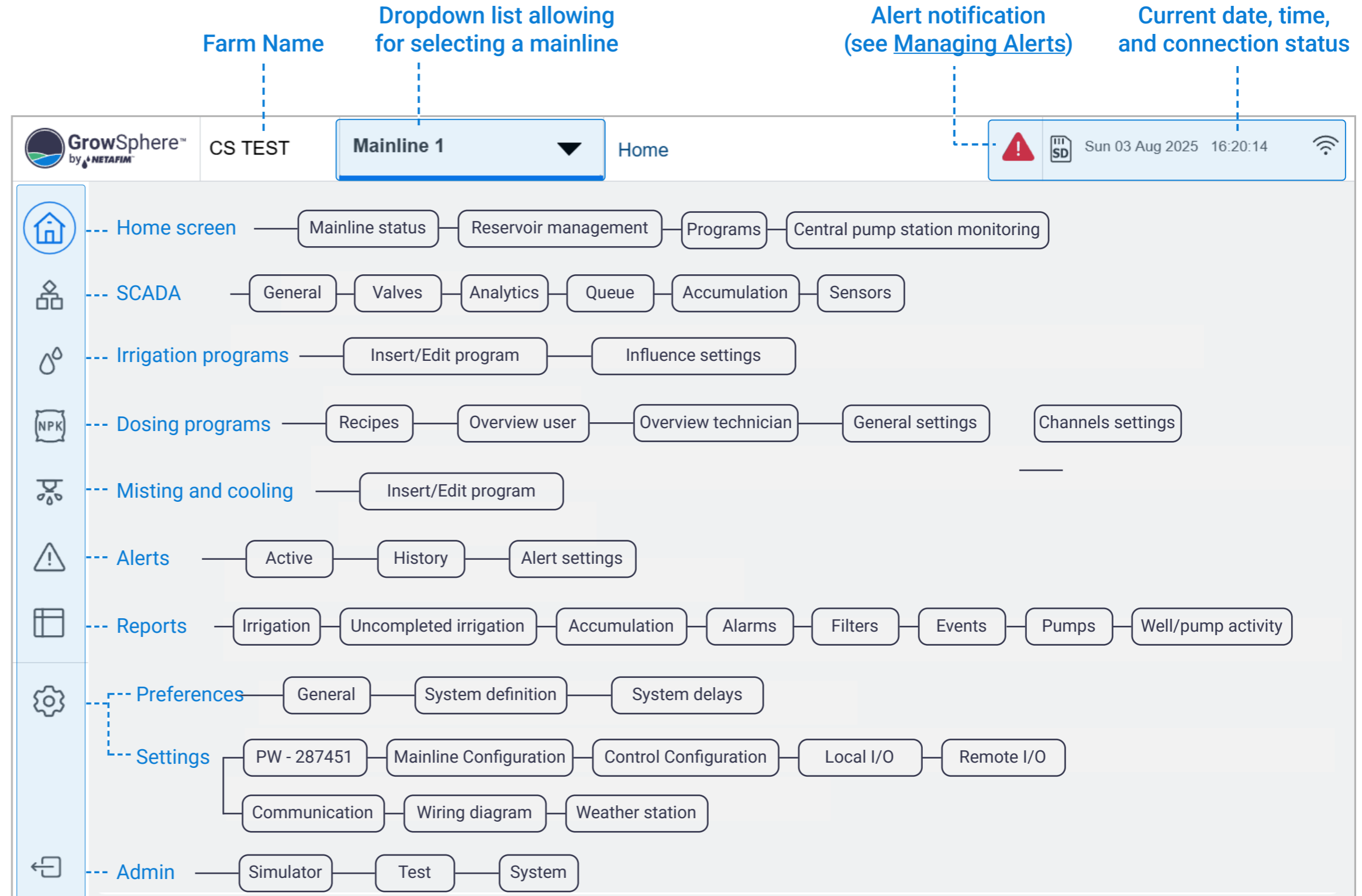

## 6.2.1 General Preferences

Structure changed for screen. Rearranged options or added new.

**3. Verify General tab is selected**

**4. Select language**

**6. Select the time format**

**5. Enter the farm name**

(the farm name will appear on the header)

**1. Tap the Configuration button**

**2. Select Preferences**

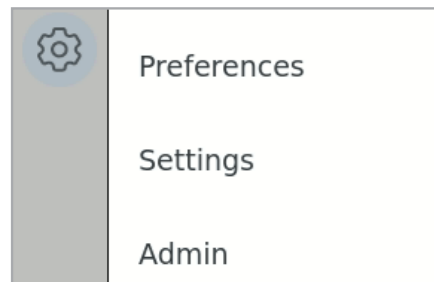

The screenshot shows the 'General' tab of the 'Preferences' screen. The header includes 'Farm' and 'All Mainlines'. The main content area has several sections:
 

- Language:** English
- Units:** Metric
- Time format:** 24 hours
- First day of the week:** Sunday
- Time Zone:** UTC (with 'Daylight Savings' unchecked)
- Current date:** 18 . 03 . 2024
- Date format:** dd/mm/yyyy
- Controller name:** Farm
- Number of mainlines:** 1, 2, 3, 4 (all checked)
- Current UTC time:** 13:27 (with 'Auto' checked)
- Phone number for alarms:** 972528343844

 A 'Send SMS test' button is located at the bottom right. A sidebar on the left contains icons for home, mainlines, water, NPK, and a configuration gear icon. The top right shows a warning icon, SD card icon, date/time, and signal strength.

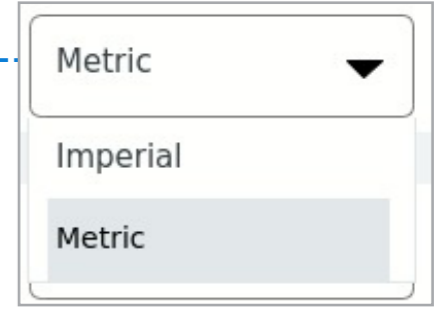

**8. Select the first day of the week**

**9. Set the current date and format**

**11. Select the UTC**  
(Coordinated Universal Time) from the drop-list

**12. SMS Test Button**

**7. Enter the phone number** where text messages will be sent when there's an alarm



## 6.2.2 Set system definitions

Perform the following steps to define mainline preferences:

3. Verify the correct mainline is selected

4. Select the System Definitions tab

Automatic Shift completion

5. Define the relevant system preferences:

The screenshot shows the 'System Definitions' configuration screen for 'Mainline 1'. The interface includes a top navigation bar with 'Mainline 1' selected, a left sidebar with a settings icon, and a main content area with various configuration options. A dashed blue box highlights the 'System Definitions' tab and the 'Automatic shift completion' checkbox, which is checked. Other options include 'Disable Mainline', 'Start day time' (06:00), 'End day time' (23:00), 'Pause Mainline on energy save period', and 'Power off recovery' settings.

1. Tap the Configuration button

2. Select Preferences and type your credentials

Preferences

Settings

Admin

- **Disable Mainline:** This disabling the mainline operation.
- **Automatic Shift Completion:** Automatic Completion of Uncompleted Shifts
- **Start and end time:** Daily irrigation start and end times.
- **Pause Mainline on energy save period:** Tap Edit to define the slot per day for power saving.
- **Power off recovery:** Reset programs in the queue and those irrigating during power off.

Incomplete Irrigation Settings. The settings that define if an irrigation shift is categorized as an Incomplete Irrigation are:

- **Minimal Time Left:** The minimal irrigation time left to completion above which this irrigation shift will be categorized as having incomplete irrigation.
- **Minimal Quantity Left:** The Irrigation amount in m3 left to be completed is greater than 1% of the total irrigation amount required.

**Example:** The minimal irrigation time left to completion is set at 4 minutes. This means that if a program has less than 4 minutes left to complete the irrigation, this shift will not be categorized as having incomplete irrigation.  
\* Important: The minimal time is a highly critical setting.

**Note:** The values for Incomplete Irrigation, Amount Percentage and Time are defined by the Technician on the General Settings screen. The main purpose of these settings is to prevent the irrigation pumps from starting operation for a short period of time to irrigate an incomplete irrigation shift for less than the minimal time.



## 6.2.3 Set system delays

### Filling line delay

The time it takes for water to fill the lines before an irrigation event starts. When the irrigation event begins, and the pumping station is activated, the Filling Time delay is triggered at the start of the irrigation. During this period, the primary line flow rate may be higher than the nominal flow rate of the active irrigation shift. To avoid adding excessive amounts of dosing during this period, the PLC controller compares the Filling Time delay with the Water Before delay values and chooses the longer of the two to delay the dosing.

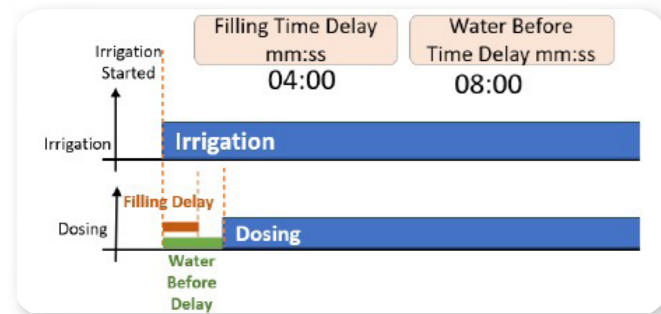

### 2. Select Preferences and type your credentials

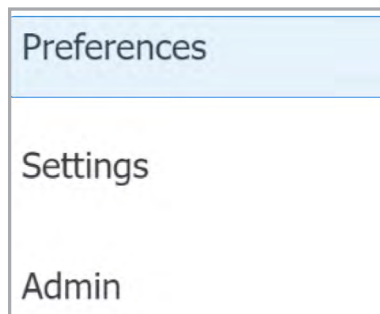

System Delays	On	Off	Unit
Pump/s	00:10	00:00	mm:ss
Main valve delay	00:05	00:04	mm:ss
Irrigation valves delay	00:00	00:10	mm:ss
Line fill delay	01:00		mm:ss

### 1. Define the relevant system preferences:

- **On Delay:** Time between the start of irrigation and when the device starts operating.
- **Off Delay:** Time between the end of irrigation and when the device stops operating.

The example below illustrates the pump and valve on and off delay:

Delays	ON	OFF
Pump/s	10 sec	0 sec
Main Valve Delay	5 sec	5 sec
Irrigation Valves Delay	0 sec	10 sec



## Set Sub Mainline delays

including Sub mainline valve delay, after mainline valve delay. Filling time delay per sub mainline

**2. Verify the correct mainline is selected**

**3. Tap the System Delays tab**

**4. Verify the correct Sub mainline is selected**

**1. Tap the Configuration button**

**5. Define the Sub mainline delay times:**

- Sub-main valve On/Off delay, relative to the main valve delays.
- Filling time definition per Sub-Mainline.

Sub-Mainlines delays		On	Off	Unit	
Sub Main Valve 1 delay (after main valve delay)		00:05	00:04	mm:ss	
Sub Main Valve 2 delay (after main valve delay)		00:05	00:04	mm:ss	
Sub Main Valve 3 delay (after main valve delay)		00:05	00:04	mm:ss	
Sub Main Valve 4 delay (after main valve delay)		00:05	00:04	mm:ss	
Sub Main Valve 5 delay (after main valve delay)		00:05	00:04	mm:ss	
Sub Main Valve 6 delay (after main valve delay)		00:05	00:04	mm:ss	
Filling sub line 1 delay	01:00	mm:ss	Filling sub line 2 delay	01:00	mm:ss
Filling sub line 3 delay	01:00	mm:ss	Filling sub line 4 delay	01:00	mm:ss
Filling sub line 5 delay	01:00	mm:ss	Filling sub line 6 delay	01:00	mm:ss



## Set Program Delays

Perform the following steps to define irrigation program delay times:

**3. Verify the correct mainline is selected**

**4. Tap the System Delays tab**

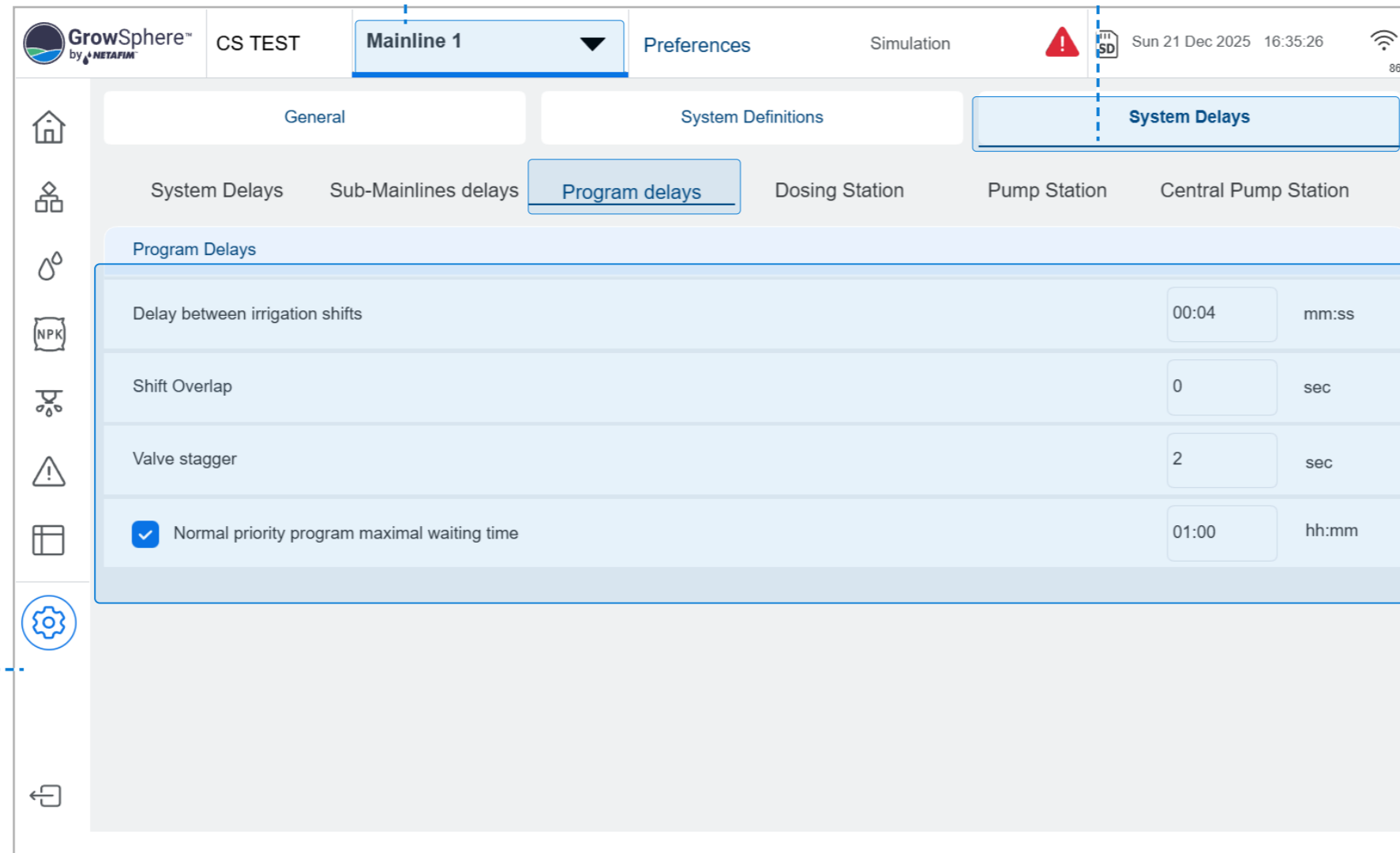

**1. Tap the Configuration button**

**5. Define the irrigation program delay times:**

- **Delay between Irrigation shifts:** Amount of time between when one shift ends and another begins.
- **Shift Overlap:** Time when one shift overlaps the next shift.
- **Valves stagger delay:** Amount of delay time between the activation of successive valves in a given shift.
- **Normal priority program maximal waiting time:** After the defined amount of time, the irrigation program with normal priority that is waiting in the queue will be moved to high priority.

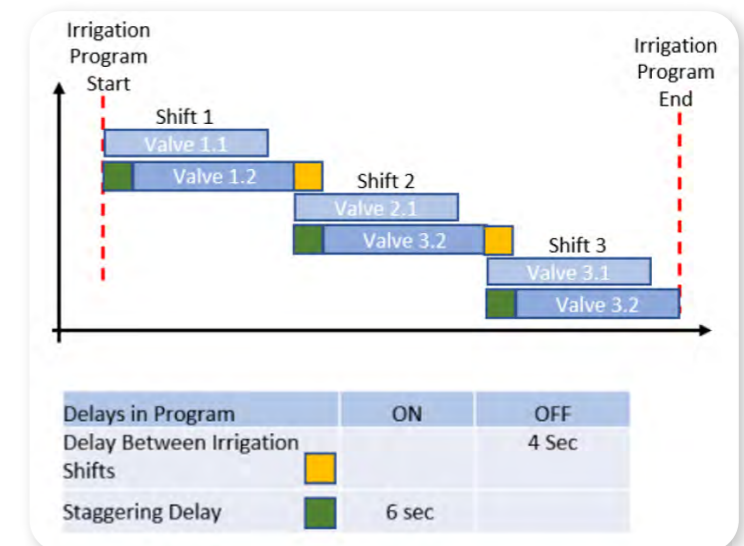

## Dosing station delays

The screenshot shows the 'System Delays' configuration screen in the GrowSphere MAX software. The interface includes a top navigation bar with 'Mainline 1' selected, and a left sidebar with various system icons. The main content area is divided into sections: 'General', 'System Definitions', and 'System Delays'. Under 'System Delays', there are sub-sections for 'System Delays', 'Sub-Mainlines delays', 'Program delays', 'Dosing Station', 'Pump Station', and 'Central Pump Station'. The 'Dosing Station' section is active and displays a table of delay parameters.

Parameter	Value	Unit
Dosing valve minimal on time	1.8	sec
Dosing valve minimal off time	2.0	sec
EC cycle control	15.0	sec
pH cycle control	15.0	sec
Main flow stability time	5.0	sec
Booster pump off delay	20.0	sec

### 1. Define dosing station delays

- **Minimal On Time:** The minimal amount of time the dosing channel must be ON.
- **Minimal Off Time:** The minimal amount of time that the dosing channel can be off.
- **EC control cycle:** The time it takes the fertilizer to travel from the injection point and reach the EC sensor, during which it reacts with the irrigation water. This value changes according to the distance between the injection point and the sensor location, the diameter of the pipe and the flow rate of the active irrigation shift.
- **pH control cycle:** This time takes the acid to travel from the injection point to the pH sensor, during this time it reacts with the irrigation water.
- **Stability delay** is relevant if the active dosing recipe has an EC/pH target set for control. It is a delay at the start of the irrigation shift necessary to attain a stable flow rate. During the stability delay, the nominal flow rate will be used by the PLC controller for the calculation of the proportional amount of fertilizer/chemical injected. After the stability delay the actual flow rate.
- **recorded by the water meter will be used. Booster pump-off delay:** Causes the dosing booster to turn off the defined amount of time after the end of the dosing process.



## Pumping delays

The screenshot shows the 'System Delays' configuration page for a 'Pump Station'. The interface includes a top navigation bar with 'Mainline 1' selected, and a sub-menu with 'Pump Station' highlighted. The main content area contains a table with the following data:

Pump station	On	Off	Unit
Delay between pumps	00:00	00:00	mm:ss
On delay after pump OFF	00:30		mm:ss

- Delay between pumps - pump delay between opening pumps in the pump station
- On delay after pump off - the time to wait after pump was turned off before truing it on again



## Central Pump Station delays

The screenshot shows the 'System Delays' configuration page for the 'Central Pump Station'. The interface includes a top navigation bar with 'MAX CS Demc', 'All Mainlines', and 'העדפות'. Below the navigation, there are tabs for 'General', 'System Definitions', and 'System Delays'. Under 'System Delays', there are sub-tabs for 'System Delays', 'Sub-Mainlines delays', 'Program delays', 'Dosing Station', 'Pump Station', and 'Central Pump Station'. The 'Central Pump Station' sub-tab is active, showing a table of delay settings:

Parameter	Value	Unit
Delay between pumps	00:10	mm:ss
Stability delays	00:30	mm:ss
On delay after pump is off	00:30	mm:ss
Input switch stability time	00:30	mm:ss

- Delay between pumps: when on or off
- Stability delays: alerts will not trigger during this time until pumps and flow are stabilized to prevent false alarms.
- On delay after pump is off: to prevent frequent on and off of the pump.
- Input switch stability time: alerts will not trigger during this time to prevent false alarms.



## 6.3 Configuring Components

This section reviews the configuration and allocations of the devices connected to the controller and includes:

**1/** Defining System Devices

**2/** Sub Mainline Configuration

**3/** Pump Station Configuration

**4/** Configuring Filter Station

**5/** Configuring Dosing Station

**6/** Configuring Valves

**7/** DMS settings

**8/** Configuring Other Devices

**9/** Configuring Reservoir/well

**10/** Central Pump Station

**11/** Allocating Local I/O

**12/** View the wiring diagram

**13/** Mainline External Pause



### 6.3.1 Defining System Devices

Define the number of valves and the devices that are connected to each mainline.

**NOTE**

Need to define all the devices that are part of the hydraulic model regardless if they are connected locally or remotely.

**3. Tap the Configuration tab**

**4. Tap the Mainline tab**

**6. Select each device that is part of the irrigation system**

Note that some devices require additional parameters to be entered..

**Remote is for setting SubStation**

**1. Tap the Configuration tab**

**2. Select Settings and type your credentials**

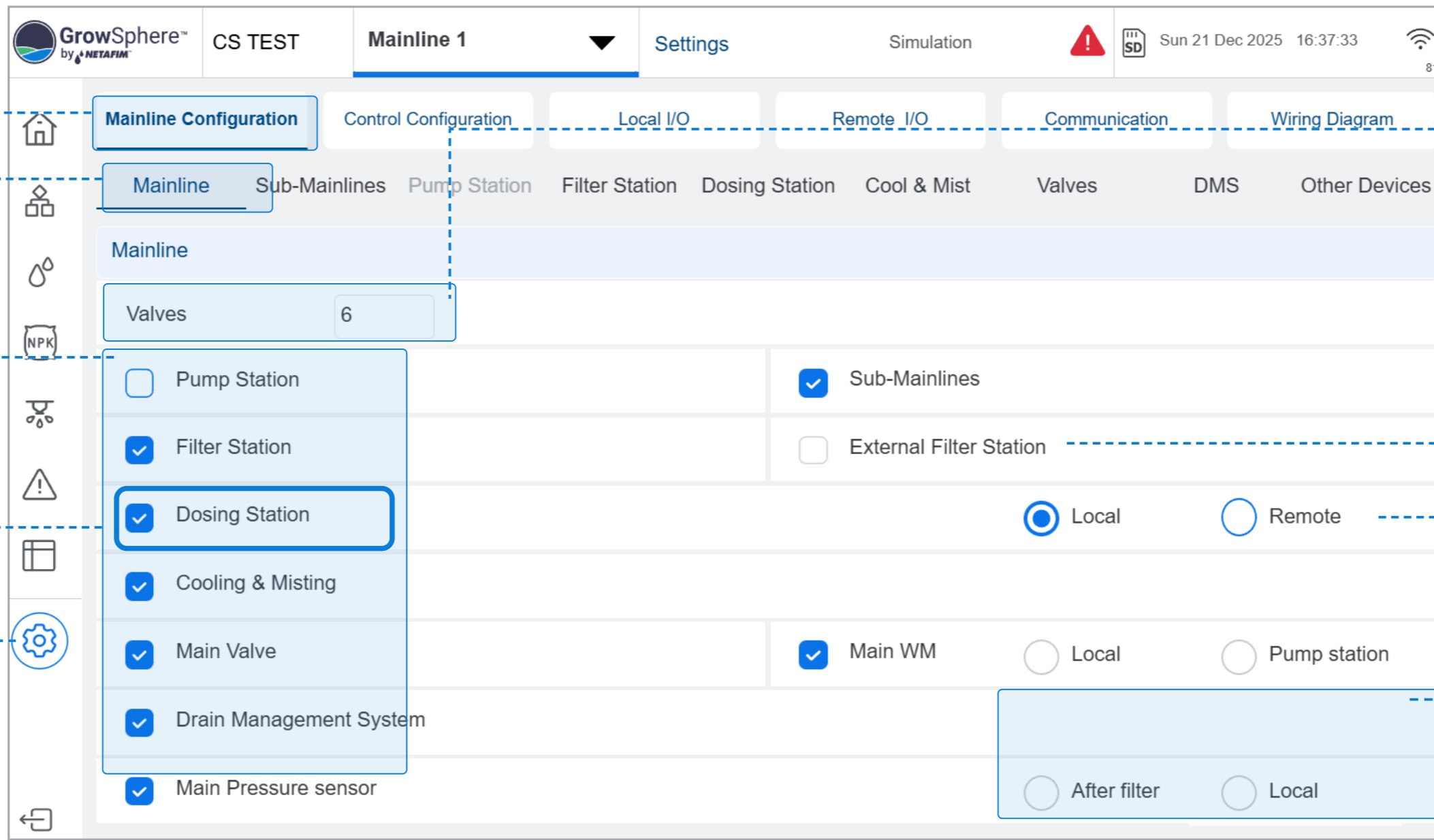

**5. Enter the number of valves**

This value represents the total number of valves used in the system.

**7. External filter function**

External filter function is enabled when Filtron controller is in use and a Digital Input is connected to the controller to count flashes.

**8. Set remote**

Set remote when working with Netajet5G/Sub station.

**9. Select the location**

The water meter / pressure sensor can be located at the pump station/after filter or at the mainline (local).

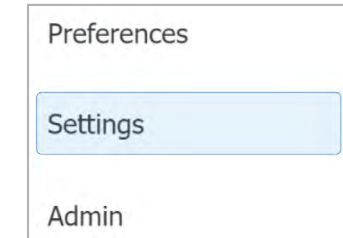

## 6.3.2 Sub Mainline Configuration

Up to 6 Sub Mainlines per Mainline

- each supporting:
  - Sub main valves.
  - Sub main WM
  - Sub main PS
- Filing time delay per Sub Mainline
- Maximal flow alarm per Sub Mainline
- Maximal flow validation per Sub Mainline and Mainline
- Irrigation valves, Sub Mainline allocation
- A Shift can have valves from different sub mainlines.

The screenshot shows the GrowSphere MAX SCADA interface for 'Mainline 2'. The top bar includes 'GrowSphere™ by NETAFIM', 'CS TEST', 'Mainline 2', 'SCADA', 'Simulation', a warning icon, 'Sun 27 Jul 2025 11:51:00', and a signal strength icon. The main content area has tabs for 'General', 'Valves', 'Analytics', 'Queue', 'Accumulation', and 'Sensors'. Below the tabs, there's a 'Test IT' section with 'Skip Options' and 'Pause Mainline' buttons. A progress bar shows 'Started: 07.27.2025 | 11:50', 'Shift: 2/2', '00:46/01:00', 'Total: 01:46/02:00 hh:mm', and 'Next: Test IT 07.27.2025 | 12:00'. The central diagram shows two sub-mainlines, 1 and 2, each with a pump and valve. Below the diagram, it displays '0.0 Bar' and '0.0 m³/h' for both, with 'Nominal: 20.0' and 'Total: 3 Valves' for sub-mainline 1, and 'Total: 2 Valves' for sub-mainline 2. At the bottom, there are buttons for 'Mainline', 'Sub mainline', 'Shifts', 'Pump station', 'Filter station', and 'Dosing'.



## Setting the Sub-Mainline

In Local/Remote I/O digital outputs, define the pump wells.

Pumps can be connected via radio.

2. Mainline

1. Settings

The screenshot displays the 'Mainline Configuration' settings for 'Mainline 3'. The interface includes a top navigation bar with 'Settings' selected, and a left sidebar with a gear icon for 'Settings' and a house icon for 'Mainline'. The main content area shows a list of configuration options:

- Valves:** 9
- Pump Station:**
- Sub-Mainlines:**  (highlighted with a blue box and a dashed line pointing to the text '3. Turn on "sub-mainlines"')
- External Filter Station:**
- Filter Station:**
- Dosing Station:**  Local  Remote
- Cooling & Misting:**
- Main Valve:**  Main WM  Local  Pump station
- Drain Management System:**
- Main Pressure sensor:**  After filter  Local

3. Turn on "sub-mainlines"



## Sub-Mainlines Tab in settings

The screenshot shows the 'Sub-Mainlines' configuration screen. The top navigation bar includes 'Mainline Configuration', 'Control Configuration', 'Local I/O', 'Remote I/O', 'Communication', and 'Wiring Diagram'. The 'Sub-Mainlines' tab is active, showing a table with columns for 'Sub-Mainline', 'Name', 'Maximal flow', 'Sub main valve', 'Water meter', 'Pressure sensor', 'Virtual', and 'Valves'. A table with 2 rows is visible. A blue dashed arrow points from the 'Valves' column of the first row to a detailed view of 'Sub-Mainline 1' on the right. This view shows a list of valves (001 V1 to 005 V5) with their flow rates (20.0 m³/h) and checkboxes for selection. A 'Done' button is at the bottom right.

Sub-Mainline	Name	Maximal flow	Sub main valve	Water meter	Pressure sensor	Virtual	Valves
1	Sub-Mainline 1	10.0	<input checked="" type="checkbox"/>	<input type="checkbox"/>	<input checked="" type="checkbox"/>	<input type="checkbox"/>	0 / 6
2	Sub-Mainline 2	20.0	<input type="checkbox"/>	<input checked="" type="checkbox"/>	<input type="checkbox"/>	<input type="checkbox"/>	0 / 6

### 1. Set the number of Sub-mainlines

Define the following for each sub-mainline:

### 2. Name

### 3. Maximal Flow

### 4. Sub main valve

### 5. Sub water meter

### 6. Sub pressure sensor

### 7. Virtual – if checked, will be included in virtual WM calculation

### 8. Link the valves per sub-mainline



## I/O allocation

### 1. Local I/O

### 2. Local digital output

### 3. Define the sub-mainline devices

GrowSphere™ by NETAFIM CS TEST All Mainlines Settings Simulation Sun 27 Jul 2025 11:39:12

Mainline Configuration Control Configuration **Local I/O** Remote I/O Communication Wiring Diagram

Local digital output Local digital input Local analog input

Module	DO	Device type	NO.	Source	Name	Flow	Area	Assigned
DO573.1	8	Dosing Channel	3	D.Statio1	DCH1.3	50.00 L/h	—	Unassign
DO573.1	9	Dosing Channel	4	D.Statio1	DCH1.4	600.00 L/h	—	Unassign
DO573.1	10	Pump	1	M.Line2	PMP2.1	70.00 m³/h	—	Unassign
DO573.1	11	MainValve	1	M.Line2	MVLV2.1	—	—	Unassign
DO573.1	12	Sub Main valve	1	M.Line2	SUBMV2.1	—	—	Unassign
DO573.1	13	Sub Main valve	2	M.Line2	SUBMV2.2	—	—	Unassign
DO573.1	14	Assign	0			—	—	Unassign

page 3 of page 5



## Sub-mainline delays settings

### 1. System delays

### 2. Sub mainline delays

relative to the main valve delays.

### 3. Filling time definition per Sub-Mainline.

Sub-Mainlines delays	On	Off	Unit
Sub Main Valve 1 delay (after main valve delay)	00:05	00:04	mm:ss
Sub Main Valve 2 delay (after main valve delay)	00:05	00:04	mm:ss
Sub Main Valve 3 delay (after main valve delay)	00:05	00:04	mm:ss
Sub Main Valve 4 delay (after main valve delay)	00:05	00:04	mm:ss
Sub Main Valve 5 delay (after main valve delay)	00:05	00:04	mm:ss
Sub Main Valve 6 delay (after main valve delay)	00:05	00:04	mm:ss

Filling sub line 1 delay	01:00	mm:ss	Filling sub line 2 delay	01:00	mm:ss
Filling sub line 3 delay	01:00	mm:ss	Filling sub line 4 delay	01:00	mm:ss
Filling sub line 5 delay	01:00	mm:ss	Filling sub line 6 delay	01:00	mm:ss



## Monitoring the Sub-mainline in SCADA

1. Pressure
2. Flow
3. Sub main valve operation status
4. Nominal flow
5. Linked valves



## Defining the shift in the irrigation program

New shift screen under irrigation program

**1. Containing valves in groups per sub-mainline**

**2. It is allowed to mix valves from different Sub-mainlines in the same program—shift**

The screenshot shows a configuration screen for a shift named "Shift 01". At the top, there are input fields for "Time(hh:mm)" set to "00:00", "Factor(%)" set to "100", and "Dosing" set to "No recipe". Below this, there are tabs for "Mainline" and "Sub-Mainline 1" through "Sub-Mainline 6". Under "Sub-Mainline 1", three valve groups are listed: "001 V1" (checked), "002 V2", and "003 V3", each with a flow rate of "20.0 m³/h". At the bottom, a status bar shows "Mainline nominal flow 20.0 m³/h out of 45.0 m³/h" and "Sub-Mainline Total flow 20.0 m³/h out of 60.0 m³/h". A "Done" button is located at the bottom right.

**3. Flow validation per sub-mainline and mainline**



## 6.3.3 Pump Station Configuration

### Pump Station Start Setting

The pump station is in charge of delivering the required amount of water for the active Shift with the required nominal flow. Pump Stations provide the mainline the required flow rate for the running shift. The users may define only one pump station per mainline. The maximal number of pumps per station is 3.

- Pumps Belong to a Station:** In this case, the group of pumps selected for the Station, operate together to deliver the flow rate required by the Hydraulic Manager for the current irrigation shift (valves) in progress. The pump station activates the pump/s in the right combination, in order to supply the required flow rate. The pumps are activated and deactivated according to the pump/s delays setup.
- Pumps Belong to a valve or number of valves:** In this case a valve or valves are linked to a specific pump in the Pump Station. When one of these valve/s is active (running), then the pump that belongs to them is activated. This pump is activated and deactivated according to the pump delays setup.

The screenshot displays the 'Mainline Configuration' settings for 'Mainline 3'. The interface includes a top navigation bar with 'Settings' and a date/time display. Below the navigation, there are tabs for 'Mainline Configuration', 'Control Configuration', 'Local I/O', 'Remote I/O', 'Communication', and 'Wiring Diagram'. Under 'Mainline Configuration', there are sub-tabs for 'Mainline', 'Sub-Mainlines', 'Pump Station', 'Filter Station', 'Dosing Station', 'Cool & Mist', 'Valves', 'DMS', and 'Other Devices'. The 'Mainline' sub-tab is active, showing a 'Valves' input field set to '9'. Below this, there are several configuration rows with checkboxes and radio buttons:

- Pump Station
- Filter Station
- Dosing Station
- Cooling & Misting
- Main Valve
- Drain Management System
- Main Pressure sensor
- Sub-Mainlines
- External Filter Station
- Local (selected) /  Remote
- Main WM /  Local /  Pump station
- After filter /  Local



## Setting for 3 Pumps in Pump Station

GrowSphere™ by NETAFIM CS TEST Mainline 2 Settings Simulation Sun 03 Aug 2025 16:39:03

Mainline Configuration Control Configuration Local I/O Remote I/O Communication Wiring Diagram

Mainline Sub-Mainlines **Pump Station** Filter Station Dosing Station Cool & Mist Valves Other Devices

Pump station

Number of Pumps

Pump	Overload	Stand alone	Water meter	Nominal flow	Minimal flow
1 PMP2.1	<input type="checkbox"/>	<input type="checkbox"/>	<input type="checkbox"/>	70.0	1
2	<input type="checkbox"/>	<input type="checkbox"/>	<input type="checkbox"/>	0.0	0
3	<input type="checkbox"/>	<input type="checkbox"/>	<input type="checkbox"/>	0.0	0

Input pressure switch

1. Select the number of Pumps for this station

2. Water source low pressure switch or minimal water source level

- Overload protection if exist
- Stand Alone to allow assigning a pump to a valve
- Water meter if exist
- Nominal flow
- Minimal flow



## Setting for 2 Pumps in Pump Station and one Pump Stand Alone

The screenshot shows the GrowSphere MAX Controller Configuration interface. The top navigation bar includes 'Mainline Configuration', 'Control Configuration', 'Local I/O', 'Remote I/O', 'Communication', and 'Wiring Diagram'. The 'Pump Station' sub-tab is selected. The 'Number of Pumps' is set to 1. Below this is a table with columns: Pump, Overload, Stand alone, Water meter, Nominal flow, and Minimal flow. The table contains three rows for pumps 1, 2, and 3. Pump 1 (PMP2.1) has 'Stand alone' checked. Pump 2 has 'Stand alone' checked. Pump 3 has 'Stand alone' checked. A callout box points to the 'Stand alone' checkbox for Pump 2.

Pump	Overload	Stand alone	Water meter	Nominal flow	Minimal flow
1 PMP2.1	<input type="checkbox"/>	<input checked="" type="checkbox"/>	<input type="checkbox"/>	70.0	1
2	<input type="checkbox"/>	<input checked="" type="checkbox"/>	<input type="checkbox"/>	0.0	0
3	<input type="checkbox"/>	<input type="checkbox"/>	<input type="checkbox"/>	0.0	0

**3.** Pump 2 is set to Stand Alone, to be linked to specific irrigation valves.



## Pumps Outputs Selection

4

5

6. Select the pumps on the system.

Module	DO	Device type	NO.	Source	Name	Flow	Area	Assigned
PM5052	0	Pur	Valve (1)	Dosing Booster (0)	Condition active (0)	m <sup>3</sup> /h	—	Unassign
PM5052	1	Mai	MainValve (0)	Alarm (0)	EC Pre-Control open (1)		—	Unassign
PM5052	2	Valv	Pump (3)	Selector (0)	EC Pre-Control close (1)	m <sup>3</sup> /h	1.00 ha	Unassign
PM5052	3	Valve	2	M.Line1	BL2	20.00 m <sup>3</sup> /h	1.00 ha	Unassign
PM5052	4	Valve	3	M.Line1	BL3	20.00 m <sup>3</sup> /h	1.00 ha	Unassign
PM5052	5	Valve	4	M.Line1	BL4	20.00 m <sup>3</sup> /h	1.00 ha	Unassign
DO573.1	0	Valve	5	M.Line1	BANANA1	20.00 m <sup>3</sup> /h	15.00 ha	Unassign

page 1 of page 9

Expansion box



## Pumps Inputs Selection

7

GrowSphere™ by NETAFIM CS TEST All Mainlines Settings Simulation Sun 24 Aug 2025 15:15:27

Mainline Configuration Control Configuration **Local I/O** Remote I/O Communication Wiring Diagram

Local digital output Local digital input Local analog input

Module	DI	Device type	NO.	Source	Name	Type	Rate	Assigned
PM5052	7	Well Watermeter	2	Reservoirs	WellM1.2	LPP	0.00	Unassign
PM5052	8	Assign	0			—	—	Unassign
PM5052	9	Dry Contact	1	M.Line1	DRYC1.1	NO	—	Unassign
PM5052	10	Assign	0			—	—	Unassign
PM5052	11	Assign	0			—	—	Unassign
PM5052	12	AC Fault	1	System	AC Fault	NC	—	Unassign
PM5052	13	Assign	0			—	—	Unassign

page 2 of page 4 Expansion box

Select device

Main & Sub line Dosing **P. station & Reservoir** Filters Others Monitor - 0/100

Well Watermeter (1)	Reservoir Emerg. high (0)	Reservoir Emerg. low (1)	Well Low Level switch (0)
Well High Level switch (0)	CPS outlet WM (1)	CPS inlet switch (0)	CPS pump WM (2)
CPS pump OL (0)	CPS pump switch (0)	CPS non critical alert (0)	CPS critical alert (0)

**8. Select the pumps water meters and input pressure switch according to the elements on the system.**



## Valves Selection to the Pump Station

Pump that was set as "Stand Alone" in the pump configuration screen, can be assigned to specific valve.

GrowSphere™ by NETAFIM | CS TEST | Mainline 2 | Settings | Simulation | Mon 04 Aug 2025 16:51:24

Mainline Configuration | Control Configuration | Local I/O | Remote I/O | Communication | Wiring Diagram

Mainline | Sub-Mainlines | Pump Station | Filter Station | Dosing Station | Cool & Mist | **Valves** | Other Devices

Device type	NO.	Source	Name	Flow	Area	Pump	Assigned	Module/RTU	DO
Valve	1	M.Line2	V1	20.00 m³/h	20.00 ha	station	✓		0
Valve	2	M.Line2	V2	20.00 m³/h	20.00 ha	station	✓		0
Valve	3	M.Line2	V3	20.00 m³/h	20.00 ha	station	✓		0
Valve	4	M.Line2	V4	20.00 m³/h	20.00 ha	station	✓		0
Valve	5	M.Line2	V5	20.00 m³/h	20.00 ha	station	✓		0

GrowSphere™ by NETAFIM | CS TEST | Mainline 1 | Settings | Simulation | Mon 04 Aug 2025 16:53:03

Mainline Configuration | Control Configuration | Local I/O | Remote I/O | Communication | Wiring Diagram

Mainline | Sub-Mainlines | Pump Station | Filter Station | Dosing Station | Cool & Mist | **Valves** | Other Devices

Device type	NO.	Source	Name	Flow	Area	Pump	Assigned	Module/RTU	DO
Valve	1	M.Line1	BL1	20.00 m³/h	1.00 ha	station	✓	PM5052	2
Valve	2	M.Line1	BL2	20.00 m³/h	1.00 ha	none	✓	PM5052	3
Valve	3	M.Line1	BL3	20.00 m³/h	1.00 ha	station	✓	PM5052	4
Valve	4	M.Line1	BL4	20.00 m³/h	1.00 ha	1	✓	PM5052	5
Valve	5	M.Line1	BANANA1	20.00 m³/h	15.00 ha	2	✓	DO573.1	0
Valve	6	M.Line1	BANANA2	20.00 m³/h	1.00 ha	station	✓	DO573.1	3



## Pump Station Delays

9

Pump station	On	Off	Unit
Delay between pumps	00:00	00:00	mm:ss
On delay after pump OFF	00:30		mm:ss

10

11. ON and OFF delays between pumps activation and deactivation

12. Delays for the pump that was turns OFF to be turn ON again



## Pump Station Alerts Setting

The screenshot shows the 'Pump Station Alerts Settings' screen in the GrowSphere MAX application. The top navigation bar includes 'Farm', 'Mainline 1', and 'Alerts'. The status bar displays 'Simulation 21.2°C', a warning icon, 'Sun 10 Dec 2023 14:27:31', and a Wi-Fi icon. The main content area is titled 'Pump Station Alerts Settings' and contains a table with two columns: 'Value' and 'Critical Value'. Each row represents an alert type with its description, value, delay, action, and SMS notification status.

Description	Value	Delay (sec)	Action	sms	Critical Value	Delay (sec)	Action	sms
Pump station input switch		60s	Alert Only	<input type="checkbox"/>		120s	Alert Only	<input type="checkbox"/>
Pump Overload		60s	Alert Only	<input type="checkbox"/>		120s	Alert Only	<input type="checkbox"/>

\* Pump Station input pressure switch to indicate if pressure exist or not.

13

14



## 6.3.4 Configuring Filter Station

Perform the following steps to configure the filter station parameters:

### 1. Defined by the user

### 2. Located upstream of the filters

for increasing water pressure on the filter station units

### 3. The Differential Pressure Switch

measures the water pressure differential between the filter inlet and outlet

### 4. The irrigation shift pauses until flushing is done

### 5. Works independently of irrigation.

If not selected, flushing only occurs during active irrigation

### 6. Will keep main valve on when flushing.

Needed in cases where the main valve is located before the filter.

### 7. Number of Filter Units:

The number of filters that belong to the filter station. The maximal number is 32

### 8. Filter flushing will occur during filling time

### 9. An alert is generated if flow switch pulses don't match filter activation pulses

### 10. This can be measured locally or at the measurement point in the pump station.

### 11. The current dosing recipe in the irrigation shift will be paused during the filter flushing process and resumed afterward.



2. Select the Configuration tab

3. Select the Filter Station tab

For Pump Station configuration, please go to chapter: Mainline Pump Station

1. Enter settings

The screenshot shows the GrowSphere MAX Controller Configuration interface. The top navigation bar includes 'Mainline 1' and 'Settings'. Below this, there are tabs for 'Mainline Configuration', 'Control Configuration', 'Local I/O', 'Remote I/O', 'Communication', and 'Wiring Diagram'. Under 'Mainline Configuration', there are sub-tabs for 'Mainline', 'Sub-Mainlines', 'Pump Station', 'Filter Station', 'Dosing Station', 'Cool & Mist', 'Valves', and 'Other Devices'. The 'Filter Station' tab is selected, showing the 'Filter Station Program' settings. The settings are organized into two columns:

Time between cycles (hh:mm)	01:00	Water between cycles	100
DP Analog Value (Bar/PSI)	5.0	Filter Flushing Time (mm:ss)	00:10
Required Flushing Pressure (Bar/PSI)	0.0	Delay Between Filters (mm:ss)	00:10
Delta Pressure Start Delay (mm:ss)	00:05	<input checked="" type="checkbox"/> Filters Rotation	
Main Filter Valve Delay	00:10	DP Reiteration	5

At the bottom of the page, there is a navigation bar with a home icon, a back arrow, 'page 2 of page 2', and a forward arrow.

## 5. Define the filter station parameters:

- **Time between cycles (hh:mm)**
- **DP Analog value (Bar/PSI)**
- **Required Flushing Pressure:** The minimum pressure needed to run the flushing process, to achieve effective flushing of the filters.
- **Delta Pressure Start Delay:** This parameter sets a delay in mm:ss and starts counting down when a signal from the DP device is received. If the signal remains on, the filter flushing process is triggered.
- **Main Filter Valve Delay:** A delay (mm:ss) to activate the Main Valve or Filter Booster Pump before flushing the first filter unit in the sequence. Range: 00:01 to 60:00.
- **Water between cycles**
- **Filter Flushing Time:** The duration of flushing for each filter unit (mm:ss). Filter units flush one at the time.
- **Delay Between Filter:** The time (mm:ss) between the end of flushing of one filter unit and the beginning of flushing of the next unit.
- **Filter Rotation:** If activated, each flushing process starts with the next filter unit in the sequence.
- **DP Reiteration:** No. of consecutive flushing cycle signals from DP Switch. Range: 1-10. Alert issued if exceeded. Default: 3.



### 6.3.5 Set dosing station configuration

- Define the numbers of dosing channels and agitators and activate them
- Select the connected devices that related to the dosing station:

2. Select the Configuration tab

3. Select the Dosing Station tab

1. Enter settings

### 5. Define the dosing station parameters:

- **Extensive:** This option is chosen when the dosing station/ dosing channels are far away from the controller. In this case, the dosing channels are activated by remote terminal units.
- **Intensive:** This option is typically chosen when precise control over the injection of fertilizers and chemicals, including EC and PH control, is required.
- **Dosing Channels:** The fertilizer meter measures and calculates the dosing channel flow rate. In the proportional method, the dosing meter reading is used as a flow reference only.
- **Mixing valve:** Selecting the Mixing Valve option will enable it. for its configuration go to NPK-->General settings
- **Booster pump:** If the dosing booster is selected, the option to check the correct checkbox for pump overload will be enabled.
- **Dosing Meter:** define if dosing meter exist per channel
- **Agitator** - Indicates if there is an active agitator for that channel.
- **Fert Tank Level** - indicates an active tank level for that channel tank, it will be visualized in the SCADA
- **Booster pump O.L** - indicates and active Over Load sensor active for the booster.
- **Dosing Pressure Switch** - indicates active pressure switch for the booster.
- **Agitator pump** - indicates active pump for the agitator activity.
- **Ec/pH sensors** - indicate the number of sensors available for this dosing system.

Sensor connections				
Dosing station name/number				
Sensor type	Sensor	Range	Local input number	Remote input number
4-20 mA	EC1	0 – 10mS		
4-20 mA	EC2	0 – 10mS		
4-20 mA	pH1	0 – 14		
4-20 mA	pH2	0 – 14		
Dry	Press switch	ON/OFF		
0-5 Volts	Pressure	0-10 bar		



## Configuring Dosing Channel Settings

Perform the following steps to configure the dosing channel settings:

1. Activate the connected channels.
2. Define each channel's Type, Minimum and Nominal flow, Reaction, DM rate, and deviations.

Active	ID	Dosing Channel	Channel Type	Minimum Flow L/h	Nominal Flow L/h	Reaction	Dosing Meter Rate	Low deviation	High deviation
<input checked="" type="checkbox"/>	1	DCH1	Venturi Soleno	1.0	60.0	EC	0.1 LPP	30 %	40 %
<input checked="" type="checkbox"/>	2	DCH2	Venturi Soleno	1.0	60.0	EC	0.1 LPP	30 %	40 %
<input checked="" type="checkbox"/>	3	DCH3	Venturi Soleno	1.0	60.0	EC	0.1 LPP	30 %	40 %
<input checked="" type="checkbox"/>	4	DCH4	Venturi Soleno	1.0	60.0	Acid	0.1 LPP	30 %	40 %

- **Channel Type** - The options are Venturi, Electric, Hydraulic. The Default is Venturi Solenoid
- **Minimal Flow** - The minimal flow rate that the dosing channel can work. The units are l/h and g/h. Default is: 1.0
- **Nominal Flow**: it is a nominal flow rate that the dosing channel was set manually at the channel. Sometimes it is known as a maximal dosing channel flow rate. The units are l/h and g/h. Default is 1.0
- **Reaction** - the type of fertilizer or chemical that has an influence on the EC/pH Control The options are: Passive, EC, Acid, and Alkaline The default is Passive.
- **Dosing Meter Ratio** - When was set a Dosing Meter then the user will set the pulse rate for each Dosing Meter. The units are PPL (pulses per liter), LPP (liter per pulse). Imperial Units: PPG (pulses per gallon), GPP (gallons per pulse). The Default is LPP.
- **Low Deviation** - the calculated minimal percentage that the dosing valve can be open compared to minimal deviation % settings
- **High Deviation** - The calculated maximal percentage that dosing valve can be open compare maximal deviation % settings



## Configuring Tanks parameters

1. Write the Tank's names/ Chemical type

2. Set the tanks volume or dimensions

3. When the Tanks shape is conical, then set the factor

4. Select agitator Active or Not

5. Select Tanks Level Sensor if there is a connected sensor.

ID	Tank name	Tank volume	Tank height	Tank Top diameter	Conical tank	Level in tank	ACT CONTENT L	ACT CONTENT %	Agitators	Level senso
1	T1	1000L	--	--	<input type="checkbox"/>	--	--	--	<input checked="" type="checkbox"/>	<input type="checkbox"/>
2	T2	1000L	--	--	<input type="checkbox"/>	--	--	--	<input checked="" type="checkbox"/>	<input type="checkbox"/>
3	T3	1000L	--	--	<input type="checkbox"/>	--	--	--	<input checked="" type="checkbox"/>	<input type="checkbox"/>
4	T4	150L	--	--	<input type="checkbox"/>	--	--	--	<input checked="" type="checkbox"/>	<input type="checkbox"/>

## Configuring Dosing EC/pH control Settings

When the dosing recipe defines target values for EC and pH, the proportional 1:1000 dosing method must be used.

In this case, the PLC controller adjusts the proportional quantities in the dosing recipe to ensure a constant EC/pH value is delivered based on the set EC/pH target values.

The parameters included in the calculations for the EC/pH control are explained in the next two pages:

**2. Select the General Settings tab**

**1. Select the Fertilizer Dosing button**

The screenshot shows the 'General Settings' tab for 'EC pH control'. The 'Intensive' radio button is selected. The 'EC' and 'pH' checkboxes are checked. The configuration table is as follows:

Parameter	Value
Control Cycle	15.0 Sec
Delta	0.2
Fine Tuning	50.0
Coarse Tuning	50.0
Deadband	0.1
Integ time	10.0 Sec
Control	Sensor 1
Avg filter speed	5

Parameter	Value
Control Cycle	15.0 Sec
Delta	0.2
Fine Tuning	25.0
Coarse Tuning	50.0
Deadband	0.1
Integ time	10.0 Sec
Control	Sensor 1
Avg filter speed	5

Parameter	Value
Minimal on time	1.8 Sec
Minimal off time	2.0 Sec
Water flow stability time	5.0 Sec
Booster off delay	20.0 Sec
Max Time Between Pulses	60 sec

**3. Select Extensive or Intensive**

**For an intensive and Extensive description:**  
See page 67. If extensively selected, the EC/pH reaction settings will be disabled.

**4. Define the parameters**

See next page.

**5. Max time between pulses**

for dosing meter.



## Dosing Parameters:

- **Control cycle:** The duration that the fertilizer needs to travel from where it is injected to where the EC sensor is located. During this duration, the fertilizer mixes with the irrigation water. The value of this cycle depends on several factors such as the distance between the injection point and the sensor location, the diameter of the pipe used, and the flow rate.
- **Delta:** The maximal deviation allowed between the readings of two EC/pH sensors. If the deviation, exceed this value, an alert will be triggered.
- **Fine Tuning:** Applied when the EC/pH values are close to the target (i.e., 0.6 deviations from the target value). The higher the set number, the faster the EC/pH target will be reached, and the more fertilizer will be injected.
- **Coarse Tuning:** Applied when the EC/pH value is far from the target. The higher the number is set, the more rapid the fertilizer quantities will be increased in order to reach the target values more quickly.  
It is important to consider that as a result of fast (aggressive) changes, the EC/pH values will overshoot the EC/pH target. If slow (less aggressive) changes are made, it will take longer to reach the EC/pH target, with less deviation as a result.
- **Deadband:** Defines a range around the reading value that the system will ignore changes of the readings.
- **Integ:** Defines how fast the system will correct between high and low deviation.
- **Control:** Enables defining what sensor/s is used to control the process.
- **Avg. Filter Speed:** Defines how often the average of the two sensors readings is calculated. 0- defines a slow update of the calculated average. 10 - the calculated average is calculated often.
- **Minimal On Time:** The minimal amount of time the dosing channel must be on. This should be set based on the minimum activation time of the control valve or dosing channel motor.
- **Minimal Off Time:** The minimal amount of time that the dosing channel can be off. This value is important to ensure good dosing distribution.
- **Water Flow Stability Time:** A delay at the start of the irrigation shift necessary for the water meter to record a stable flow rate. Relevant when using EC/pH dosing control.
- **Booster Off Delay:** Causes the dosing booster to turn off the defined amount of time after the end of the dosing process.

The screenshot displays the 'Dosing' configuration page for 'Mainline 1' in a simulation environment. The interface includes a navigation menu with options like 'Recipes', 'Overview User', 'Overview Technician', 'General Settings', and 'Channels Settings'. The main content area is divided into sections for 'EC pH control', 'Mixing valve', 'Tanks', and 'Agitators'. Under 'EC pH control', there are two modes: 'Extensive' and 'Intensive', with 'Intensive' selected. Below this, there are two sensor control sections: 'EC sensors' and 'pH sensors'. Each section has a 'Control' dropdown set to 'Sensor 1' and an 'Avg filter speed' dropdown set to '5'. The 'EC sensors' section has a 'Control Cycle' of 15.0 Sec, 'Delta' of 0.2, 'Fine Tuning' of 50.0, 'Coarse Tuning' of 50.0, 'Deadband' of 0.1, and 'Integ time' of 10.0 Sec. The 'pH sensors' section has a 'Control Cycle' of 15.0 Sec, 'Delta' of 0.2, 'Fine Tuning' of 25.0, 'Coarse Tuning' of 50.0, 'Deadband' of 0.1, and 'Integ time' of 10.0 Sec. At the bottom, there are five input fields for: 'Minimal on time' (1.8 Sec), 'Minimal off time' (2.0 Sec), 'Water flow stability time' (5.0 Sec), 'Booster off delay' (20.0 Sec), and 'Max Time Between Pulses' (60 sec).



## Managing Fertilizer Dosing

**1** / Overview User Screen

**2** / Managing Dosing Recipes

Managing Fertilizer Dosing

**Overview User Screen**

When logged in as a technician, the Overview tab includes the following:

Verify the **Overview User** tab is selected.

**Target pH and Target EC**

Enables defining the dosing control method pH or EC (or both).

Verify the **Fertilizer Dosing** button is selected.

**Water Meter**

Displays the water flow in either of the following:

- **Nominal:** The expected flow according to the opened valves.
- **Actual:** The water flow as measured by the water meter.

**EC/pH Channel Parameters**

- **Sensor #1:** Reading of sensor #1.
- **Sensor #2:** Reading of sensor #2.
- **Average:** The average of pH sensors #1 and #2.
- **Target:** Enables defining the pH set point.
- **Control:** Enables selecting the reading will be used to control the EC/pH (can be one of the two sensors or the average of the two).

**Mixing Valve and Pre-EC**

ID	Dosing Channel	On/Off	Reaction	Level	Method	Time left min	Quantity left L	Flow rate L/h
1			No Dosing.					
2			No Dosing.					
3			No Dosing.					
4			No Dosing.					

## Overview Technician Screen

When logged in as a technician, the Overview tab includes the following:

### pH Channel Parameters

- **pH:** Enables dosing control based on pH level.
- **pH #1:** Reading of pH sensor #1.
- **pH #2:** Reading of pH sensor #2.
- **Average:** The calculated pH level based on the average of pH sensors #1 and #2.
- **pH target:** Enables defining the pH set point.
- **Control:** Enables selecting the reading will be used to control the pH level (can be one of the two sensors or the average of the two).

ID	Dosing Channel	Tank level(%)	Reaction	Nominal flow(L/h)	Calculated flow(L/h)	DM flow (L/h)	DCH on (sec)	DCH off (sec)	Act deviation(%)	Low deviation(%)	High deviation(%)	Program (%)
1	DCH1	--	EC	60.00	0.00	60.00	1.80	1800.00	0.00	30.00	40.00	--
2	DCH2	--	EC	60.00	0.00	60.00	1.80	1800.00	0.00	30.00	40.00	--
3	DCH3	--	EC	60.00	0.00	60.00	1.80	1800.00	0.00	30.00	40.00	--
4	DCH4	--	Acid	60.00	0.00	60.00	1.80	1800.00	0.00	30.00	40.00	--

### Dosing Channel Parameters

- **Tank Level (%):** Indicates the amount of fertilizer in the storage tank.
- **Reaction:** Defines the kind of reaction effecting the EC/pH control expect from the fertilizer in the tank.
  - **Passive:** Fluid that does not affects the EC/pH control.
  - **EC:** Fertilizer that will increase the EC value.
  - **Acid:** Lowers the pH.
  - **Alkaline:** Increases the pH.
- **Nominal Flow:** Dosing channel flow capacity.
- **Calculated Flow:** Actual dosing channel flow rate, as calculated by the controller.
- **DM Flow:** Flow rate measured by the dosing flow meter.
- **DCH On:** Amount of time that the dosing channel's dosing valve is on, as calculated by the controller.
- **DCH Off:** Amount of time that the dosing channel's dosing valve is off, as calculated by the controller.
- **Act Deviation (%):** Correction of the calculated dosing channel cycle time (On/Off) and programmed cycle time. It is a dynamic value calculated by the Controller.
- **Low and High Deviation (%):** Define the low and high deviation allowed during EC/pH control. In this case, the dosing ratio (proportion) can be adjusted to reach a stable value within the defined thresholds.
- **Program %:** Percentage that the valve was programmed to be open on its dosing recipe for each dosing channel.

Managing Fertilizer Dosing

## Managing Dosing Recipes

### Dosing Recipe Overview Screen

This screen displays all existing dosing recipes. Perform the following steps to manage dosing recipes:

**2. Tap the Recipes tab**

**1. Tap the Fertilizer Dosing button**

**3. Activate the relevant dosing recipes**

Inactive recipes are grayed out.

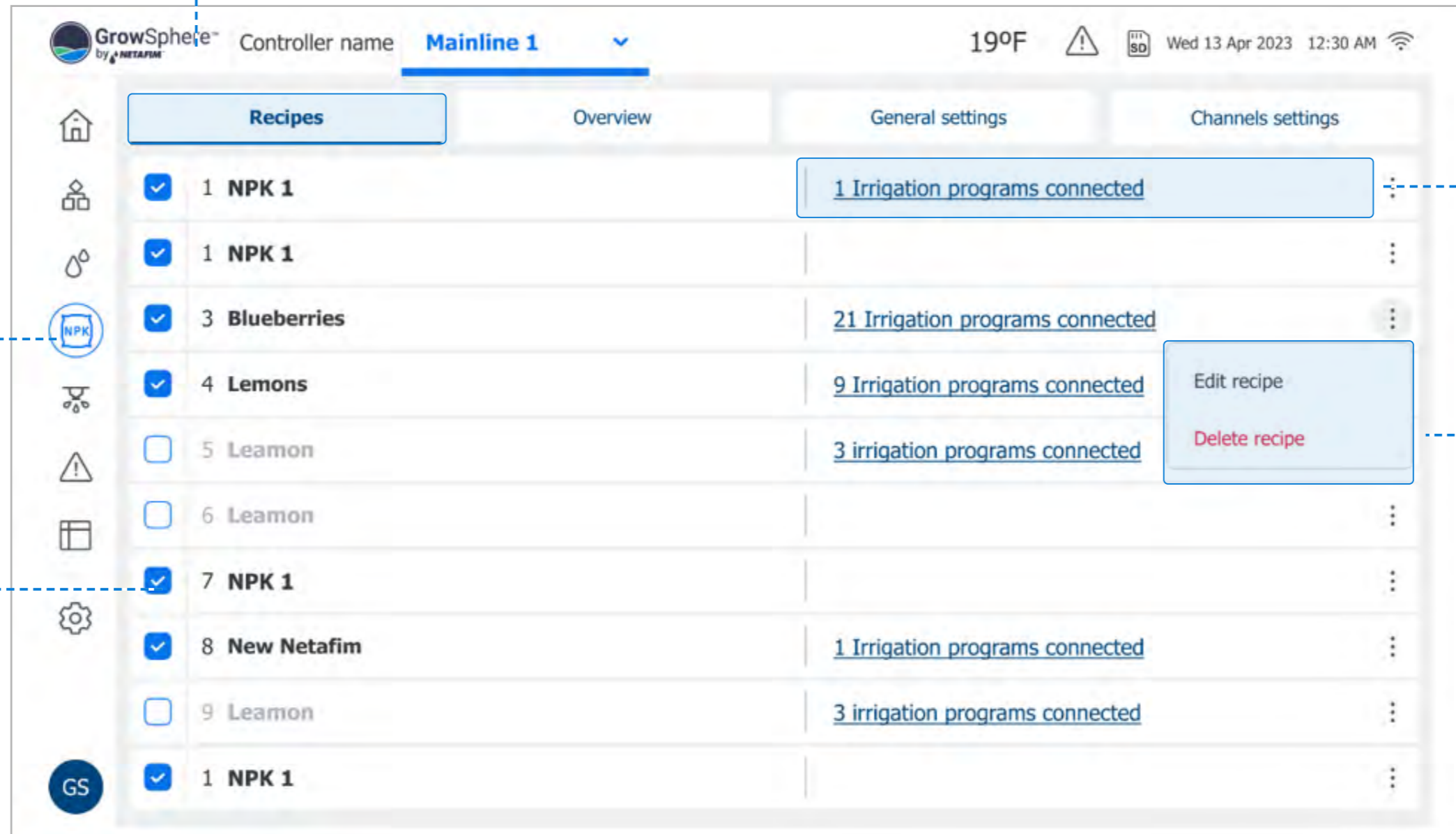

**Linked Irrigation Programs**

The number of irrigation programs a dosing recipe is connected to. An icon is displayed when a recipe is connected to at least one irrigation program.

**5. Edit Existing Dosing Recipe**

Tap the relevant recipe to edit its parameters, or tap the **Menu** button and select **Edit** (see [Configuring Dosing Recipes](#)).

**NOTE**

To create a new dosing recipe, tap the **Menu** button on the empty row and select **Edit**.

## Configuring Dosing Recipes

This screen opens when creating a new dosing recipe or editing existing one. Perform the following steps to configure dosing recipes:

Tap the **Programs linked** button to navigate to the Irrigation Dashboard.

### 3. Target EC, target pH

Displays the defined target EC/pH values.

### 4. Define the following parameters:

For each dosing channel, the following parameters can be defined.

### 1. Name the dosing recipe

The system provides a default name, but you can edit it and provide a more meaningful name.

### 2. Activate the relevant dosing channels

Active	ID	Dosing channel	Method	Quantity / Time	Value	DM control
<input checked="" type="checkbox"/>	1	Fertilizer 1	1/1000	Quantity	8.00 L	<input checked="" type="checkbox"/>
<input checked="" type="checkbox"/>	2	Fertilizer 2	1/1000	Quantity	8.00 L	<input type="checkbox"/>
<input type="checkbox"/>	3	Fertilizer 3				
<input checked="" type="checkbox"/>	4	Fertilizer 4	1/1000	Quantity	8.00 L	<input checked="" type="checkbox"/>
<input checked="" type="checkbox"/>	5	Fertilizer 5	1/1000	Quantity	8.00 L	<input checked="" type="checkbox"/>
<input type="checkbox"/>	6	Fertilizer 6				
<input type="checkbox"/>	7	Fertilizer 7				
<input type="checkbox"/>	8	Fertilizer 8				

#### • Method: Options include:

- **1/1000:** The fertilizer is injected in proportion to the water flowing in the main line. The proportion is defined using a ratio of 1 liter of fertilizer for 1000 liters of water (useful when irrigation room is very close to field).
- **Spread:** Determines amount of fertilizer to be injected during the predefined time of the irrigation.
- **Bulk:** Amount of fertilizer that will be injected constitutently during an irrigation shift. The amount can be set by time or quantity. Selected when irrigation room is far away from the field and the fertilizers are mixed with large amount of water in the distribution pipes.

The method By pulse is like a 1/1000 (proportional) but the dosing quantities are controlled by the dosing meter.

GrowSphere™ by NETAFIM Controller name Mainline 1 19°F Wed 13 Apr 2023 12:30 AM

NPK 1 Linked Programs Targets EC 0.0 pH 00.0 PRE EC 0.0

Active	ID	Dosing channel	Method	Quantity / Time	Value	DM control
<input checked="" type="checkbox"/>	1	Fertilizer 1	1/1000	Quantity	8.00 L	<input checked="" type="checkbox"/>
<input checked="" type="checkbox"/>	2	Fertilizer 2	1/1000	Quantity	8.00 L	<input type="checkbox"/>
<input type="checkbox"/>	3	Fertilizer 3				
<input checked="" type="checkbox"/>	4	Fertilizer 4	1/1000	Quantity	8.00 L	<input checked="" type="checkbox"/>
<input checked="" type="checkbox"/>	5	Fertilizer 5	1/1000	Quantity	8.00 L	<input checked="" type="checkbox"/>
<input type="checkbox"/>	6	Fertilizer 6				
<input type="checkbox"/>	7	Fertilizer 7				
<input type="checkbox"/>	8	Fertilizer 8				

## 5. Continue defining the following parameters:

- **Quantity / Time:** Options include:
  - **Quantity:** Calculates fertilizer quantity to be distributed within a specified amount of water during an irrigation shift. The Controller calculates how to spread fertilizer quantity, specified in the active dosing recipe in the amount of water of the irrigation shift.
  - **Time:** Calculates the fertilizer quantity to be distributed during an irrigation shift. The 'ON' time and 'OFF' time between pulses are calculated, and takes into account minimal ON delay-time of the dosing channel.
  - **Value:** The irrigation quantity according to the selected Method.
- **DM Control:** Defines the following alert options:
  - **On:** Provides alert of both dosing quantity and dosing flow.
  - **Off:** Provides alert of dosing flow only.

## 6.3.6 Set valves configurations

This tab shows all the Valves of this system, (up to 100 valves per mainline) for the parameters setup of each valve.

2. Select the Configuration tab

3. Select the Valves tab

1. Enter settings

	Device type	NO.	Source	Name	Flow	Area	Pump	Assigned	Module/RTU	DO
1.	Valve	1	M.Line1	BL1	20.00 m³/h	1.00 ha	station	✓	PM5052	2
2.	Valve	2	M.Line1	BL2	20.00 m³/h	1.00 ha	station	✓	PM5052	3
3.	Valve	3	M.Line1	BL3	20.00 m³/h	1.00 ha	station	✓	PM5052	4
4.	Valve	4	M.Line1	BL4	20.00 m³/h	1.00 ha	station	✓	PM5052	5
5.	Valve	5	M.Line1	BANANA1	20.00 m³/h	15.00 ha	station	✓	DO573.1	0
6.	Valve	6	M.Line1	BANANA2	20.00 m³/h	1.00 ha	station	✓	DO573.1	3

5. Define the valve parameters:

- **Device #:** Indicates the valve number.
- **Source:** Irrigation mainline to which the valve is connected.
- **Name:** Provide a descriptive name for the valve.
- **Flow (m³/h):** Set the valve's nominal flow rate.
- **Area (ha):** Define the area (in hectares) of the irrigation block allocated to the valve.
- **Assigned:** Indicates if the valve was assigned to an output module.
- **Module:** The controller module and port to which the device is connected.

**Please note:** The parameters defined in this section will be presented in your virtual farm in the Cloud and will influence the Farm management, Irrigation recommendation, and alerts accordingly.



## 6.3.7 DMS (Drain Management System) settings

GrowSphere™ by NETAFIM | CS TEST | Mainline 1 | Settings | Simulation | Wed 10 Dec 2025 14:24:49 | 82

Mainline Configuration | Control Configuration | Local I/O | Remote I/O | Communication | Wiring Diagram

Mainline | Sub-Mainlines | Pump Station | Filter Station | Dosing Station | Cool & Mist | Valves | DMS | Other Devices

Mainline

Valves: 6

<input checked="" type="checkbox"/> Pump Station	<input checked="" type="checkbox"/> Sub-Mainlines
<input checked="" type="checkbox"/> Filter Station	<input type="checkbox"/> External Filter Station
<input checked="" type="checkbox"/> Dosing Station	<input checked="" type="radio"/> Local <input type="radio"/> Remote
<input checked="" type="checkbox"/> Cooling & Misting	
<input checked="" type="checkbox"/> Main Valve	<input checked="" type="checkbox"/> Main WM <input type="radio"/> Local <input type="radio"/> Pump station
<input checked="" type="checkbox"/> Drain Management System	
<input checked="" type="checkbox"/> Main Pressure sensor	<input type="radio"/> After filter <input type="radio"/> Local

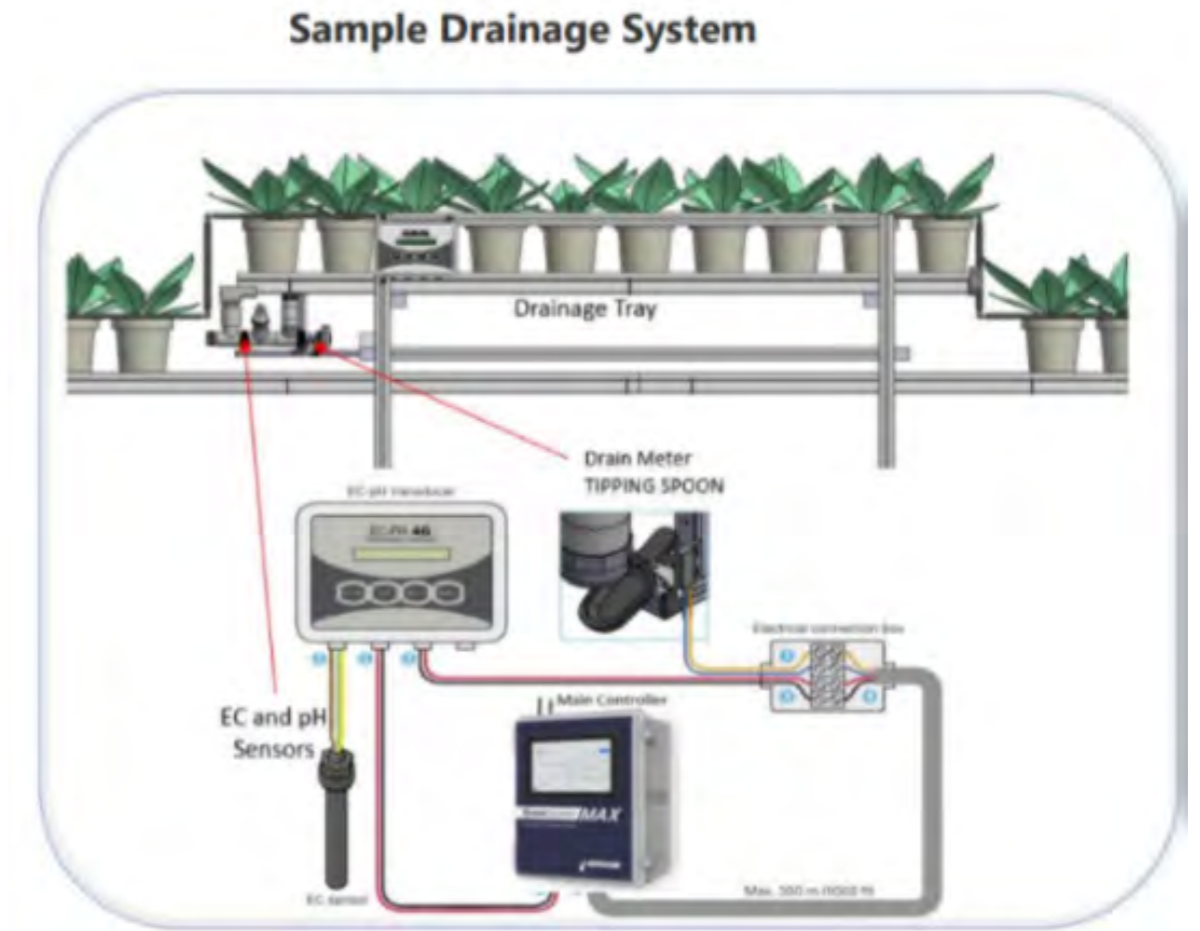

## Setting the DMS

GrowSphere™ by NETAFIM CS TEST **Mainline 1** Settings Simulation Wed 10 Dec 2025 14:25:50

Mainline Configuration Control Configuration Local I/O Remote I/O Communication Wiring Diagram

Mainline Sub-Mainlines Pump Station Filter Station Dosing Station Cool & Mist Valves **DMS** Other Devices

Number of DMS trays: 8

Number of irrigations before no drain alert: 3

On delay: 01:00 mm:ss

Off delay: 00:30 mm:ss

DMS	1	2	3	4	5	6	7	8
Active	<input checked="" type="checkbox"/>	<input checked="" type="checkbox"/>	<input checked="" type="checkbox"/>	<input checked="" type="checkbox"/>	<input checked="" type="checkbox"/>	<input checked="" type="checkbox"/>	<input checked="" type="checkbox"/>	<input checked="" type="checkbox"/>
Dosing meter	<input checked="" type="checkbox"/>	<input checked="" type="checkbox"/>	<input checked="" type="checkbox"/>	<input checked="" type="checkbox"/>	<input checked="" type="checkbox"/>	<input checked="" type="checkbox"/>	<input checked="" type="checkbox"/>	<input checked="" type="checkbox"/>
EC	<input type="checkbox"/>	<input type="checkbox"/>	<input type="checkbox"/>	<input type="checkbox"/>	<input type="checkbox"/>	<input type="checkbox"/>	<input type="checkbox"/>	<input type="checkbox"/>
pH	<input type="checkbox"/>	<input type="checkbox"/>	<input type="checkbox"/>	<input type="checkbox"/>	<input type="checkbox"/>	<input type="checkbox"/>	<input type="checkbox"/>	<input type="checkbox"/>
Number of drippers	5	5	0	0	0	0	0	0
Dripper flow rate	10.0 L/h	12.0 L/h	0.0 L/h	0.0 L/h	0.0 L/h	0.0 L/h	0.0 L/h	0.0 L/h
Valve	1	2	0	0	0	0	0	0

Number of DMS trays

On Delay

to start accumulation for irrigation event

Active Check/Uncheck

Dosing/DMS Meter Yes/No

EC/pH Yes/No

Number of drippers  
calculate the drainage %

Number of drippers × Dripper Flow rate = calculate the drainage %

Valve (Number) assigned to the DMS tray

Number of irrigations before "no drain" alert

Off Delay

To stop accumulation for irrigation event



## DMS IO allocation

### Drain Meter (Spoon) Digital Input

Select device ✕

Main & Sub line    **Dosing**    P. station & Reservoir    Filters    Others    Monitor - 0/100

Dosing Booster Protection (1)	Dosing Meter (0)	Drain Meter (0)	Dosing Pressure Switch (0)
Pre EC tank low level (2)	Fertilizer Tank Low Level (3)	Pre EC Tank WM (2)	

### EC and pH drain analogue inputs.

Select device ✕

Main & Sub line    **Dosing**    P. station & Reservoir    Filters    Crop sensors    Others    Monitor - 0/100

EC (1)	pH (1)	EC Verify (0)	pH Verify (0)
EC Pre-Control (1)	EC Drain (0)	Pre Ec Tank level (2)	Fertilizer Tank level (4)
PH Drain (0)			



## DMS Alerts

GrowSphere™ by NETAFIM CS TEST Mainline 1 Alerts Simulation Wed 10 Dec 2025 14:53:10 97

Active Alerts History Alerts Alerts Settings

Mainline Controller

Pump Station	Filter Station
Mainline + Sub-Mainlines	Dosing Station
Dosing channel	Mixing valve
<b>Drain Measuring System</b>	Cooling / Misting

GrowSphere™ by NETAFIM CS TEST Mainline 1 Alerts Simulation Wed 10 Dec 2025 14:53:41 96

← Drain Measuring System

Description	Value	Delay	Action	sms	Output	Critical Value	Delay	Action	sms	Output
DMS Low EC	40	60s	Alert Only	<input type="checkbox"/>	<input type="checkbox"/>	50	120s	Alert Only	<input type="checkbox"/>	<input type="checkbox"/>
DMS High EC	40	60s	Alert Only	<input type="checkbox"/>	<input type="checkbox"/>	45	120s	Alert Only	<input type="checkbox"/>	<input type="checkbox"/>
DMS Low PH	40	60s	Alert Only	<input type="checkbox"/>	<input type="checkbox"/>	45	120s	Alert Only	<input type="checkbox"/>	<input type="checkbox"/>
DMS High PH	40	60s	Alert Only	<input type="checkbox"/>	<input type="checkbox"/>	45	120s	Alert Only	<input type="checkbox"/>	<input type="checkbox"/>
DMS Low Drain	40%	60s	Alert Only	<input type="checkbox"/>	<input type="checkbox"/>	50%	120s	Alert Only	<input type="checkbox"/>	<input type="checkbox"/>
DMS High Drain	40 %	60s	Alert Only	<input type="checkbox"/>	<input type="checkbox"/>	50 %	120s	Alert Only	<input type="checkbox"/>	<input type="checkbox"/>
DMS No Drain		60s	Alert Only	<input type="checkbox"/>	<input type="checkbox"/>		120s	Alert Only	<input type="checkbox"/>	<input type="checkbox"/>



# DMS Logs

The screenshot shows the GrowSphere MAX user interface. The top navigation bar includes sections for WARRANTY & SAFETY, QUICK START, INTRODUCTION, INSTALLATION, **CONTROLLER CONFIGURATION**, CONTROLLER OPERATION, MISTING, COOLING & HUMIDIFICATION, DOSING, CONDITIONS & TRIGGERS, MIXING VALVES + PRE-EC, and REMOTE UNITS. The main interface displays a sidebar menu with options like Mainline, Irrigation, Accumulation, Filter, Events, and Drain Accumulation (highlighted in red). Two overlapping windows show the 'DMS Daily Logs' for 09.12.2025. The top window shows a table with columns for Date, Time, Name, Valve, Irrig Qty, Irrig Duration, Drain Qty, and Drain %. The bottom window shows a similar table with additional columns for Irrig EC Avg, Irrig pH Avg, Drain EC Avg, and Drain pH Avg.

Date	Time	Name	Valve	Irrig Qty, m <sup>3</sup>	Irrig Duration	Drain Qty, m <sup>3</sup>	Drain %
09.12.2025	23:56:59	DMS1.2	BL2	90.02	01:30:01	0	0
09.12.2025	23:56:59	DMS1.1	BL1	75	01:30:01	0	0

Date	Time	Irrig Qty, m <sup>3</sup>	Drain %	Irrig EC Avg	Irrig pH Avg	Drain EC Avg	Drain pH Avg
09.12.2025	23:56:59	90.02	0	3.79	24.4	0	0
09.12.2025	23:56:59	75	0	3.79	24.4	0	0



## 6.3.8 Configuring Other Devices

This tab shows all the Valves of this system, (up to 256 valves per mainline) for the parameters setup of each valve.

2. Select the Configuration tab

3. Select the Other devices tab

1. Tap the Configuration tab

	Device type	NO.	Source	Name	Flow	Assigned	Module/RTU	DO
1.	MainValve	1	M.Line1	MVLV1.1	—	✓	PM5052	1
2.	Filter	1	M.Line1	FLTR1.1	—			
3.	DosingChannel	1	D.Statio1	DCH1.1	600.00 L/h	✓	DO573.1	6
4.	DosingChannel	2	M.Line1		600.00 L/h			
5.	DosingChannel	3	D.Statio1	DCH1.3	600.00 L/h	✓	DO573.1	8
6.	DosingChannel	4	D.Statio1	DCH1.4	600.00 L/h	✓	DO573.1	9
7.	DosingChannel	5	M.Line1	DCH1.5	50.00 L/h			
8.	BoostPump	1	D.Station1	BPMP1.1	—	✓	DO573.1	4

5. Define the device parameters:

- **Device Type:** Indicates the device type.
- **Device #:** Indicates the device number.
- **Source:** The source to which the device is connected.
- **Name:** Provide a descriptive name for the valve.
- **Flow:** Device's nominal flow rate.
- **Module and DO:** The controller module and port to which the device is connected.

This field is not editable here. "V" means the valve is active and has an output assigned. Gray indicates it's inactive. Use this to set valves that will be added later physically.



## 6.3.9 Configuring Reservoir/well

Reservoir / well management

- Reservoir/well control Level
- Level Switch minimal and maximal.
- Analogue level sensor
- Re-fill management logic
- Logs of reservoir/well activity.
- Remote sources control by radio RTU
- Pump / well control.
- Multiple pumps logic control.
- Pump protection Switch / OL
- Water meter
- Pressure Sensor

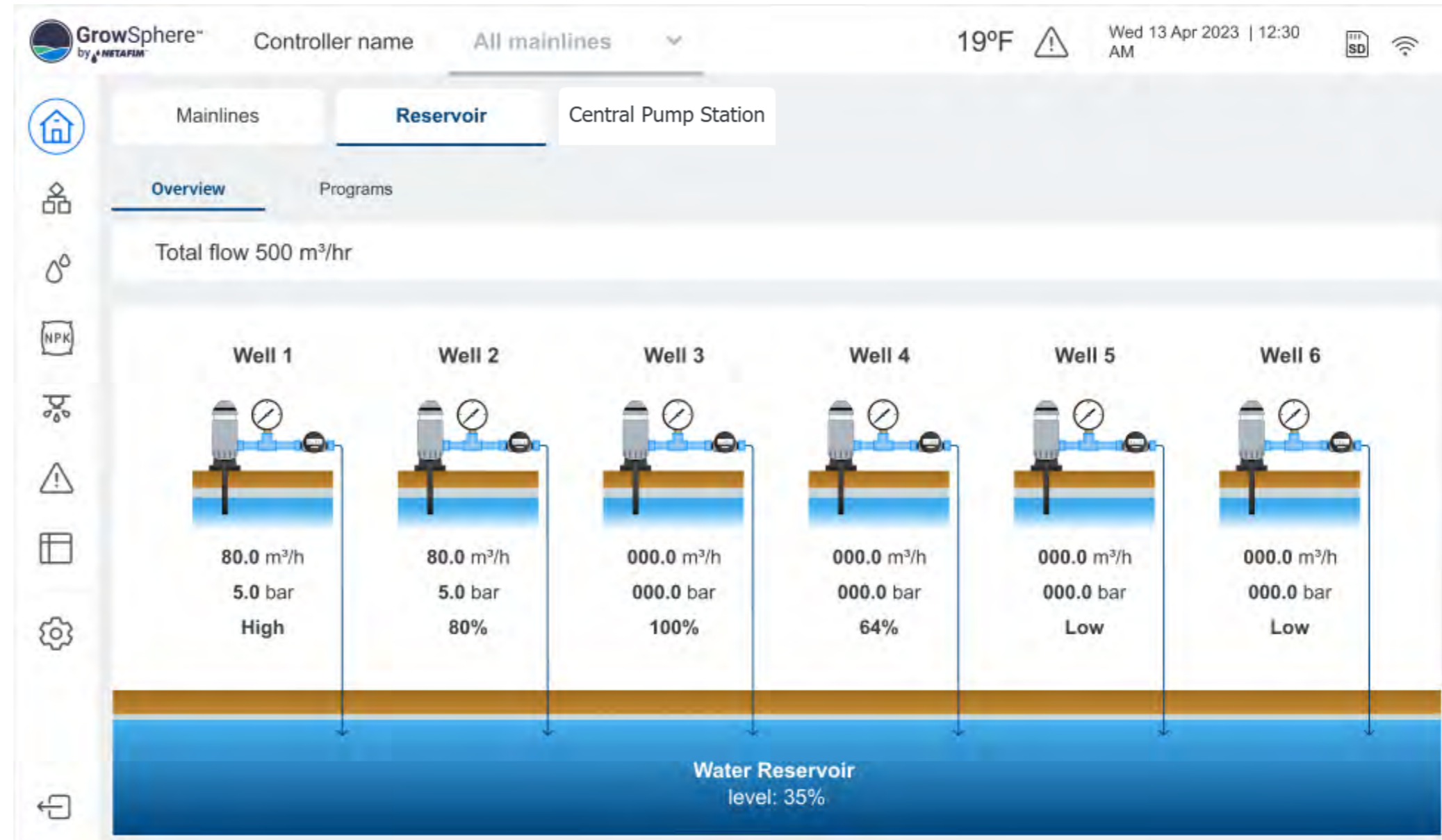

## 1. Control configuration

GrowSphere™ by NETAFIM

CS TEST Mainline 2 Settings Simulation Sun 27 Jul 2025 14:45:39

Mainline Configuration **Control Configuration** Local I/O Remote I/O Communication Wiring Diagram

Reservoir & Wells Central pump station

Reservoir

Reservoir  Level Analog  Emergency high level

Wells

Number of Wells 3

Well 1  Level Analog

Well 2  Level Analog

Well 3  Level Analog

## 2. Define the reservoir and its wells, up to 6 wells can be configured.

Reservoir options:

- Enable reservoir
- Define level sensor analog or digital
- Enable emergency high level

Wells options:

- Set the number of wells
- Define the level sensor, analog or digital



## 6.3.10 Central Pump Operation Options

The Central Pump Station serves all four mainlines.

It is not possible to combine or mix Mainline Pump Station and Central Pump Station configurations.

### ON/OFF

The MAX send DO to the CPS controller (VFD) If the VFD has signal from the MAX, the CPS will keep working. The CPS will work according to its VFD settings.

The screenshot displays the GrowSphere MAX Controller Configuration interface. The top navigation bar includes 'GrowSphere™ by NETAFIM', 'CS TEST', 'All Mainlines' (with a dropdown arrow), 'Settings', 'Simulation', a warning icon, a user icon 'SD', and the date/time 'Sun 14 Dec 2025 11:41:16'. Below the navigation bar, there are tabs for 'Mainline Configuration', 'Control Configuration' (which is active), 'Local I/O', 'Remote I/O', 'Communication', and 'Wiring Diagram'. Under 'Control Configuration', there is a sub-tab for 'Reservoir & Wells' and 'Central pump station'. The 'Central pump station' section is checked with a blue checkbox. Below this, there are four radio button options: 'ON / OFF' (which is selected), 'Flow set points', 'Pressure set points', and 'Pump Management'. A vertical sidebar on the left contains various system icons, including a gear icon for settings.



## Flow set points

The MAX will calculate the flow summaries of all the mainlines that are irrigating. According to the calculated flow, the relevant set point/DO will be sent. This DO will be a DI in the VFD side which will operate the relevant pumps.

The screenshot shows the 'GrowSphere™ by NETAFIM' interface. The top navigation bar includes 'CS TEST', 'All Mainlines', 'Settings', 'Simulation', a warning icon, a date/time display 'Sun 14 Dec 2025 11:40:20', and a signal strength icon. The main menu on the left includes icons for Home, Reservoir & Wells, NPK, and Settings. The 'Control Configuration' tab is active, with sub-tabs for 'Local I/O', 'Remote I/O', 'Communication', and 'Wiring Diagram'. Under 'Reservoir & Wells', the 'Central pump station' is selected. The configuration options are:
 

- Central pump station
- ON / OFF
- Flow set points
- Pressure set points
- Pump Management

 A table below shows the 'Maximal flow (m³/h)' for four mainlines:
 

Nr.	Maximal flow (m³/h)
1	105.0
2	100.0
3	0.0
4	0.0



### Pressure set points

For each mainline of the MAX it will have its nominal pressures. The set point pressure will attach to DO. This DO will be a DI in the VFD side which will operate the relevant pumps.

The screenshot shows the GrowSphere MAX Controller Configuration interface. The 'Control Configuration' tab is active, and the 'Central pump station' is selected. The 'Pressure set points' option is chosen among 'ON / OFF', 'Flow set points', and 'Pump Management'. A table below shows the nominal pressures for four mainlines (M.line 1 to 4).

M.line	Nominal pressure (Bar)
1	3.0
2	5.0
3	0.0
4	0.0



## Pump management

MAX will fully operate the CPS, as it is doing today, but it will be managed as control level and not mainline level.

Up to 8 pumps can be managed per controller.

The screenshot shows the GrowSphere MAX Controller Configuration interface. The top navigation bar includes 'CS TEST', 'All Mainlines', 'Settings', 'Simulation', and a date/time display. The main menu on the left includes 'Mainline Configuration', 'Control Configuration', 'Local I/O', 'Remote I/O', 'Communication', and 'Wiring Diagram'. The 'Control Configuration' section is active, showing 'Reservoir & Wells' and 'Central pump station'. The 'Central pump station' is checked. The 'Pump Management' tab is selected, showing 'ON / OFF', 'Flow set points', 'Pressure set points', and 'Pump Management' options. The 'Pumps' field is set to 3. The 'Inlet pressure sensor' is checked, and the 'Min pressure (Bar)' is set to 1.0. A table below shows settings for three pumps:

Pump	1	2	3
Overload	<input type="checkbox"/>	<input type="checkbox"/>	<input type="checkbox"/>
Inlet pressure switch	<input type="checkbox"/>	<input type="checkbox"/>	<input type="checkbox"/>
Water meter	<input checked="" type="checkbox"/>	<input checked="" type="checkbox"/>	<input checked="" type="checkbox"/>
Maximal flow	50.0	50.0	50.0



## Central Pump Station – Local IO

### DO allocation

Select device ✕

Main & Sub line      Dosing      **P. station & Reservoir**      Filters      Others

Well Pump (2)	CPS Pump (0)	CPS flow SP (0)	CPS pressure SP (0)
CPS ON/OFF (0)			

### AI allocation

Select device ✕

Main & Sub line      Dosing      **P. station & Reservoir**      Filters      Crop sensors      Others      Monitor - 0/100

Well level sensor (3)	Well Pressure sensor (3)	Reservoir level sensor (1)	CPS Outlet Pressure (0)
CPS Inlet Pressure (0)	CPS Pump In Pressure (0)		

### DI allocation

Select device ✕

Main & Sub line      Dosing      **P. station & Reservoir**      Filters      Others      Monitor - 0/100

Well Watermeter (1)	Well Pump protection (3)	Reservoir max level (0)	Reservoir low level (0)
Reservoir Emerg. high (0)	Reservoir Emerg. low (1)	Well Low Level switch (0)	Well High Level switch (0)
CPS outlet WM (0)	CPS inlet switch (0)	CPS pump WM (0)	CPS pump OL (0)
CPS pump switch (0)	CPS non critical alert (0)	CPS critical alert (0)	



## Central Pump Station – SCADA

The image displays three overlapping screenshots of the GrowSphere SCADA interface for a Central Pump Station, illustrating different operational states:

- Top Left Screenshot (Normal Operation):** Shows the 'Central Pump Station' tab selected. The status bar indicates 'Simulation' and 'Sun 14 Dec 2025 14:44:01'. The main display shows 'Flow set points - 100.0 m³/h' with 'Outlet flow' at 0.0 m³/h and 'Outlet pressure' at 0.0 Bar. A blue dashed arrow points to the top right corner with the text: "On/Off or flow/pressure trigger control. Normal operation mode."
- Middle Screenshot (Fault Operation):** Shows the same interface but with a red warning icon in the status bar and a red banner that reads "Station Low Pressure". A blue dashed arrow points to the top right corner with the text: "On/Off or flow/pressure trigger control. Fault operation mode."
- Bottom Right Screenshot (Management Mode):** Shows a detailed schematic of the pump station with three pumps labeled 1, 2, and 3. The status bar shows a red warning icon and the time 'Sun 14 Dec 2025 15:42:11'. A blue dashed arrow points to the top right corner with the text: "SCADA in Management mode".



## Central Pump Station – Alerts

GrowSphere™ by NETAFIM CS TEST All Mainlines Alerts Simulation Sun 14 Dec 2025 15:01:42

Active Alerts History Alerts Alerts Settings

Mainline **Controller**

Disable All Alerts

Alarms auto reset delay (hh:mm) 00:01  Auto resume ML after alerts reset

System

Reservoir & wells

**Central pump station**

Remote System

GrowSphere™ by NETAFIM CS TEST All Mainlines Alerts Simulation Sun 14 Dec 2025 15:02:31

Central Pump Station

Description	Value	Delay	Action	sms	Output	Critical Value	Delay	Action	sms	Output
Station Low Pressure	1	600s	Alert Only	<input type="checkbox"/>	<input type="checkbox"/>	1	1200s	Alert Only	<input type="checkbox"/>	<input type="checkbox"/>
Station High Pressure	1	600s	Alert Only	<input type="checkbox"/>	<input type="checkbox"/>	1	1200s	Alert Only	<input type="checkbox"/>	<input type="checkbox"/>
VFD Non-Critical Alert		60s	Alert Only	<input type="checkbox"/>	<input type="checkbox"/>		120s	Alert Only	<input type="checkbox"/>	<input type="checkbox"/>
VFD Critical Alert		60s	Alert Only	<input type="checkbox"/>	<input type="checkbox"/>		120s	Alert Only	<input type="checkbox"/>	<input type="checkbox"/>



## Central Pump Station – Logs

GrowSphere™ by NETAFIM CS TEST All Mainlines Reports Simulation Sun 14 Dec 2025 15:03:51

- Mainline
- Controller
- Reservoir & wells
- Central pump station
- Central pump Daily accumulation
- Weather Station
- Alerts History
- Energy meters accumulation

GrowSphere™ by NETAFIM CS TEST Mainline 1 Reports Simulation Sun 14 Dec 2025 15:04:58

Central pump events log 14.12.2025 Refresh page 1 of page 1

Name	Start date	Time	Start/Stop
Pump station	14.12.2025	12:07:33	Start
Pump station	14.12.2025	12:06:42	Stop
Pump station	14.12.2025	11:58:40	Start

GrowSphere™ by NETAFIM CS TEST Mainline 1 Reports Simulation Wed 24 Dec 2025 13:28:31

Daily accumulation 22.12.2025 Refresh page 1 of page 1

Name	Qty (m³)	Time
Pump 3	0	00:00:00
Pump 2	0	00:00:00
Pump 1	0	00:00:00
Pump station	0	00:00:00



## 6.3.11 Define the Local I/O

### Digital output

In Local/Remote I/O digital outputs, define the pump wells.

Pumps can be connected via radio.

In Local/Remote I/O digital Inputs, define the relevant devices.

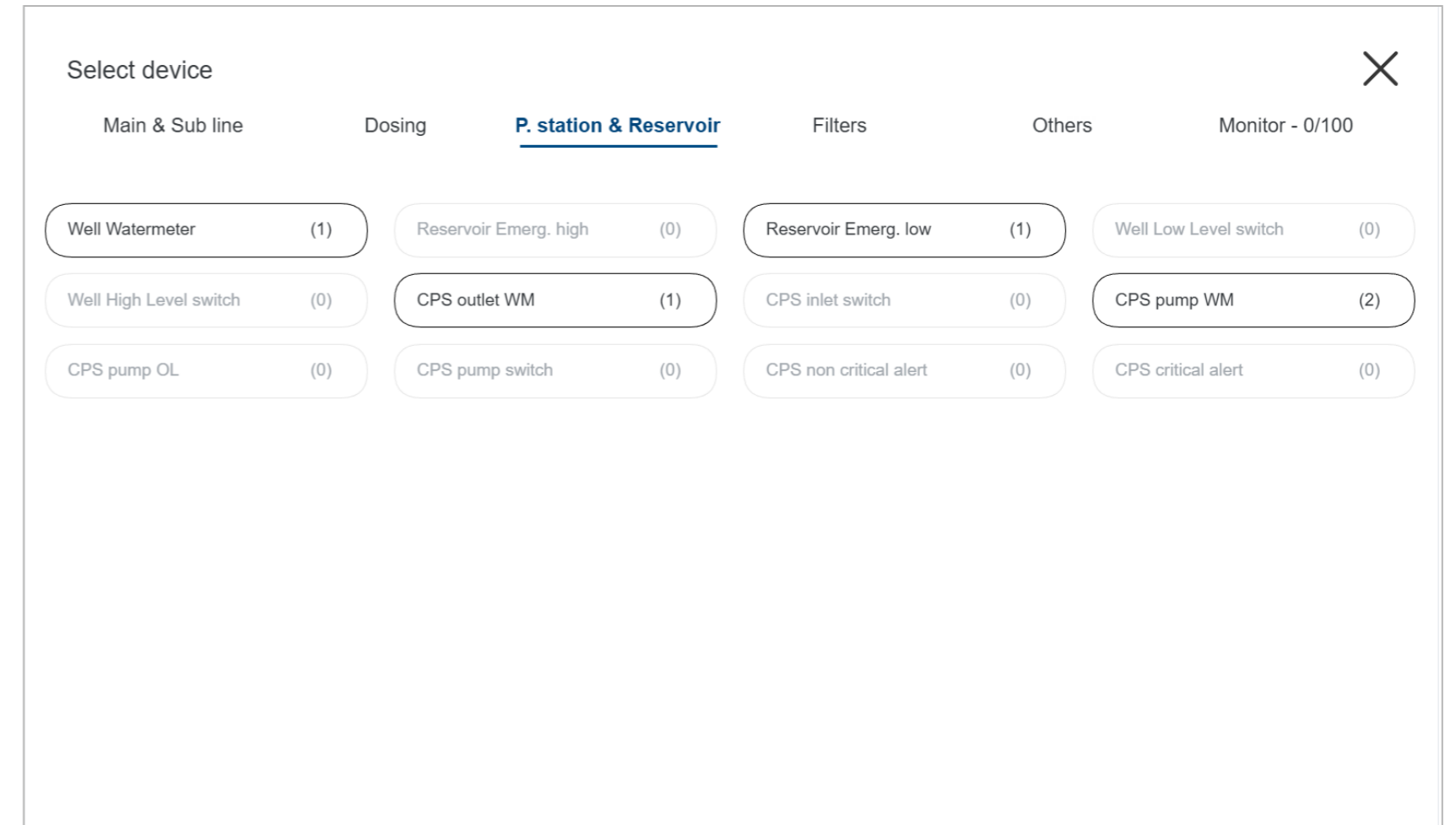
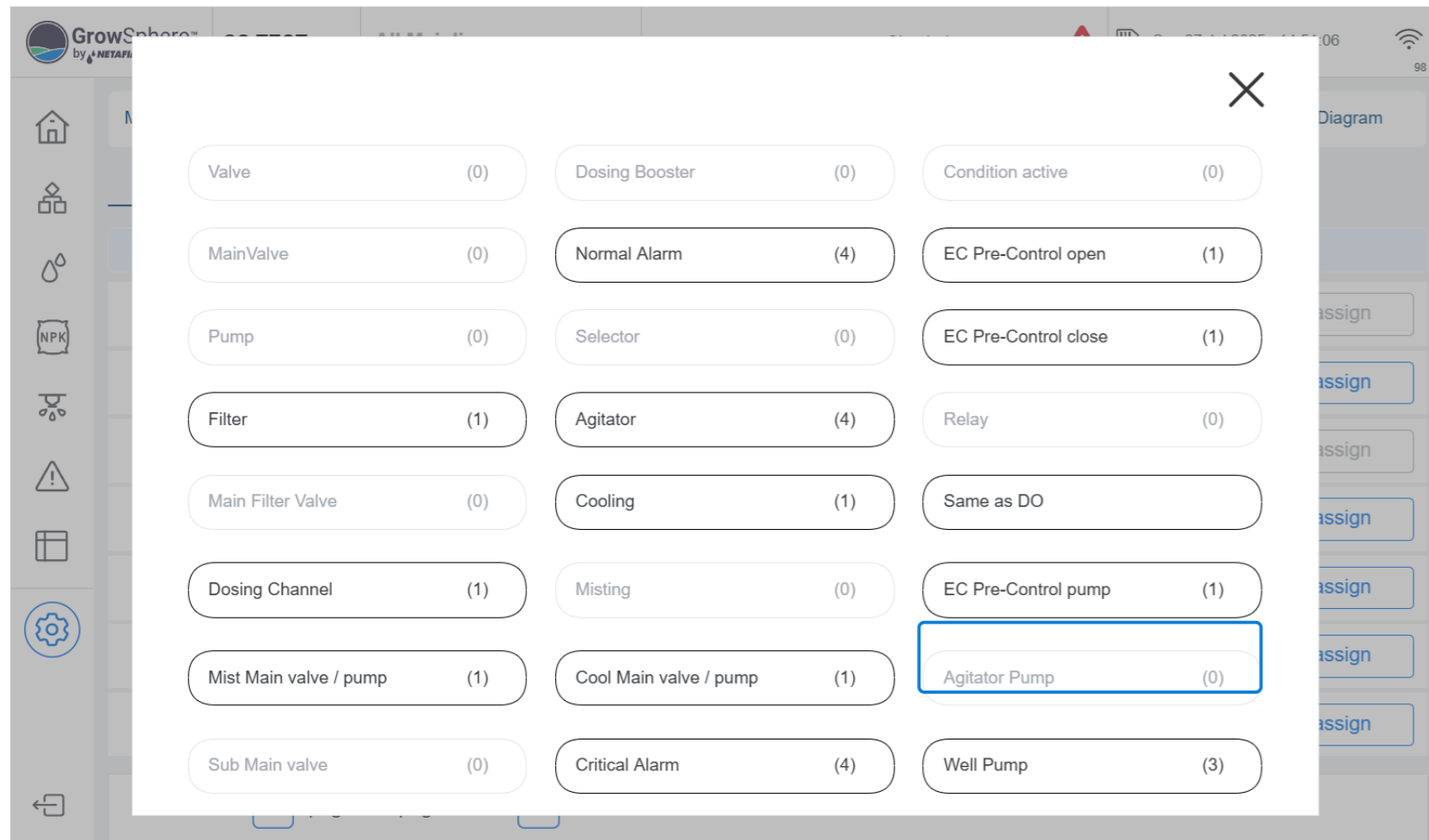

## Analogue output

In Local/Remote I/O digital Inputs, define the relevant devices.

GrowSphere™ by NETAFIM CS TEST All Mainlines Settings Simulation Sun 21 Dec 2025 16:14:47

Mainline Configuration Control Configuration **Local I/O** Remote I/O Communication Wiring Diagram

Local digital output Local digital input **Local analog input**

Module	AI	Device type	NO.	Source	Name	Input	Unit	Assigned
3.	AI561.1 2	Radiation	2	System	Rad2	4 - 20 mA		Unassign
Input Range (mA)		Output Range		Offset		<b>Actual</b>		
4 - 20		= 0 - 1500		0.00		-375.03 W/m²		
4.	AI561.1 3	CPS Inlet Pressure	1	CPS	CommP1	4 - 20 mA		Unassign
Input Range (mA)		Output Range		Offset		<b>Actual</b>		
4 - 20		= 0 - 100		0.00		-25.00 Bar		

page 2 of page 2

Select device

Main & Sub line Dosing **P. station & Reservoir** Filters Crop sensors Others Monitor - 0/100

Well level sensor (1) Well Pressure sensor (3) Reservoir level sensor (0) CPS Outlet Pressure (0)

CPS Inlet Pressure (0) CPS Pump In Pressure (0)



## Monitor the reservoir/wells

**2. Reservoir tab**

**1. Home tab**

**3. Overview: view the reservoir and Pump well status**

The screenshot shows the GrowSphere MAX user interface. At the top, there is a navigation bar with 'All Mainlines' selected. Below this, there are tabs for 'Mainlines', 'Reservoir', and 'Central Pump Station'. The 'Reservoir' tab is active, showing an 'Overview' section. The overview displays 'Total flow 0.0 m³/h' and three wells: Well 1, Well 2, and Well 3. Each well shows a flow rate of 0.0 m³/h and a pressure of 0.0 Bar. Below the wells, there are 'High' and 'Low' status indicators. At the bottom, a 'Water Reservoir level 0%' is displayed. On the left side, there is a vertical navigation menu with icons for Home, Overview, Programs, and various system components. The top right corner shows 'Simulation' mode, a warning icon, and the date/time 'Sun 27 Jul 2025 17:06:06'.



## Well pump programs

- 1. Home tab** -----
- 2. Reservoir tab** -----
- 3. Programs:** -----  
define the activity schedule for each of the pumps.
- Activation by:
- Time or level sensor
  - Level sensor, can be digital or analogue
  - Set the percentage or time
  - Day of the week
  - Operation window for the Level activation
  - Priority between the pumps.
  - Rotation between the pumps.
  - On/Off delays
  - SOS high level alarm to stop all wells

The screenshot shows the GrowSphere MAX Controller Configuration interface. The top navigation bar includes 'Home', 'Simulation', and a date/time display. The main content area is divided into 'Mainlines', 'Reservoir', and 'Central Pump Station' sections. The 'Reservoir' section is active, showing a 'Programs' table with the following data:

Remote well	Trigger type	start at	stop at	Operation week days	Operation window start	Operation window stop	Priority
1	Level	25%	90%	S M T W T F S	06:00	16:00	1
2	Time	08:00	12:00	S M T W T F S	--	--	2
3	Level	25%	90%	S M T W T F S	16:00	06:00	1

At the bottom of the interface, there are settings for 'Rotation' (00:10), 'Start ON delay' (00:10), 'Start OFF delay', and 'SOS high level - stop all wells' (checked).



## Digital Outputs

1. Click assign for each row to assign
2. From the pop up window select the desired output
3. Define the Flow and irrigated area for each valve
4. The I/O module to which the device has been assigned to can be selected by skip between pages 1- 5

Module	DO	Device type	NO.	Source	Name	Flow	Area	Assigned
DO573.1	8	Dosing Channel	3	D.Statio1	DCH1.3	50.00 L/h	—	Unassign
DO573.1	9	Dosing Channel	4	D.Statio1	DCH1.4	600.00 L/h	—	Unassign
DO573.1	10	Pump	1	M.Line2	PMP2.1	70.00 m³/h	—	Unassign
DO573.1	11	MainValve	1	M.Line2	MVLV2.1	—	—	Unassign
DO573.1	12	Sub Main valve	1	M.Line2	SUBMV2.1	—	—	Unassign
DO573.1	13	Sub Main valve	2	M.Line2	SUBMV2.2	—	—	Unassign
DO573.1	14	Assign	0			—	—	Unassign

**Assign:** By clicking Assign, the system will indicate how many devices are not yet assigned, and will automatically assign it to the next available port

## Dosing valves should be assigned on the D0572 Module



## Analog Inputs

Perform the following steps to configure all local analog inputs (i.e., sensors):

1. When you click on Assign, a list of devices that have been allocated will appear.  
From there, you can choose the sensor you want to work with and set the input ranges, name, and offset for each sensor
2. To assign additional analog sensors, navigate between the pages

The screenshot shows the 'Local I/O' configuration page. The table below represents the data visible in the interface:

Module	AI	Device type	NO.	Source	Name	Input	Unit	Assigned
AI561.1 2		Fertilizer Tank level	1	M.Line2	FRTL2.1	4 - 20 mA		Unassign
AI561.1 3			0			4 - 20 mA		Unassign

**Assign:** By clicking on Assign, a pop up window open with the available options. The allocated devices are presented in there.



### 6.3.12 View the wiring diagram

The wiring diagram shows the module and port for each device that has been assigned. You can follow the diagram to connect the devices properly.

3. Tap the Wiring Diagram tab

1. Tap the Configuration tab

2. Select Settings and type your credentials

The screenshot shows the GrowSphere MAX Controller Configuration interface. At the top, there are navigation tabs: Configuration, Local I/O, Remote I/O, Communication, and Wiring Diagram. The Wiring Diagram tab is highlighted. Below the tabs, there are four columns of I/O modules:

- PM-5052 - CPU:** Lists various input/output points like WM1, POL, DMTR1.1, DMTR1.2, DMTR1.3, DMTR1.4, IO1 through IO7.
- DO-573 - Output:** Lists output points like vlv4 through vlv8, AGTR1.1 through AGTR1.4, AGPMP1.1, and Common points.
- DO-572 - Output:** Lists output points like DCH1.1 through DCH1.4 and Common points.
- AI-561 - Analog Input:** Lists analog input points like EC1.1, PH1.1, Rad, and Temp.out.

A settings menu is open over the Configuration tab, showing 'Settings' selected. The menu also includes 'Preferences' and 'Admin'.



## 6.3.13 Mainline External Pause

### / Definition

The mainline external pause is command to pause the mainline when the Digital Input is active. Each mainline has its own external pause Digital Input. The purpose of the mainline external pause is to permit the user to pause the mainline by an emergency push switch when it is an emergency and need to pause immediately the mainline operation. The mainline will be paused all the time that the switch (DI) is active.

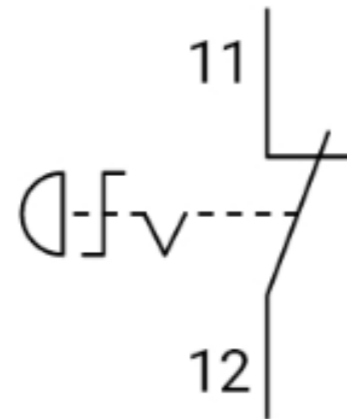

### / Digital input

The **GrowSphere™ Max** has an option to select a digital input named:

- ML1 External pause
- ML2 External pause
- ML3 External pause
- ML4 External pause

Each mainline will have an option to select a mainline external pause.

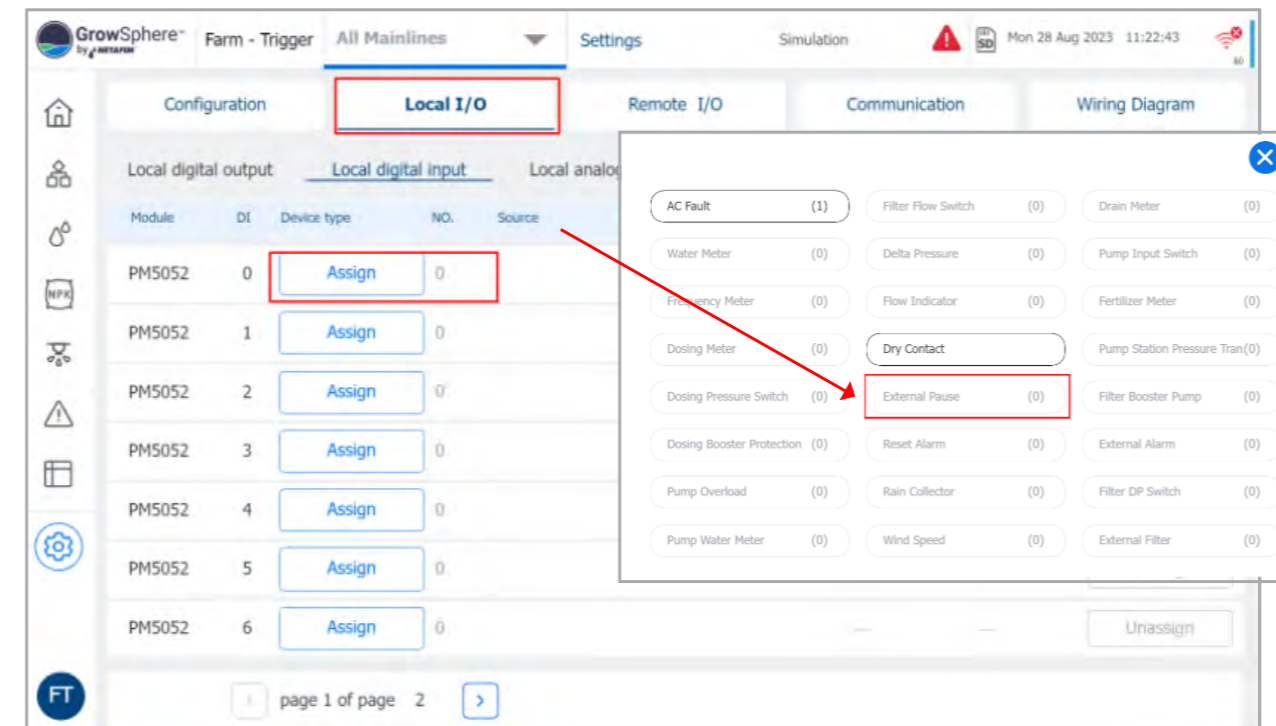

## / External pause logic

The mainline external pause is active when:

- When the digital input is selected N.O. then when the input is close then will be active.
- When the digital input is selected N.C. then when the input is open then will be active.
- Fix delay: the External pause digital input have a fix delay of 5 seconds for ON and Off delay. See the following graph.

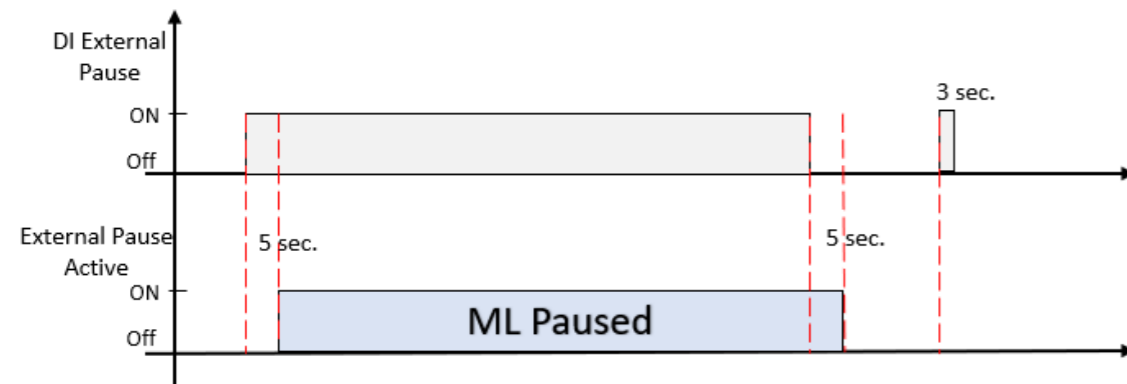

## Pause Mainline

The action of this active mainline pause is similar to the manual pause mainline command.

### ⚠ External pause

The Scada will show the message External pause when it is paused by the external pause switch. "External pause".

- When the mainline it is paused by the External it can be canceled only by an unactive DI.
- When the user would like to use only one External pause switch to pause all the mainlines, then will wire the Switch in parallel to the mainline Di selected for each mainline.
- Example of connection one External pause switch to 4 Mainlines.

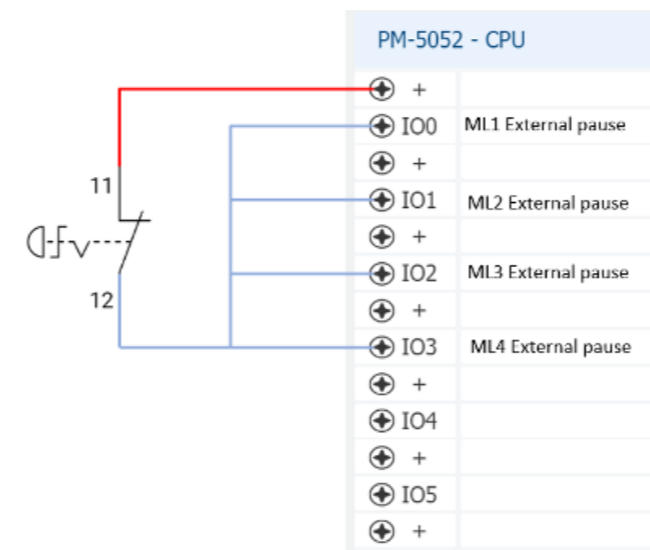

## 6.4 GrowSphere™ Max Alerts

The Alerts section's tabs are: All Mainlines tab or each Mainline tab.

When the alerts are affecting all the main lines then only the Mainlines tab will be active.

The alerts are divided on 3 sections.

- **Active Alerts**
- **History Alerts**
- **Alerts Settings**

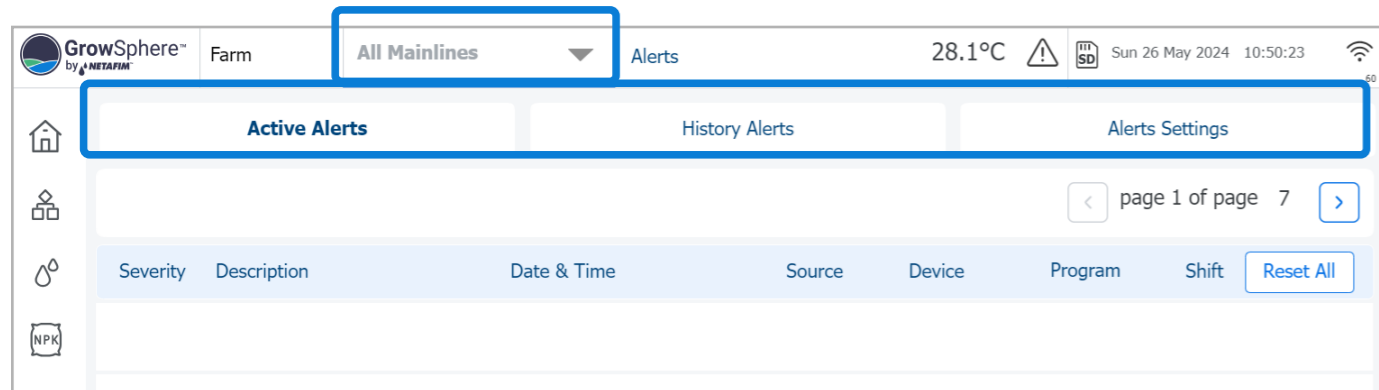

## 6.4.1 Viewing Active Alerts

Active alerts includes all alerts that are currently active and alerts that were activated and were not reset. Perform the following steps to view information about currently active alerts:

### Active alert icon

The Active Alerts tab can be accessed from any screen by clicking the Alert button at the top of the screen.

### 2. Tap the Active Alerts tab

### 1. Tap the Alerts button

Severity	Description	Date & Time	Source	Device	Program	Shift	Reset All
	Maximal flow	01.01.23   13:00 PM	M.line 1	22. Valve	2. Tomato...	4	Reset
	Base station disconnected	01.01.23   13:00 PM	M.line 1	Remote Units	2. Tomato...	4	Reset
	Low level tank number	01.01.23   13:00 PM	Dosing	5. Tank	2. Tomato...	4	Reset
	Radio net host disconnected	01.01.23   13:00 PM	M.line 1	4. Channel 1	2. Tomato...	4	Reset
	Dosing uncontrol flow	01.01.23   13:00 PM	Dosing	3. Pump	2. Tomato...	4	Reset
	Uncontrol flow	01.01.23   13:00 PM	M.line 1	3. Channel 5	2. Tomato...	4	Reset
	Uncontrol flow	01.01.23   13:00 PM	M.line 1	6. Channel 4	2. Tomato...	4	Reset

### 3. Select a date

### 4. View information about the alerts on the selected date

- **Severity:**
  - Critical
  - Not critical
- **Description:** Cause of the alert.
- **Date & Time:** When the alert was triggered.
- **Source:** The source of the alert.
- **Device:** The specific device which triggered the alert.
- **Program:** The name and number of the irrigation program which was running when the alert was triggered.
- **Shift:** The shift number at the time the alert was triggered.

### Reset buttons

Tap the **Reset** button to reset a specific alert, or tap the **Reset All** button to reset all active alerts. Once reset, these alerts are displayed in the **History Alerts** tab (see [Viewing Alert History](#)).

## 6.4.2 Viewing Alert History

History alerts displays a log of all alerts occurred in the past. Perform the following steps to view information about history alerts:

**2. Tap the History Alerts tab**

**1. Tap the Alerts button**

**3. Select date**  
Filter the display alerts for a specific date, see [Selecting Date](#).

**4. View information about the alerts on the selected date**

- **Status:** Options include:
  - **Triggered:**
  - **Untriggered:**
- **Severity:**
  - **N:** Normal
  - **C:** Critical
- **Severity:** Whether the alert is critical or not.
- **Reset By:** Name of the logged in user who reset the alert.
- **Date & Time:** When the alert was triggered.
- **Description:** Cause of the alert.
- **Source:** The source of the alert.
- **Device:** The specific device which triggered the alert.
- **Program:** The name and number of the irrigation program which was running when the alert was triggered.
- **Shift:** The shift number at the time the alert was triggered.

Status	Severity	Reset by	Date & Time	Description	Source	Device	Program	Shift
Triggered	N		19.10.2023   04:15:02	24VAC Recover				0
Untriggered	C		19.10.2023   00:10:11	Minimum Flow	M.line 1	WMTR1.1	Apple	3
Untriggered	N		19.10.2023   00:10:11	Minimum Flow	M.line 1	WMTR1.1	Apple	3

## 6.4.3 Defining Alert Settings

List of all available alerts that are part of the selected sub-system is displayed.

### Online alerts

The online Alerts icon is displayed on dashboard screens as either Active or Not active. Its color varies according to the severity of the alert.

**SMS** – Active alerts can be sent via SMS to Three phone numbers (see System preferences).

Clicking on each parameter leads to a dedicated screen, with all the functions for alerts.

**Disable & Reset Alerts** – Disable all alerts to be inactive.

**Alarms auto reset delay** – Specific time in which all alerts will be reset.

**1. Tap the Alerts button**

**3. Select the Sub-system**

Alerts are grouped by their sub-system. Select the sub-system that the alert is part of.

**2. Tap the Alerts Settings tab**

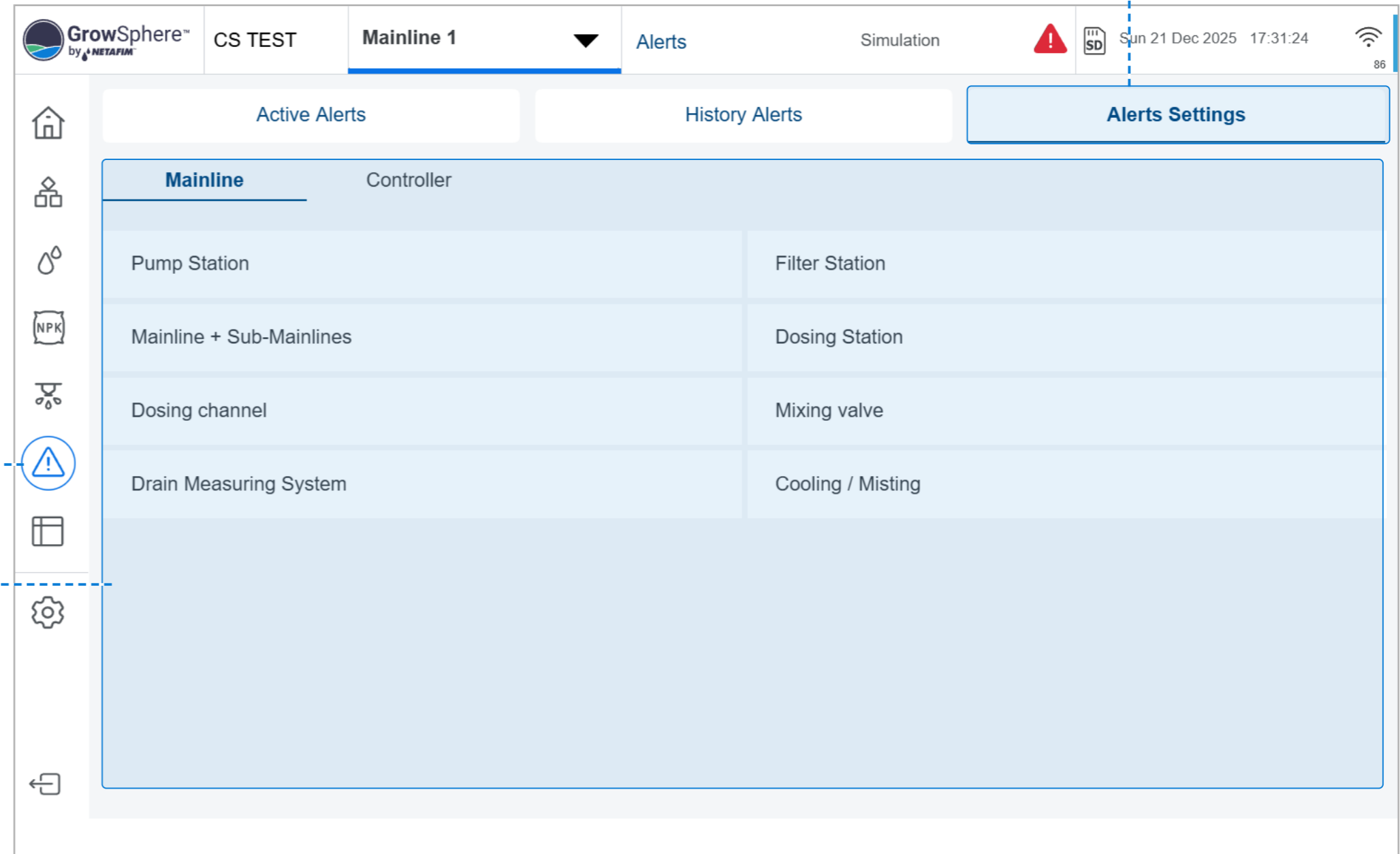

The alert settings screen is divided into two alert levels: normal and critical.

**Normal Alert Settings**

Description	Value	Delay (sec)	Action	sms
Maximum Flow	200.0 m	60s	Alert Only	<input type="checkbox"/>
Minimum Flow	0.1 m <sup>3</sup> /h	60s	Alert Only	<input type="checkbox"/>
High Flow	40.0 %	60s	Alert Only	<input type="checkbox"/>
Low Flow	30.0 %	60s	Alert Only	<input type="checkbox"/>
No Flow		60s	Pause Mainline	<input type="checkbox"/>
Uncontrol Flow	1000.0 L	60s	Alert Only	<input type="checkbox"/>
Maximum Pressure	6.0 Bar	60s	Alert Only	<input type="checkbox"/>

**Critical Alert Settings**

Description	Critical Value	Delay (sec)	Action	sms
Maximum Flow	250.0 m	120s	Alert Only	<input type="checkbox"/>
Minimum Flow	1.0 m <sup>3</sup> /h	120s	Alert Only	<input type="checkbox"/>
High Flow	45.0 %	120s	Alert Only	<input type="checkbox"/>
Low Flow	40.0 %	120s	Alert Only	<input type="checkbox"/>
No Flow		120s	Pause Mainline	<input type="checkbox"/>
Uncontrol Flow	1500.0 L	120s	Alert Only	<input type="checkbox"/>
Maximum Pressure	8.0 Bar	120s	Alert Only	<input type="checkbox"/>

**4. Define the following parameters:**

- **Description:** The system displays the description/name of the alert.
- **Value/Critical value:** The value that will trigger an alert.
- **Delay:** Defines the amount of time between when a fault is detected and the alert is triggered.
- **Action:** Action to take when an alert is triggered. Options include: Alert only, Pause Mainline, Stop dosing, Skip program.
- **SMS:** Option to receive an SMS notification when an alert is triggered.



## Alerts Settings

On this screen are the user settings for all the alerts.

- The user can select the mainline for the setting.
- Disable & Reset Alerts: when this box is selected all the active alerts will be reset and will be disable all the alerts.
- Alerts auto reset delay: when it is selected all the alerts will be reset automatically after the set time.
- The following sections are for the settings of each device. Each device settings in explained on the following screens.

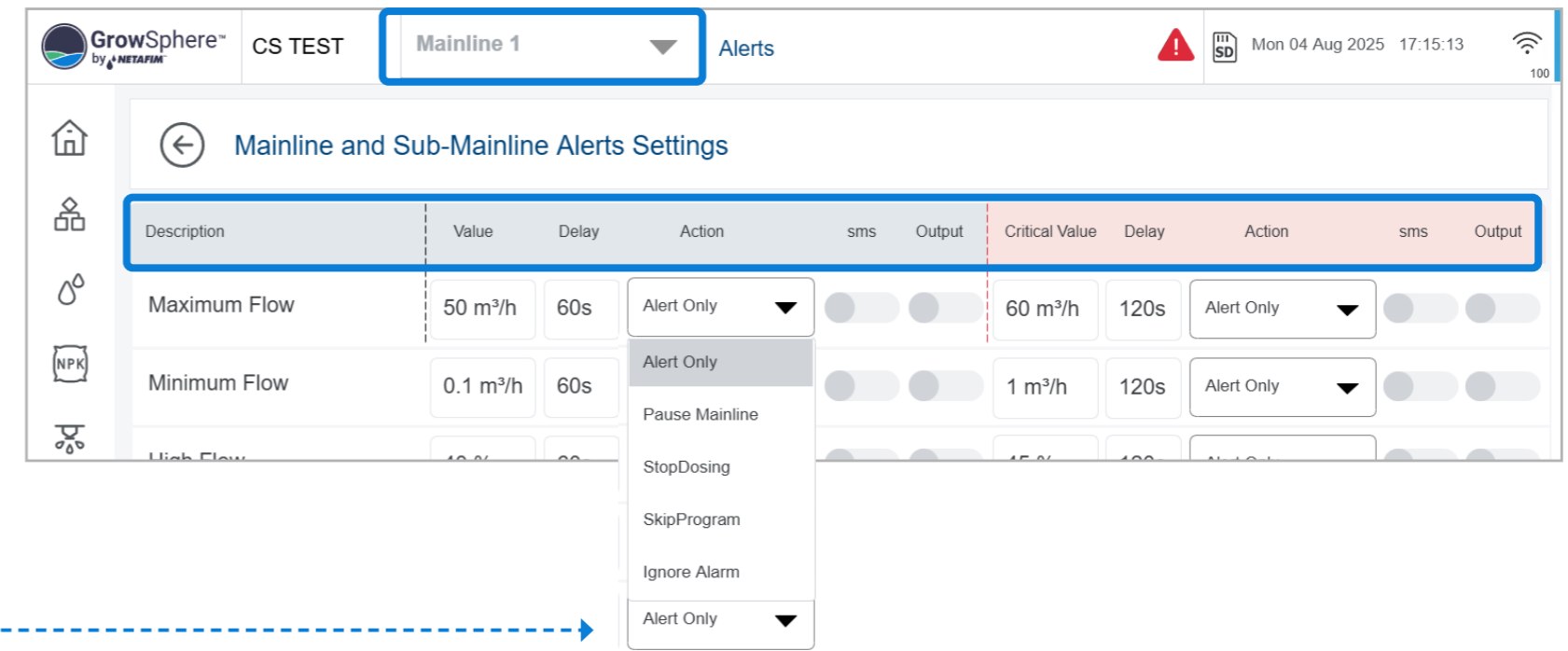

### Alerts Settings - Fields

The alerts fields for alerts settings are common for all the alerts devices.

The settings are for normal alerts and critical alerts. The fields are:

- **Description:** it is the alert description
- **Value:** it is a value to active the alert
- **Delay:** is the time that the alert need to active to turn to active alert.
- **Action:** the user can select the action that will be performance when the alarm is active.
- **sms:** when turned on an SMS with the alert description will be sent to the user.
- **Output:** when on the system I/O was defined an output for alerts (normal or critical), and the selector was turned to ON, then when the alert is active the output will be powered ON.
- These settings are the same for normal or critical alerts.



**Mainline:**

## Alerts Settings – Pump Station

The Pump Station settings are per mainline.

- Pump station input switch: When input pressure switch at pump station is activated, it will trigger this alert after the set delay.  
It is an alert to protect the pump when there is no water/pressure in the pump inlet.
- Pump Overload: it is a pump protection.

Description	Value	Delay	Action	sms	Output	Critical Value	Delay	Action	sms	Output
Pump station input switch		60s	Alert Only	<input type="checkbox"/>	<input type="checkbox"/>		120s	Alert Only	<input type="checkbox"/>	<input type="checkbox"/>
Pump Overload		60s	Alert Only	<input type="checkbox"/>	<input type="checkbox"/>		120s	Alert Only	<input type="checkbox"/>	<input type="checkbox"/>



**Mainline:**

## Alerts Settings – Mainline and Sub-mainline

Alerts setting for mainline and sub-mainline together.

Page 1.

- Maximum Flow: when the mainline flow rate exceeded the set value, the alert is activated.
- Minimum Flow: when the mainline flow rate is under the set value, the alert is activated.
- High Flow: when running shift flow rate is over its nominal flow rate by the set %, the alert is activated.
- Low Flow: when running shift flow rate is under its nominal flow rate by the set %, the alert is activated.
- No Flow: when there is an active irrigation and the water meter is not recording flow, the alert is activated.
- Uncontrol Flow: when the water meter is recording flow, when there is no running program.
- Maximum Pressure: when the mainline pressure is over the set value the alert is activated.

Description	Value	Delay	Action	sms	Output	Critical Value	Delay	Action	sms	Output
Maximum Flow	50.0 m³/h	60s	Alert Only	<input type="checkbox"/>	<input type="checkbox"/>	60.0 m³/h	120s	Alert Only	<input type="checkbox"/>	<input type="checkbox"/>
Minimum Flow	0.1 m³/h	60s	Alert Only	<input type="checkbox"/>	<input type="checkbox"/>	1.0 m³/h	120s	Alert Only	<input type="checkbox"/>	<input type="checkbox"/>
High Flow	40.0 %	60s	Alert Only	<input type="checkbox"/>	<input type="checkbox"/>	45.0 %	120s	Alert Only	<input type="checkbox"/>	<input type="checkbox"/>
Low Flow	30.0 %	60s	Alert Only	<input type="checkbox"/>	<input type="checkbox"/>	40.0 %	120s	Alert Only	<input type="checkbox"/>	<input type="checkbox"/>
No Flow		60s	Pause Mainlin	<input type="checkbox"/>	<input type="checkbox"/>		120s	Pause Mainlin	<input type="checkbox"/>	<input type="checkbox"/>
Uncontrol Flow	1000.0 L	60s	Alert Only	<input type="checkbox"/>	<input type="checkbox"/>	1500.0 L	120s	Alert Only	<input type="checkbox"/>	<input type="checkbox"/>
Maximum Pressure	6.0 Bar	60s	Alert Only	<input type="checkbox"/>	<input type="checkbox"/>	8.0 Bar	120s	Alert Only	<input type="checkbox"/>	<input type="checkbox"/>

page 1 of page 2



**Mainline:**

## Alerts Settings – Mainline and Sub-mainline

Alerts setting for mainline and sub-mainline together.

Page 2.

- Minimum Pressure: when the mainline pressure is under the set value the alert is activated.
- External Alarm: when a digital input was selected for external alarm, then when this DI is active the alarm will be activated after the delay.

GrowSphere™ by NETAFIM Farm **Mainline 1** Alerts Simulation 26.9°C Sun 26 May 2024 14:05:10

### Mainline Alerts Settings

Description	Value	Delay	Action	sms	Output	Critical Value	Delay	Action	sms	Output
Maximum Pressure	6.0 Bar	60s	Alert Only	<input type="checkbox"/>	<input type="checkbox"/>	8.0 Bar	120s	Alert Only	<input type="checkbox"/>	<input type="checkbox"/>
Minimum Pressure	0.5 Bar	60s	Alert Only	<input type="checkbox"/>	<input type="checkbox"/>	1.0 Bar	120s	Alert Only	<input type="checkbox"/>	<input type="checkbox"/>
External Alarm		60s	Alert Only	<input type="checkbox"/>	<input type="checkbox"/>				<input type="checkbox"/>	<input type="checkbox"/>

page 2 of page 2



**Mainline:**

## Alerts Settings – Dosing Station

The dosing station settings are per mainline.

Page 1.

- **Booster Pump Overload:** it is a pump protection, when it is activated, the alert will be triggered after the set delay.
- **EC1/ EC2 Sensor Malfunction:** when sensor readings are out of the sensor minimal or maximal values, the alert is activated after the set delay.
- **pH1/ pH2 Sensor Malfunction:** when the sensor readings are out of the sensor minimal or maximal values the alert is activated after the set delay.
- **EC Sensor Delta:** when the system has 2 EC sensor, and the difference of the sensor reading is bigger or smaller than the set delta value, the alert is activated after the set delay.
- **pH Sensor Delta:** when the system has 2 pH sensor, and the difference of the sensor reading is bigger or smaller than the set delta value, the alert is activated after the set delay.

Description	Value	Delay	Action	sms	Output	Critical Value	Delay	Action	sms	Output
Booster Pump Overload		60s	Alert Only	<input type="checkbox"/>	<input type="checkbox"/>		120s	Alert Only	<input type="checkbox"/>	<input type="checkbox"/>
EC1 Sensor Malfunction		60s	Alert Only	<input type="checkbox"/>	<input type="checkbox"/>		120s	Alert Only	<input type="checkbox"/>	<input type="checkbox"/>
EC2 Sensor Malfunction		60s	Alert Only	<input type="checkbox"/>	<input type="checkbox"/>		120s	Alert Only	<input type="checkbox"/>	<input type="checkbox"/>
pH1 Sensor Malfunction		60s	Alert Only	<input type="checkbox"/>	<input type="checkbox"/>		120s	Alert Only	<input type="checkbox"/>	<input type="checkbox"/>
pH2 Sensor Malfunction		60s	Alert Only	<input type="checkbox"/>	<input type="checkbox"/>		120s	Alert Only	<input type="checkbox"/>	<input type="checkbox"/>
EC Sensors Delta	1.0	60s	Alert Only	<input type="checkbox"/>	<input type="checkbox"/>	1.5	120s	Alert Only	<input type="checkbox"/>	<input type="checkbox"/>
pH Sensors Delta	1.0	60s	Alert Only	<input type="checkbox"/>	<input type="checkbox"/>	1.5	120s	Alert Only	<input type="checkbox"/>	<input type="checkbox"/>

page 1 of page 2



**Mainline:**

## Alerts Settings – Dosing Station

The dosing station settings are per mainline.

Page 2.

- Low EC values: when the EC values are lower than the target on the running shift recipe target, by the set %.
- High EC values: when the EC values are higher than the target on the running shift recipe target, by the set %.
- Emergency EC: when the EC values are higher then the set value.
- Low pH values: when the pH values are lower than the target on the running shift recipe target, by the set %.
- High pH values: when the pH values are higher than the target on the running shift recipe target, by the set %.
- Emergency pH : when the pH values are lower than the set value.

GrowSphere™ by NETAFIM Farm **Mainline 1** Alerts Simulation 27.5°C Sun 26 May 2024 14:34:59

### Dosing Station Alerts Settings

Description	Value	Delay	Action	sms	Output	Critical Value	Delay	Action	sms	Output
pH Sensors Delta	1.0	60s	Alert Only	<input type="checkbox"/>	<input type="checkbox"/>	1.5	120s	Alert Only	<input type="checkbox"/>	<input type="checkbox"/>
Low EC values	40.0 %	60s	Alert Only	<input type="checkbox"/>	<input type="checkbox"/>	50.0 %	120s	Alert Only	<input type="checkbox"/>	<input type="checkbox"/>
High EC values	40.0 %	60s	Alert Only	<input type="checkbox"/>	<input type="checkbox"/>	45.0 %	120s	Alert Only	<input type="checkbox"/>	<input type="checkbox"/>
Emergency EC	4.0	60s	Alert Only	<input type="checkbox"/>	<input type="checkbox"/>	3.5	120s	Alert Only	<input type="checkbox"/>	<input type="checkbox"/>
Low pH values	40.0 %	60s	Alert Only	<input type="checkbox"/>	<input type="checkbox"/>	45.0 %	120s	Alert Only	<input type="checkbox"/>	<input type="checkbox"/>
High pH values	40.0 %	60s	Alert Only	<input type="checkbox"/>	<input type="checkbox"/>	45.0 %	120s	Alert Only	<input type="checkbox"/>	<input type="checkbox"/>
Emergency pH	4.0	60s	Alert Only	<input type="checkbox"/>	<input type="checkbox"/>	3.5	120s	Alert Only	<input type="checkbox"/>	<input type="checkbox"/>

page 2 of page 2



Mainline:

## Alerts Settings – Dosing Channel

The dosing channels settings are per mainline.

- **Dosing ch high flow:** when the dosing channel flow rate exceeds the nominal flow of the running recipe by the set %.
- **Dosing ch low flow:** when the dosing channel flow rate is under the nominal flow of the running recipe by the set %.
- **Dosing ch no flow:** when the dosing channel has a dosing meter, and it is not recording flow when the dosing channel is running.
- **Uncontrol flow:** when the dosing channel has a dosing meter, and it is recording flow when the dosing channel is not running.
- **Dosing Pump Overload:** when the dosing channel has a protection, and it will activate the alert.
- **Fert Tank QTY:** when the fertilizer tank has an analog level sensor, and the value is lower than the set % value.
- **Fer Tank Low Switch:** when the fertilizer tank has a low-level Digital Switch, and it is activated it will activate the alert

The screenshot shows the 'Dosing Channel Alerts Settings' interface for 'Mainline 1'. The top navigation bar includes 'Farm', 'Mainline 1', 'Alerts', 'Simulation 27.3°C', and the date 'Sun 26 May 2024 14:55:23'. The main content area is a table with the following data:

Description	Value	Delay	Action	sms	Output	Critical Value	Delay	Action	sms	Output
Dosing ch high flow	30.0 %	60s	Alert Only	<input type="checkbox"/>	<input type="checkbox"/>	40.0 %	120s	Alert Only	<input type="checkbox"/>	<input type="checkbox"/>
Dosing ch low flow	80.0 %	60s	Alert Only	<input type="checkbox"/>	<input type="checkbox"/>	88.0 %	120s	Alert Only	<input type="checkbox"/>	<input type="checkbox"/>
Dosing ch no flow		60s	Stop Dosing	<input type="checkbox"/>	<input type="checkbox"/>		120s	Stop Dosing	<input type="checkbox"/>	<input type="checkbox"/>
Uncontrol flow	30.0 L	60s	Alert Only	<input type="checkbox"/>	<input type="checkbox"/>	50.0 L	120s	Alert Only	<input type="checkbox"/>	<input type="checkbox"/>
Dosing Pmp Overload		50s	Alert Only	<input type="checkbox"/>	<input type="checkbox"/>		60s	Alert Only	<input type="checkbox"/>	<input type="checkbox"/>
Fert Tank Low QTY	20.0 %	60s	Alert Only	<input type="checkbox"/>	<input type="checkbox"/>	15.0 %	120s	Alert Only	<input type="checkbox"/>	<input type="checkbox"/>
Fert Tank Low Level switch		60s	Alert Only	<input type="checkbox"/>	<input type="checkbox"/>		120s	Alert Only	<input type="checkbox"/>	<input type="checkbox"/>



Mainline:

## Alerts Settings – Mixing valve

The Mixing valve settings are per mainline.

- **Tank A low level:** when the tank A has a digital low-level switch, and it turns to active, then the alert is activated.
- **Tank B low level:** when the tank B has a digital low-level switch, and it turns to active, then the alert is activated.
- **Tanks A level below threshold:** when the tank A has an analog level sensor, and the readings are under the set level by % then it will activate the alert.
- **Tanks B level below threshold:** when the tank B has an analog level sensor, and the readings are under the set level by % then it will activate the alert.
- **Low (pre) EC values:** when the pre-EC sensor readings are lower than the set value then it will activate the alert.
- **High (pre) EC values:** when the pre-EC sensor readings are higher than the set value then it will activate the alert.

Description	Value	Delay	Action	sms	Output	Critical Value	Delay	Action	sms	Output
Tank A low level		60s	Pause Mainlin	<input type="checkbox"/>	<input type="checkbox"/>		120s	Pause Mainlin	<input type="checkbox"/>	<input type="checkbox"/>
Tank B low level		60s	Skip Program	<input type="checkbox"/>	<input type="checkbox"/>		120s	Skip Program	<input type="checkbox"/>	<input type="checkbox"/>
Tank A level below threshold	20.0	60s	Pause Mainlin	<input type="checkbox"/>	<input type="checkbox"/>	15.0	120s	Pause Mainlin	<input type="checkbox"/>	<input type="checkbox"/>
Tank B level below threshold	20.0	60s	Skip Program	<input type="checkbox"/>	<input type="checkbox"/>	15.0	120s	Skip Program	<input type="checkbox"/>	<input type="checkbox"/>
Low EC values	0.5	60s	Alert Only	<input type="checkbox"/>	<input type="checkbox"/>	0.3	120s	Alert Only	<input type="checkbox"/>	<input type="checkbox"/>
High EC values	2.5	60s	Alert Only	<input type="checkbox"/>	<input type="checkbox"/>	2.8	120s	Alert Only	<input type="checkbox"/>	<input type="checkbox"/>



Mainline:

## Alerts Settings – Filter Station

The Filter station settings are per mainline.

- **PD over threshold:** when the pressure differential value is over the set value. the alert is activated.
- **PD Signal Reiteration:** when the flushing program runs consecutively more that the set value, then an alert will be activated.
- **Over Max Cycle:** when the flushing cycle runs more cycles than the set value during the set time (delay) then an alert will be activated.
- **Filter Unit Malfunction:** when the station has a verification switch, and it is active when there is no flushing cycle then an alert will be activated.
- **Filter Unit Fails to Flush:** when the station has a verification switch, and it is not activated when filter is flushing, then an alert will be activated.
- **Sensor Pressure IN Malfunction:** when the pressure In sensor is under or over the maximal settings values, then an alert will be activated.
- **Sensor Pressure Out Malfunction:** when the pressure out sensor is under or over the maximal settings values, then an alert will be activated.

Description	Value	Delay	Action	sms	Output	Critical Value	Delay	Action	sms	Output
PD over threshold	2.0	60s	Alert Only	<input type="checkbox"/>	<input type="checkbox"/>	2.5	120s	Alert Only	<input type="checkbox"/>	<input type="checkbox"/>
DP Signal Reiteration	3.0		Alert Only	<input type="checkbox"/>	<input type="checkbox"/>	3.0		Alert Only	<input type="checkbox"/>	<input type="checkbox"/>
Over Max Cycle	2.0	6000s	Alert Only	<input type="checkbox"/>	<input type="checkbox"/>	2.5	7000s	Alert Only	<input type="checkbox"/>	<input type="checkbox"/>
Filters Unit Malfunction		60s	Alert Only	<input type="checkbox"/>	<input type="checkbox"/>		120s	Alert Only	<input type="checkbox"/>	<input type="checkbox"/>
Filter Unit Fails to Flush		60s	Alert Only	<input type="checkbox"/>	<input type="checkbox"/>		120s	Alert Only	<input type="checkbox"/>	<input type="checkbox"/>
Sensor Pressure IN Malfunction		60s	Alert Only	<input type="checkbox"/>	<input type="checkbox"/>		120s	Alert Only	<input type="checkbox"/>	<input type="checkbox"/>
Sensor Pressure Out Malfunction		60s	Alert Only	<input type="checkbox"/>	<input type="checkbox"/>		120s	Alert Only	<input type="checkbox"/>	<input type="checkbox"/>



Controller:

## Alerts Settings – System

The System alerts settings are for all mainlines.

- **PLC power recovery:** Notified that the controller power is reconnected after the set delay.
- **24VAC Fault:** Notified that the 24 VAC (voltage) is disconnected after the set delay.
- **24VAC Recovery:** Notified that the 24 VAC power is reconnected after the set delay.

Description	Value	Delay	Action	sms	Output	Critical Value	Delay	Action	sms	Output
PLC power recovery		60s	Alert Only	<input type="checkbox"/>	<input type="checkbox"/>		120s	Alert Only	<input type="checkbox"/>	<input type="checkbox"/>
24VAC Fault		60s	Alert Only	<input type="checkbox"/>	<input type="checkbox"/>		120s	Alert Only	<input type="checkbox"/>	<input type="checkbox"/>
24VAC Recover		60s	Alert Only	<input type="checkbox"/>	<input type="checkbox"/>				<input type="checkbox"/>	<input type="checkbox"/>



Controller:

## Alerts Settings – Remote System

The System alerts settings are for all mainlines.

- **Remote Valve Fault:** Notified when one of the irrigation valves from a RTU is faulty.
- **Modbus disconnected:** notified after the set delay, that there is no communication between the **GrowSphere™** controller and a sub station, weather Station, NetRTU GW or RTU host.

The screenshot shows the 'Remote System Alerts Settings' page in the GrowSphere MAX interface. The top bar indicates the current location is 'Farm' and 'Mainline 3'. The page title is 'Remote System Alerts Settings'. Below the title is a table with the following data:

Description	Delay (sec)	Action	sms
Remote Valve Fault	60 s	Alert Only	<input type="checkbox"/>
Modbus disconnected	60 s	Alert Only	<input type="checkbox"/>
SN: Unit disconnected	60 s	Alert Only	<input type="checkbox"/>



Controller:

## Reservoir and Wells alarms

- **Emergency – Reservoir low Level**, action: Alert Only, Pause main Lines (Pump Station Pumps).

Default – Pause main line

- **Emergency – Reservoir high Level**, actions: Alert Only, Stop Wells.

Default - Stop Wells.

- **Reservoir Low Level**, actions: Alert only, stop wells.

Default- Alert only.

- **Reservoir high Level**, actions: Alert only, stop wells.

Default- Alert only.

- **Well No Flow**, action: Alert Only, Stop Well.

Default- Stop well.

- **High Pressure Out**, action: Alert Only, Stop Well.

Default - Stop well.

- **Well pump protection**, action: Alert Only, Stop Well.

Default - Stop well pump

- **Well low-level switch**, action: Alert only, stop well.

Default- stop well pump

- **Well low-level sensor**, action: alert only, stop well.

Default- stop well

Description	Value	Delay	Action	sms	Output	Critical Value				
						Delay	Action	sms	Output	
Reservoir Emerg Low Level		60s	Alert Only	<input type="checkbox"/>	<input type="checkbox"/>	120s	Alert Only	<input type="checkbox"/>	<input type="checkbox"/>	
Reservoir Emerg High Level		60s	Alert Only	<input type="checkbox"/>	<input type="checkbox"/>	120s	Alert Only	<input type="checkbox"/>	<input type="checkbox"/>	
Reservoir Low Level		60s	Alert Only	<input type="checkbox"/>	<input type="checkbox"/>	120s	Alert Only	<input type="checkbox"/>	<input type="checkbox"/>	
Reservoir High Level		60s	Alert Only	<input type="checkbox"/>	<input type="checkbox"/>	120s	Alert Only	<input type="checkbox"/>	<input type="checkbox"/>	
Well O.L./PRS/Level switch		60s	Stop Well	<input type="checkbox"/>	<input type="checkbox"/>	120s	Stop Well	<input type="checkbox"/>	<input type="checkbox"/>	



Controller:

## Reservoir Alert Settings

GrowSphere™ by NETAFIM CS TEST Mainline 2 Alerts Simulation Sun 27 Jul 2025 17:34:25

Active Alerts History Alerts Alerts Settings

Disable All Alerts  Alarms auto reset delay (hh:mm) 00:01

- Pump Station
- Mainline + Sub-Mainlines
- Dosing Station
- Dosing channel
- Mixing valve
- Filter Station
- System
- Remote System
- Reservoir & wells

GrowSphere™ by NETAFIM Controller name All Mainlines 19°F Wed 13 Apr 2023 12:30 AM

Active Alerts History Alerts Alert Settings

Description	Value	Delay (Sec)	Action	sms	output	Critical value	Delay (Sec)	Action	sms	output
Emergency low level		00:60	Stop irrigation	<input type="checkbox"/>	<input type="checkbox"/>		02:00	Alert only	<input type="checkbox"/>	<input type="checkbox"/>
Emergency high level		00:60	None	<input type="checkbox"/>	<input type="checkbox"/>		02:00	Alert only	<input type="checkbox"/>	<input type="checkbox"/>
High flow	40.0%	00:60	Stop irrigation	<input type="checkbox"/>	<input type="checkbox"/>	02:00	02:00	Alert only	<input type="checkbox"/>	<input type="checkbox"/>
Low flow	30.0%	00:60	Pause Mainline	<input type="checkbox"/>	<input type="checkbox"/>	02:00	02:00	Alert only	<input type="checkbox"/>	<input type="checkbox"/>
No flow		00:60	Alert only	<input type="checkbox"/>	<input type="checkbox"/>				<input type="checkbox"/>	<input type="checkbox"/>
High pressure out	6.0 Bar	00:60	Stop irrigation	<input type="checkbox"/>	<input type="checkbox"/>	02:00	02:00	Alert only	<input type="checkbox"/>	<input type="checkbox"/>
Well O.L/Prs/Level Switch		00:60	Stop irrigation	<input type="checkbox"/>	<input type="checkbox"/>				<input type="checkbox"/>	<input type="checkbox"/>



Controller:

## Central Pump Station Settings

CS TEST

All Mainlines
▼

Alerts
Simulation
!
SD
Sun 21 Dec 2025 17:36:47
75

←
Central Pump Station

Description	Value	Delay	Action	sms	Output	Critical Value	Delay	Action	sms	Output
Station Low Pressure	10	600s	Alert Only ▼	<input type="checkbox"/>	<input type="checkbox"/>	20	1200s	Alert Only ▼	<input type="checkbox"/>	<input type="checkbox"/>
Station High Pressure	10	600s	Alert Only ▼	<input type="checkbox"/>	<input type="checkbox"/>	20	1200s	Alert Only ▼	<input type="checkbox"/>	<input type="checkbox"/>
Pump Input Pressure		600s	Alert Only ▼	<input type="checkbox"/>	<input type="checkbox"/>		1200s	Alert Only ▼	<input type="checkbox"/>	<input type="checkbox"/>
Pump Overload		600s	Alert Only ▼	<input type="checkbox"/>	<input type="checkbox"/>		1200s	Alert Only ▼	<input type="checkbox"/>	<input type="checkbox"/>



## 7. Controller Operation

This chapter reviews the following routine operations:

**1/** Managing Irrigation Programs

**4/** System Testing

**2/** Influences

**5/** Monitoring Irrigation

**3/** Viewing Logs



## 7.1 Managing Irrigation Programs

This section reviews managing irrigation programs and includes:

**1/** Irrigation Program Dashboard

**3/** Assigning Irrigation Program Shifts

**2/** Editing Irrigation Program Parameters

**4/** Selecting Dosing



## 7.1.1 Irrigation Program Dashboard

To create a new irrigation program, click on 'Insert new program'.

To edit an existing program – Click on the three dots of any program

**Irrigation Method** – Explained in chapter: General Program Settings.

**Amount of water to be used per shift, and total number of shifts per program**

**Date and time of next irrigation session**

### Irrigation Program Name

2. Tap the **checkbox** to enable (checked) or disable (unchecked) an irrigation program.

1. Tap the **Irrigation Programs** button to access the irrigation programs.

3. Tap the first empty line to define a new program

The Edit Program screen opens (see [Editing Irrigation Program Parameters](#)).

Program Name	Method	Amount of water to be used per shift, and total number of shifts per program	Date and time of next irrigation session
1 Almond	Routine	00:20:00   2 Shifts	17.09.23   08:00
2 Apple	Routine	02:50:00   2 Shifts	17.09.23   07:00
+ Insert new program			
+ Insert new program			
+ Insert new program			
+ Insert new program			
+ Insert new program			
+ Insert new program			
+ Insert new program			
+ Insert new program			
+ Insert new program			

### Alerts

See [Managing Alerts](#) for more information.

### Program Status

Shows one of the following program statuses:

- Waiting in queue
- In queue
- Paused by alarm
- Manually paused

(Optional) Tap the **Menu** button and select **Edit** to change the irrigation program parameters (see [Editing Irrigation Program Parameters](#)).



## 7.1.2 Editing Irrigation Program Parameters

The Program screen opens when creating a new program or editing an existing one.

This screen enables defining irrigation program parameters and includes:

The screenshot displays the 'Program 03' configuration screen. At the top, it shows the 'Farm' context, 'Mainline 1', and 'Irrigation' mode. A status bar indicates 'Program not activate!' with an 'Activate' button. The 'General Program Settings' section includes dropdowns for 'Type' (Routine), 'Priority' (Normal), and 'Unit' (HH:MM), along with input fields for 'Amount (shift)' (00:00), 'Factor' (100%), and 'Total' (00:00 | 0.00 m³). A 'Start times' table is present with columns for 'Start time', 'Trigger', 'Target', 'Max', and 'Min'. The 'Program Schedule Settings' section shows a 'Schedule' of 'Every (X) days' set to '1 day'. The 'Water before & after' section has 'Apply To' set to 'Per shift', 'Unit' as 'HH:MM', and 'Before'/'After' times of '00:00'.

Irrigation Program Top Bar

General Program Settings

Date and Time Settings

Program Schedule Settings

Water before and after



## Irrigation Program Top Bar

The irrigation program top bar changes depending on the state of the program as follows:

### Program is not running

Program can be activated following the initial settings by clicking Activate.

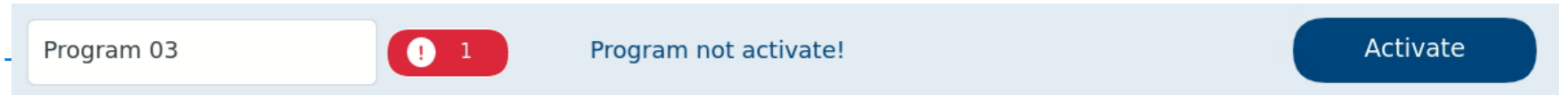

### Irrigation program is running

Options include Skip Options (Skip shift, Stop & Skip current irrigation, Skip next irrigation start time), or pausing the mainline.



### Irrigation program is not running

Options include skipping the program (it will be placed in the queue) or starting the program.

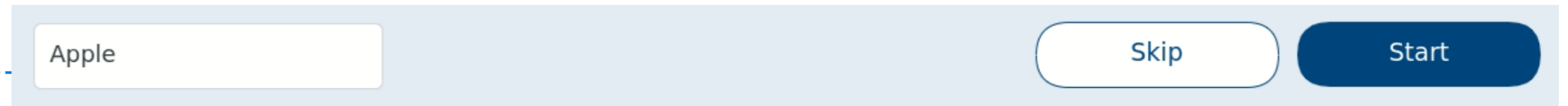

### Irrigation program is waiting in queue

The program become activated according to their order in the queue

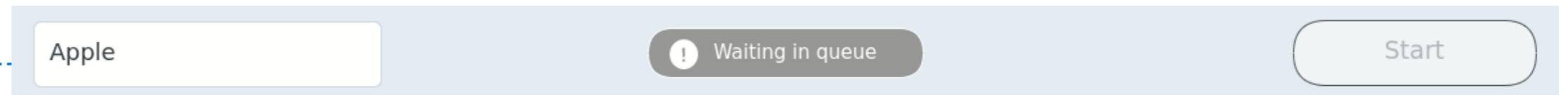

### Irrigation program was manually paused

Options include Skip Options (skipping on the current or next program) and resume the program.

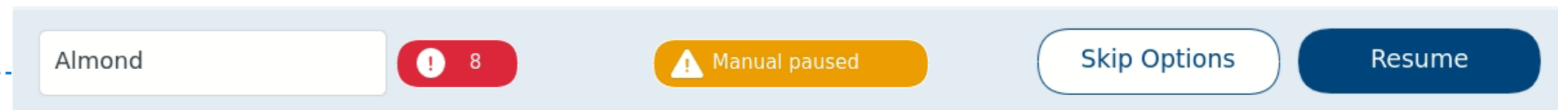

The Controller will generate alerts for the following conflicts when generating an irrigation program:

1. The program exceeds the Day End Time.
2. The total flow rate of an irrigation shift exceeds the maximal flow rate of the main line.
3. The total flow rate of an irrigation shift is below the minimal primary line flow rate.
4. An irrigation valve selected corresponds to a different main line.
5. The linked dosing recipe cannot be executed properly



## Manual Activation Start/Stop of Program

**An irrigation program may be started manually by a user. If this program has a future start time and date, then the user must choose whether the program will run immediately instead of at the initially programmed start time or in addition to it. The user can select to skip the next start time. When the Irrigation program has more than one start time, only the next start time waiting to be activated will be skipped.**

- The user selects whether the program runs now or at the set time and date. If the program runs now, it will wait until the current program is completed. If the user decides to cancel the irrigation program that is running, then the manual program will be executed.
- If the user wants to pause, skip a program or shift, or stop the program that is running, it keeps running until one of the following options is selected and confirmed:

1. Continue running, no change, and return to the previous screen
2. Pause the entire program, then confirm
3. End the entire program, then confirm
4. End the current irrigation shift and skip to the next shift in the sequence, then confirm. This happens when one or more shifts are in the sequence after the current shift (irrigation Vales). If it is the last shift in the irrigation program, then the program ends.

### NOTE

A shift can contain a single irrigation valve or a group of valves. A Shift can contain up to 16 irrigation valves. All the vales in a shift run simultaneously.

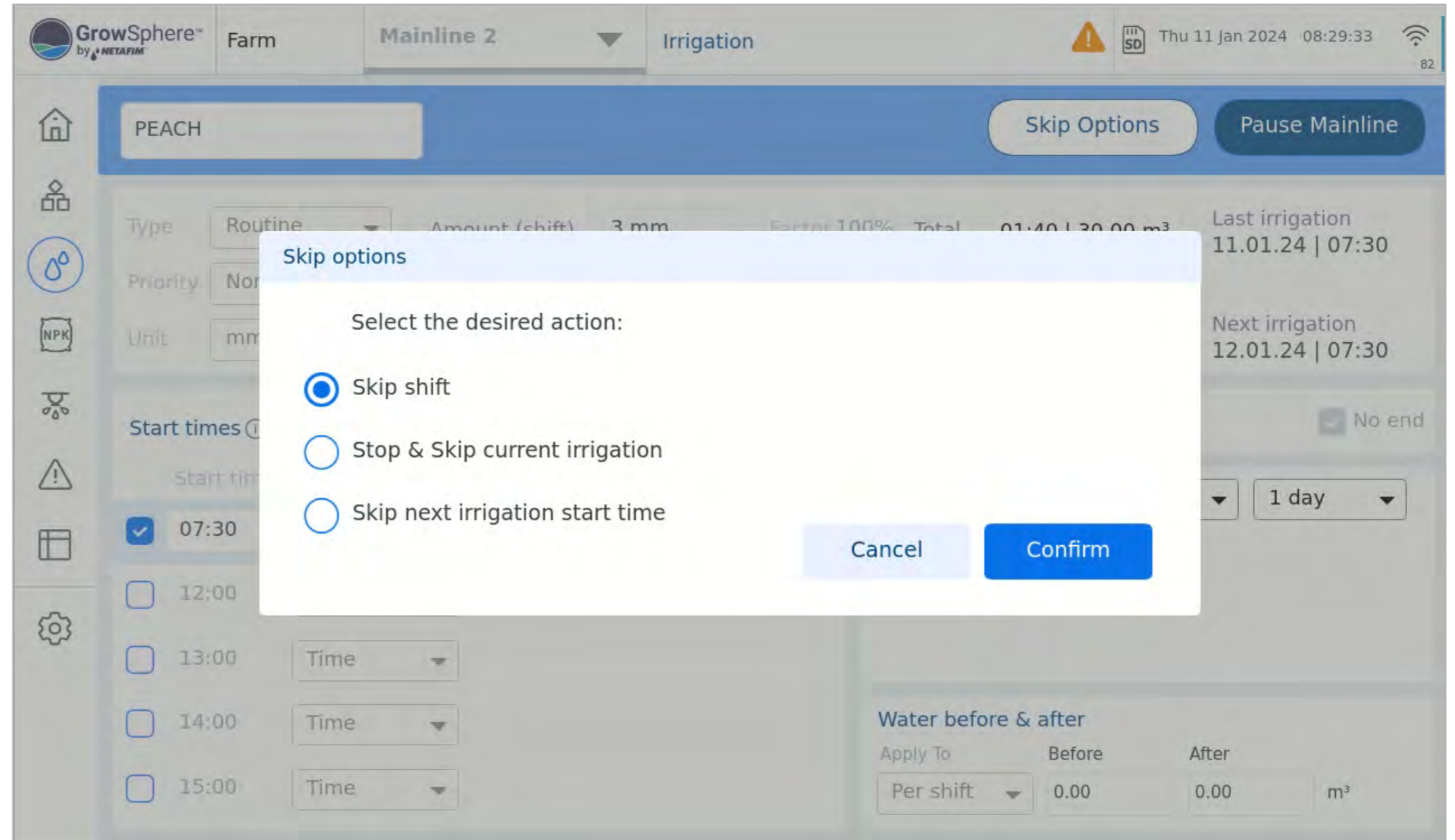

## General Program Settings

Perform the following steps to define the irrigation program's general settings:

### 1. Select the type

Options include One Time, Routine, Rolling and Emergency

**One-time Program** - The user can create a one-time program only for a one-time run. This program runs only on the specified day and time. Once execution is completed, it becomes inactive.

**Emergency Program** - The one with the highest priority, higher than any other programs designated with high priority. This program is executed immediately. Once completed, the Hydraulic Manager will resume the irrigation program that was paused.

**Rolling Program** - A regular program that has a Start Time, Start Date, and End Date, and it runs constantly in consecutive cycles. Once the last shift-irrigation ends, the sequence starts again.

**Routine program** - Operated routinely by date and time, and consists of Up to 5 start-times per day.

### 2. Select the priority

Enables designating the irrigation program's order in the queue. A **High** priority program is placed higher up in the queue and will thus execute before a **Normal** priority program.

### Amount

Displays amount of water used per irrigation shift (HH:MM).

### Total

Displays total amount of water to be irrigated and total irrigation time.

### Last/Next Irrigation

Displays the day/time when the last irrigation ended and when the next irrigation will start.

### 3. Select the unit

Enables defining the measurement unit. Options include: mm (millimeter), qty (quantity), and time (HH:MM or MM:SS).

### 4. Assign shifts

See [Assigning Irrigation Program Shifts](#)

### 5. Link a dosing recipe

See [Selecting Dosing](#)

### 6. Set start/end time, Triggers delays and radiation sensor (if directly wiring or weather station connected)

Fill up time for programs or shifts



## Date and Time Settings

Perform the following steps to define the irrigation program's time and parameters:

Start time	Trigger	Target	Max	Min
<input checked="" type="checkbox"/> 07:00	Time			
<input checked="" type="checkbox"/> 10:00	Rad Sum	0.0	00:00	00:00
<input type="checkbox"/> 15:00	none			
<input type="checkbox"/> 00:00	Time			
<input type="checkbox"/> 00:00	Cycle			
<input type="checkbox"/> 00:00	Rad Sum+			
<input type="checkbox"/> 00:00	Rad Sum			

### 3. Activate the irrigation start time(s)

A check mark indicates the irrigation start time is active. Up to five starting times can be activated in a 24-hour period.

### 4. Condition

To use Conditions – Please see the chapter: **Irrigation Programs – Conditions & Triggers**

Start time	Trigger
<input checked="" type="checkbox"/> 11:00	Conditions

### 2. Additional Settings

- **Target** – Target of radiation intensity to activate the irrigation cycle
- **Max** – Maximum radiation intensity beyond it irrigation will not be provided
- **Min** – Minimum radiation intensity under it irrigation will not be provided

### 1. Trigger

- **None** – Will use as an end to the previous start time without irrigation
- **Time** – By time
- **Cycle** – Every X time (set as a target)
- **Rad Sum +** - Start with irrigation and continue according to Rad sum thresholds
- **Rad Sum** – According to Radiation sum thresholds

This option is available only when Radiation sensors is configured in the system



## Program Schedule Settings

Perform the following steps to define the irrigation program's schedule:

### 1. Select one of the two scheduling options:

#### Week days

Irrigation occurs on specified days of the week, and the irrigation cycle can be either 1 or 2 weeks long.

### 2. Select whether irrigation includes only water (blue) or water and dosing (green), or no irrigation at all (None).

Tap the relevant day, The following menu appears, enabling selection of irrigation type:

#### Every (X) days

Irrigation occurs once every set number of days.

### Click on the icon to skip between the next or previous week scheduling



## Water before and after

Water before and after:

When a dosing recipe is linked to a shift, users can set delay options for Water Before and Water After using hh:mm:ss, m3, or THG units.

### 2. Select Time or Quantity

### 3. Define amount of time or quantity of water

### 1. Select Shift or Program

Defines whether water before and after delivery of fertilizer occurs before and after the irrigation program or for the shifts in the irrigation program.

### Water before & after

Apply To: Per shift ▼

Before: 00:00

After: 00:00 mm:ss

#### Before

Dosing recipe starts to operate after the specified period or water quantity has been reached.

#### After

Irrigation continues without dosing for the set period of time or water quantity.

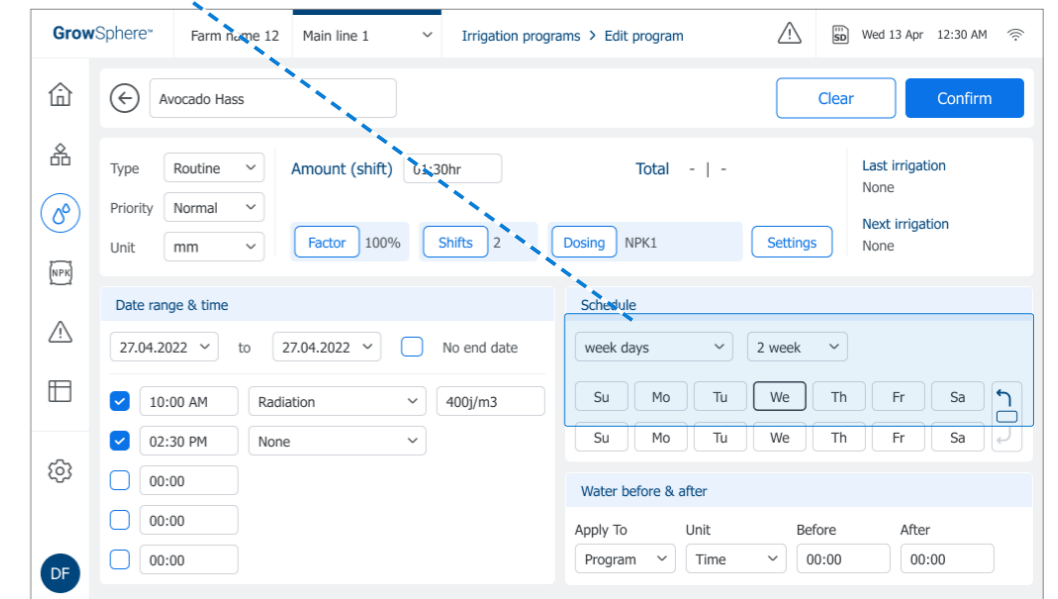

## 7.1.3 Assigning Irrigation Program Shifts

### Shifts Overview Screen

Perform the following steps to review, activate, add, edit, or delete shifts which are part of the irrigation program:

**1. Tap the Irrigation programs button in the irrigation program's general settings section (see [General Program Settings](#))**

A screen opens which enables managing shifts.

**2. Select the relevant shift(s)**

Select the check box of the shifts to be assigned to the irrigation program.

To change the order of the shifts, tap the **Reorder shifts** button (see [Reordering Shifts](#)).

**3. Tap the Add new shift button to create a new shift (see [Editing Shift Parameters](#)).**

Active	Shift name	Time ()	Factor(%)	Dosing	Valves	Flow (m³/h)	Duration left ()
<input type="checkbox"/>	Shift 01	03:59	100	For project book	2	50.0	23:39:14
<input checked="" type="checkbox"/>	Shift 02	03:59	100	For project book	2	50.0	03:59:00
<input checked="" type="checkbox"/>	Shift 03	03:59	100	For project book	2	50.0	03:59:00

**4. Review current shift information:**

- **Active:** Check mark indicates shift is active.
- **Shift status:** Colored bar indicates an active status of a shift.
- **Shift name:** The name of the shift.
- **Amount:** Water to be supplied per shift. Can be in mm, quantity, HH:MM or MM:SS (according to predefined units).
- **Factor:** Percentage to be added or reduced from the irrigation shift (100% is the predefined shift time or quantity).
- **Dosing:** Dosing recipe linked to the irrigation shift (see [Selecting Dosing](#)).
- **Valves:** Number of valves assigned to each shift.
- **Duration left (m3):** Amount of water until completion of a shift. .



## Editing Shift Parameters

This screen opens when editing a shift or creating a new one.

Perform the following steps to edit the shift parameters:

Shift can include valves from different sub mainlines

### 1. Name the shift

Shift 01

### 2. Enter the amount of water used in the shift and the water budget factor

Time(hh:mm) 00:00

Factor(%) 100

### 3. Link a dosing recipe

Dosing No recipe

### NOTE

If a dosing recipe is selected for the entire irrigation program (see [Selecting Dosing](#)), it will override the dosing recipe selected here.

### 4. Select checkboxes of valves to be added to the shift

001 V1

20.0 m<sup>3</sup>/h

002 V2

20.0 m<sup>3</sup>/h

003 V3

20.0 m<sup>3</sup>/h

Valves assigned to a different shift are marked with a link icon.

### Total nominal flow rate

The nominal flow of the selected valves and the nominal flow of the main line. If the total flow rate of all selected valves exceeds the flow rate of the main line, the text becomes red.

### 5. Tap arrow buttons to view additional valves



page 1 of page 1



Done

### 6. Tap Done



## Reordering Shifts

The order of the shifts represents the sequence in which shifts are executed during an irrigation session. Perform the following steps to reorder shifts:

**1. Tap the Reorder shifts button in the Shifts Overview Screen**

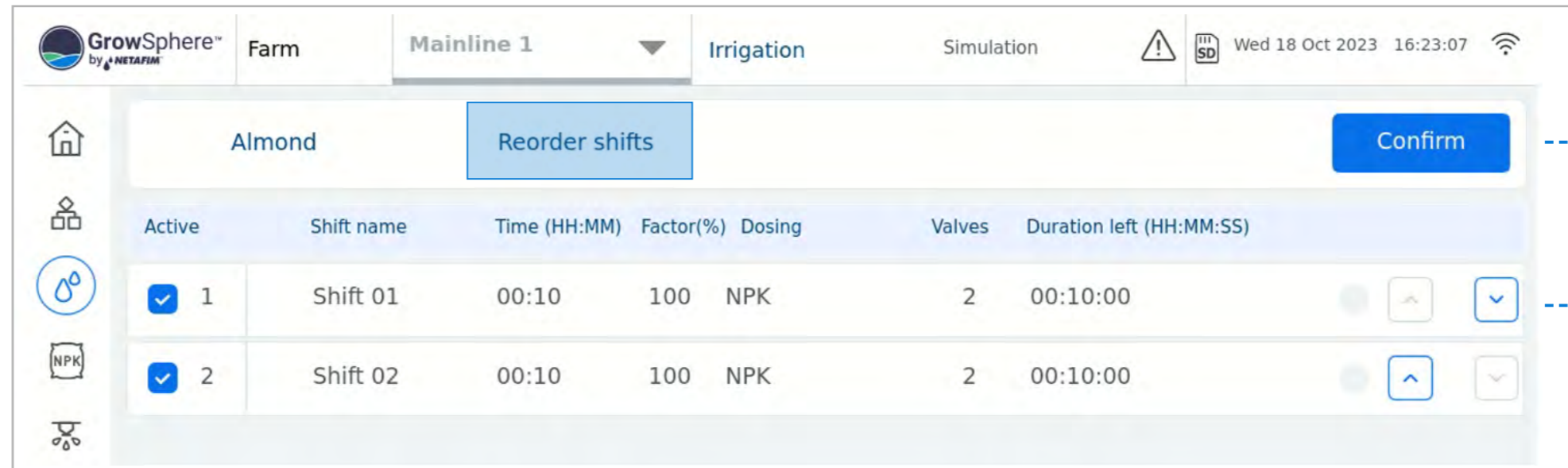
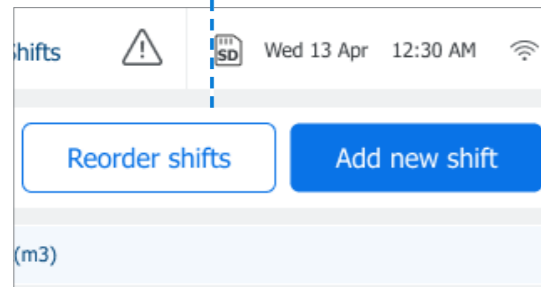

**3. Tap Confirm to save changes**

**2. Tap the arrows to move shifts up and down**

**NOTE**

Irrigation proceeds according to the order of shifts in the list, starting from the top.



## 7.1.4 Selecting Dosing

Perform the following steps to link a dosing recipe to the irrigation program:

### 1. Tap the Dosing button in the irrigation's general settings section

A screen opens which enables the selection of a dosing recipe.

#### NOTES

- The dosing recipe selected here overrides the dosing recipe selected when creating a shift.
- For more information about dosing recipes, see [Managing Fertilizer Dosing](#).

### 2. The Dosing screen opens

Enables the selection of a dosing recipe.

### 3. If no dosing is necessary, select No dosing

No dosing

### 4. Select a dosing recipe

### 5. Tap Save



## 7.2 Irrigation Program Settings & Influence

Checkbox option to bypass scheduled start and end times for the program.

**Line fill delay**  
Adjustable delay for line filling before irrigation starts.

**Triggers Section**  
On delay: Time before irrigation starts after trigger (format: mm:ss).

Off delay: Time before irrigation stops after trigger.

Delay between cycles: Interval between irrigation cycles (format: hh:mm).

Toggle between Per program and Per shift.

**Radiation Sensor Section**

Options:

Weather station sensor (selected in screenshot).

Local sensor (dropdown to select specific sensor).

This is relevant for Radiation Sum irrigation programs.



## Influence Settings

This section allows you to adjust irrigation and fertigation behavior based on environmental or sensor data. It introduces dynamic control by applying factors that modify EC, irrigation time, or other parameters according to real-time conditions.

### Last Read

Shows the most recent sensor reading.

### Sensor

Displays which sensor is linked (e.g., drain sensor, radiation sensor).

### Influence

Lists the type of relationship between sensor data and system behavior.

### Status

Indicates if the influence is active or inactive.

### Factor

Displays the adjustment factor applied to EC or irrigation time.

### Edit Button

Opens configuration for each influence rule (example in next page)

**GrowSphere™ by NETAFIM** Controller name **Mainline 1** 19°F Wed 13 Apr 2023 12:30 AM

**Settings** (General | **Influence**)

Influence	Sensor / system	Last read	Status	Factor	Edit
Drain / Radsum	DMS 1.1	35 %	Low	+15%	Edit
Drain / Min time	DMS 1.1	35 %	Optimal	0	Edit
Drain EC / EC	EC1.1	35 dS/m	High	-10%	Edit
Radiation / EC	RAD1	35 w/m²	Optimal	0	Edit
Temp / EC	TEMP1	35 °F	Optimal	0	Edit
VPD / EC	TEMP 1 , RH 1	35 KPa	Optimal	0	Edit
Drain / Irrigation					Edit

**RADSUM** Original | Factored: 250 | 285

**EC** Original | Factored: -- | --

**MIN TIME** Original | Factored: 00:05:00 | 00:05:00

**IRRIGATION** Original | Factored: 05:00 | 05:42



- For each influence, users define the measured input value and the corresponding influence percentage
- Influences are recalculated after each irrigation cycle and reset at midnight.

Supported Influence Types:

- Drainage % on RadSum target
- Drainage % on RadSum minimum time
- EC drain on EC target
- Radiation on EC target
- Temperature on EC target
- VPD on EC target
- Drainage % on irrigation amount/time



## 7.3 Viewing Logs

This section reviews system event logs and includes:

**1/** Irrigation Logs

**2/** Uncompleted Irrigation Log

**3/** Accumulation events

**4/** Meters Accumulation Events Logs

**5/** Filter Logs

**6/** Events Logs

**7/** Pump Logs

**8/** Alarm Logs

**9/** Weather station logs

**10/** Reservoir/Pump logs

**11/** Central Pump logs

**12/** Energy Meter logs

Logs are generated for different events, presented on a dedicated Logs screen, and saved on the SD card. The main logs are:

- Irrigation events and uncompleted irrigation events
- Accumulation of water and dosing amounts for all irrigation valves
- Meters accumulation, such as water meter or fertilizer meter, etc.
- Filter flushing events
- Irrigation events include when a valve closes, a pump stops, dosing starts, etc.
- Using multiple filter options, such as Between, Equals, Greater / less than, and Reorder and sorting columns is optional.



## Accessing Logs

Perform the following steps to view a log:

### 2. Select a log from the list

Select the relevant type of log report you wish to view.

The screenshot shows the GrowSphere MAX interface. At the top, there is a navigation bar with the following items: GrowSphere™ by NETAFIM, CS TEST, Mainline 2 (with a dropdown arrow), Reports, Simulation, a warning icon, an SD card icon, the date and time 'Mon 22 Dec 2025 14:11:50', and a signal strength icon. Below the navigation bar is a sidebar with icons for Home, Mainline, Irrigation, Accumulation, Filter, Events, Drain Accumulation, Settings, and Back. The 'Mainline' icon is circled in blue, and a dashed line points from the text '1. Tap the Reports button' to it. The 'Mainline' menu item is highlighted in light blue. A dashed line also points from the text '2. Select a log from the list' to the 'Mainline' menu item. The main content area shows a table with two columns: 'Mainline' and 'Controller'. The table contains the following rows:

Mainline	Controller
Irrigation	Uncompleted Irrigation
Accumulation	Meters Accumulation
Filter	Pumps
Events	Drain
Drain Accumulation	

1. Tap the Reports button



**2. Select a log from the list**

Select the relevant type of log report you wish to view.

The screenshot shows the GrowSphere MAX user interface. At the top, there is a navigation bar with the following items: GrowSphere™ by NETAFIM, CS TEST, All Mainlines (with a dropdown arrow), Reports, Simulation, a warning icon, an SD card icon, the date and time 'Mon 22 Dec 2025 14:12:44', and a signal strength icon. Below the navigation bar, there is a sidebar with icons for Home, Reservoir & wells, Central pump station, NPK, Weather Station, Alerts History, Energy meters accumulation, and Settings. The main content area is divided into two tabs: 'Mainline' and 'Controller'. The 'Controller' tab is selected and highlighted in blue. Below the 'Controller' tab, there is a list of log types: Reservoir & wells, Central pump station, Central pump Daily accumulation, Weather Station, Alerts History, and Energy meters accumulation. A dashed blue line points from the '2. Select a log from the list' text to the 'All Mainlines' dropdown menu.



Mainline:

## 7.3.1 Irrigation Logs

Perform the following steps to view a log of irrigation shifts which completed successfully:

### 3. Select date

See [Selecting Date](#).

### 2. Select Irrigation Logs from the list of logs (see [Accessing Logs](#))

### 1. Tap the Reports button

#### NOTE

A new record is added to the irrigation log when an irrigation shift ends.

General												
Program	Compl	Valve	Sub-Line	Date	Start	Trigger	Shift	Duration, hh:mm	Qty, m³	mm	m³/h	Recipe
Test IT	Y	V4	2	07.27.2025	11:50:41	Cycle	2	00:13:59	4.6	0.02	19.73	npk2.1
Test IT	Y	V3	1	07.27.2025	11:50:41	Cycle	2	00:13:59	4.6	0.02	19.73	npk2.1
Test IT	N	V4	2	07.27.2025	11:00:03	Cycle	2	00:46:01	15.35	0.08	20.01	npk2.1
Test IT	N	V3	1	07.27.2025	11:00:03	Cycle	2	00:46:01	15.35	0.08	20.01	npk2.1
Test IT	Y	V2	1	07.27.2025	10:00:02	Cycle	1	01:00:00	20	0.1	20	npk2.1
Test IT	Y	V1	1	07.27.2025	10:00:02	Cycle	1	01:00:00	20	0.1	20	npk2.1
Test IT	Y	V4	2	07.27.2025	09:00:02	Cycle	2	01:00:00	20	0.1	20	npk2.1
Test IT	Y	V3	1	07.27.2025	09:00:02	Cycle	2	01:00:00	20	0.1	20	npk2.1
Test IT	Y	V2	1	07.27.2025	08:00:01	Cycle	1	01:00:00	20	0.1	20	npk2.1

### 4. Review irrigation log details:

- **Irrigation status icon:** Indicates a valve's irrigation status. Options include:
  - Set irrigation amount was attained
  - Set irrigation amount was not attained
- **Program:** Irrigation program to which the shift belongs.
- **Completed:** Irrigation was completed (Yes) or not (No).
- **Valve:** Irrigation valve name.
- **Sub Mainline** - Sub mainline number
- **Date:** The date when the irrigation shift occurred.
- **Start:** Start time of the irrigation shift.
- **Trigger:** The trigger which started the irrigation shift.
- **Shift:** Shift number.
- **Duration:** Total irrigation shift time.
- **Qty/m3:** Water quantity delivered by the valve.
- **mm:** Water quantity set for the irrigation program or shift. This quantity is the same for all valves in the shift.
- **m3/h:** Average flow rate during irrigation shift as measured by the main line water meter. If the main line doesn't have a water meter, this value will be the sum of the flow rate of all valves in the shift.



## Irrigation Logs

### 4. Review irrigation log details (cont.):

- **Recipe:** The dosing recipe linked to the irrigation shift.
- **pH Avg:** The average pH measured during the shift.
- **EC Avg:** The average EC measured during the shift.

### Dosing Channels:

The amount of fertilizer injected during the shift relevant for each dosing channel:

- **Planned:** The planned amount calculated according to the recipe.
- **Actual:** The actual metered amount.

Irrigation Logs							1. DCH1.1		2. DCH1.2		3. DCH1.3	
Program	Compl	Valve	Recipe	pH Avg	EC Avg	Planned	Actual	Planned	Actual	Planned	Actual	
ORCHARD	N	POM	538 1L	7.8	1.4						0.03	
ORCHARD	N	PEACH	538 1L	7.8	1.4						0.03	
ORCHARD	N	CITRUS	538 1L	7.8	1.4						0.03	
HERB	Y	HERB	538 1L	7.8	1.4						0.18	
HERB	N	HERB	538 1L	7.6	0.0						0.11	



## Dosing Logs

Perform the following steps to view a log of dosing events:

**2. Select Irrigation Logs** from the list of logs (see [Accessing Logs](#))

**1. Tap the Reports button**

**3. Select date**

See [Selecting Date](#).

**4. Review dosing log details:**

Program	Compl	Valve	Date	Start	Trigger	Shift	Duration, hh:mm	Qty, m <sup>3</sup>	mm	m <sup>3</sup> /h	Recipe	pH Avg
ORCHARD	N	POM	01.01.2024	21:34:10	Time	1	00:21:59	0.008	0.001	0.02	538 1L	7.8
ORCHARD	N	PEACH	01.01.2024	21:34:10	Time	1	00:21:59	0.008	0.001	0.02	538 1L	7.8
ORCHARD	N	CITRUS	01.01.2024	21:34:10	Time	1	00:21:59	0.008	0.001	0.02	538 1L	7.8
HERB	Y	HERB	01.01.2024	20:52:17	Time	1	00:41:52	0.073	0.007	0.1	538 1L	7.8
HERB	N	HERB	01.01.2024	09:43:01	Time	1	00:03:00	0.002	0	0.04	538 1L	7.6

- **Irrigation status icon:** Indicates a valve's irrigation status. Options include:
  - ✓ Set irrigation amount was attained.
  - ✗ Set irrigation amount was not attained.
- **Valve:** Irrigation valve number.
- **Completed:** The irrigation was completed (Yes) or not (No).
- **Recipe:** The dosing recipe linked to the shift.
- **Date:** The date when the irrigation shift occurred.
- **Start:** Start time of the irrigation shift.
- **Duration:** Total irrigation shift time.
- **Qty/m<sup>3</sup>:** Water quantity delivered by the valve.
- **mm:** Water quantity set for the irrigation program or shift. This quantity is the same for all valves in the shift.
- **m<sup>3</sup>/h:** Average flow rate during irrigation shift as measured by the main line water meter. If the main line doesn't have a water meter, this value will be the sum of the flow rate of all valves in the shift.



Mainline:

## 7.3.2 Uncompleted Irrigation Logs

Perform the following steps to view a log of irrigation events which were not completed:

**3. Select date**

See [Selecting Date](#).

**2. Select Uncompleted Irrigation Logs** from the list of logs (see [Accessing Logs](#))

**1. Tap the Reports** button

General							Duration, hh:mm		Qty, m <sup>3</sup>		
Valve	Reason	Program	Date	Start	Trigger	Recipe	Left	Planned	Left	Planned	Left
POM	Midnight	ORCHARD			Time	538 1L	02:00:00	02:00:00	0.4	0.4	0.04
PEACH	Midnight	ORCHARD			Time	538 1L	02:00:00	02:00:00	0.4	0.4	0.04
CITRUS	Midnight	ORCHARD			Time	538 1L	02:00:00	02:00:00	0.4	0.4	0.04

**4. Review uncompleted irrigation log details:**

- **Valve:** Valve number.
- **Reason:** The reason why the irrigation shift was not completed.
- **Program:** Irrigation program to which the shift belongs.
- **Date:** The date when the irrigation shift occurred.
- **Start:** Irrigation event start time.
- **Recipe:** The dosing recipe linked to the irrigation shift.



## Uncompleted Irrigation Logs

General			mm		m <sup>3</sup> /h	1. DCH1.1		2. DCH1.2		3. DCH1.3	
Valve	Reason	Program	Left	Planned	AVG	Left	Planned	Left	Planned	Left	Planned
POM	Midnight	ORCHARD	0.04	0.04	0						
PEACH	Midnight	ORCHARD	0.04	0.04	0						
CITRUS	Midnight	ORCHARD	0.04	0.04	0						

### 4. Review uncompleted irrigation log details (cont.):

Each of the following parameters includes two values: amount left and amount planned.

- **Duration:** Irrigation shift time.
- **Qty/m<sup>3</sup>:** Water quantity delivered by the valve.
- **mm:** Water quantity set for the irrigation program or shift. This quantity is the same for all valves in the shift.
- **m<sup>3</sup>/h:** Average flow rate during irrigation shift as measured by the main line water meter. If the main line doesn't have a water meter, this value will be the sum of the flow rate of all valves in the shift.

#### Dosing Channels:

The amount of fertilizer injected during the shift relevant for each dosing channel:

- **Planned:** The planned amount calculated according to the recipe.
- **Actual:** The actual metered amount.



Mainline:

### 7.3.3 Accumulation events

Perform the following steps to view a log of the filter flushing:

General					Channels				
1 Valve	2 Start date	3 Duration, hh:mm	4 mm	5 Qty, m <sup>3</sup>	1 (L)	2 (L)	3 (L)	4 (L)	5
VLV3.4	26.10.2024	03:56:59	7.9	79.04	0	0	0	0	0
VLV3.3	26.10.2024	03:56:59	7.9	79.04	0	0	0	0	0
VLV3.2	26.10.2024	03:56:59	7.9	79.03	0	0	0	0	0
VLV3.1	26.10.2024	03:56:59	7.9	79.03	0	0	0	0	0

- 1. Valve ID
- 2. Start date of the event
- 3. Duration of the event
- 4. QTY in mm
- 5. QTY in m<sup>3</sup>
- 6. Channels - Dosing channels



Mainline:

## 7.3.4 Meters Accumulation Events Logs

Perform the following steps to view the amount of water that was flowing through the water meter:

**2. Select Meters Accumulation Events from the list of logs (see [Accessing Logs](#))**

**1. Tap the Reports button**

**3. Select date**

See [Selecting Date](#).

**4. Review meter accumulation log details:**

- **Meter:** Name of the meter.
- **Start Date:** The date when the irrigation shift occurred.
- **Qty/m3:** The amount of water (M3) irrigated.

Meter	Start date	Qty, WM-m³ DM-L
DMTR1.4	18.03.2024	0
DMTR1.3	18.03.2024	0
DMTR1.2	18.03.2024	0
DMTR1.1	18.03.2024	0
WMTR1.1	18.03.2024	31.377

**NOTE**

The system accumulates the amounts of water/fertilizers on a daily basis and resets its counters at midnight.



Mainline:

## 7.3.5 Filter Logs

Perform the following steps to view a log of the filter flushing:

**2. Select Filter Logs**  
from the list of logs  
(see [Accessing Logs](#))

**1. Tap the Reports button**

**3. Select date**

See [Selecting Date](#).

**5. Station Name**

**6. Daily Count**

**4. Review filter log details**

- **Date:** Date irrigation occurred.
- **Start time:** Time irrigation started.
- **Flushing trigger:** The time when the filter flushing was triggered.

Date	Start time	Flushing trigger	Station name	Daily Count
22.12.2025	14:20:21	Time	FS1	15
22.12.2025	13:19:59	Time	FS1	14
22.12.2025	12:19:38	Time	FS1	13
22.12.2025	11:19:16	Time	FS1	12
22.12.2025	10:18:54	Time	FS1	11
22.12.2025	09:18:33	Time	FS1	10
22.12.2025	08:18:11	Time	FS1	9
22.12.2025	07:17:50	Time	FS1	8
22.12.2025	06:17:28	Time	FS1	7
22.12.2025	05:17:07	Time	FS1	6



Mainline:

## 7.3.6 Events logs

GrowSphere™ by NETAFIM™		Farm	Mainline 1	Reports	! SD	Tue 15 Oct 2024 09:56:01	76
← Irrigation events		15.10.2024		Refresh	page 1 of page 3		
Date 1	Time 2	Description 3	Device 4	Source 5			
15.10.2024	09:05:02	Pump Start	P2				
15.10.2024	09:02:02	Pump Stop	P3				
15.10.2024	09:01:02	Pump Stop	P1				
15.10.2024	09:00:09	Closed	Almond2	Main line 1			
15.10.2024	09:00:08	Dosing Start	Dosing station	Main line 1			
15.10.2024	09:00:08	Opened	Almond4	Main line 1			
15.10.2024	09:00:03	Closed	almond1	Main line 1			

1. Date of the irrigation event

2. Time – of the irrigation event

3. Description – of the event during the irrigation

4. Device – Device in operation

5. Source – Mainline ID of the specific event



Mainline:

## 7.3.7 Pump logs

Date <b>1</b>	Start time <b>2</b>	Pump <b>3</b>	Duration <b>4</b>	Qty mm <b>5</b>	Qty m3 <b>6</b>
14.10.2024	23:58:59	3	01:53:51	0	0
14.10.2024	23:58:59	2	03:50:22	0	0
14.10.2024	23:58:59	1	02:01:52	0	0

**1. Date of the pump event**

**2. Start time – of the pump event**

**3. Pump – ID of the pump**

**4. Duration – of pump event**

**5. QTY mm – Delivered in mm during the event**

**6. QTY Q<sup>3</sup> – Delivered in Q3 during the event**



Controller:

## 7.3.8 Alarm Logs

This log displays alarm log reports, as selected by date.

### 3. Select date

See [Selecting Date](#).

2. Select Alarms Report from the list of logs (see [Accessing Logs](#))

1. Tap the Reports button

Status	Severity	Reset by	Date & Time	Description	Source	Device	Program	Shift
Reset	N		18.03.2024   14:30:42	No Flow	M.line 1	WMTR1.1	Program 02	1
Untriggered	N		18.03.2024   14:29:38	Low Flow	M.line 1	WMTR1.1	Program 02	1
Untriggered	N		18.03.2024   14:29:38	Minimum Flow	M.line 1	WMTR1.1	Program 02	1
Triggered	N		18.03.2024   14:29:37	No Flow	M.line 1	WMTR1.1	Program 02	1
Triggered	N		18.03.2024   14:29:37	Low Flow	M.line 1	WMTR1.1	Program 02	1
Triggered	N		18.03.2024   14:29:37	Minimum Flow	M.line 1	WMTR1.1	Program 02	1
Reset	N		18.03.2024   14:27:08	No Flow	M.line 1	WMTR1.1	Program 02	1

### 4. Review alarm log details:

- **Status:** Alerts status
- **Number:** Alarm number.
- **Severity:** Alert severity. Options include:
  - Critical
  - Not critical
- **Reset By:** Name of the logged in user who reset the alert.
- **Date & Time:** The date & time when the irrigation shift occurred.
- **Description:** Description of the alert.
- **Source:** the mainline.
- **Device:** The specific device which triggered the alert.
- **Program:** The name and number of the irrigation program which was running when the alert was triggered.
- **Shift:** shift number inside the program.



Controller:

## 7.3.9 Weather station logs

GrowSphere™ by NETAFIM | MAX CS Demo | Mainline 2 | Reports | Tue 05 Aug 2025 14:35:11

Weather Station Daily Logs | 03.08.2025 | Refresh | page 1 of page 11

Date	Time	Temperature (°C)			Humidity (%)			Solar radiation (w/m²)			
		Low	Actual	High	Low	Actual	High	High	Actual	Daily	Lo
03.08.2025	23:58:48	-	-	-	-	-	-	-	-	-	-
03.08.2025	23:43:48	-	-	-	-	-	-	-	-	-	-
03.08.2025	23:28:48	-	-	-	-	-	-	-	-	-	-
03.08.2025	23:13:48	-	-	-	-	-	-	-	-	-	-
03.08.2025	22:58:48	-	-	-	-	-	-	-	-	-	-
03.08.2025	22:43:48	-	-	-	-	-	-	-	-	-	-
03.08.2025	22:28:48	-	-	-	-	-	-	-	-	-	-



Controller:

## 7.3.10 Reservoir/Pump logs

Well Num.	Trigger by	Start time & date	End time & date	Water QTY(m³)	Avg.flow rate (m³/h)	Well level (%)
1	level	11.01.2026 12:24:15	11.01.2026 16:00:10	0	0	0

**1. Well Number: 1-6**

**2. Trigger by: Time /Level sensor**

**3. Start Time & Date**

**4. End Time & Date**

**5. Water quantity according to the water meter**

**6. Avg. Flow rate**

**7. Well level: according to level sensor in %**



## I Reservoir Activity logs

GrowSphere™ by NETAFIM CS TEST Mainline 2 Reports Simulation Sun 27 Jul 2025 17:21:54 99

- Irrigation Logs
- Uncompleted Irrigation Logs
- Accumulation Events
- Meters Accumulation Events
- Alarm Events
- Filter logs
- Events logs
- Pumps logs
- Weather Station Logs
- Reservoir & wells Log

GrowSphere™ by NETAFIM CS TEST All Mainlines Reports Simulation Thu 08 Jan 2026 10:04:11 84

← Reservoir & wells Log 05.01.2026 Refresh page 1 of page 1

Well Num.	Trigger by	Start time & date	End time & date	Water QTY(m³)	Avg.flow rate (m³/h)	Well level (%)
2	Time	05.01.2026 11:48:09	05.01.2026 12:00:10	0	0	0



Controller:

## 7.3.11 Central Pump logs

GrowSphere™ by NETAFIM Controller name **Mainline 1** 19°F ⚠️ 📄 Wed 13 Apr 2023 12:30 AM 📶

Central pump events log page 2 of page 8 21.03.23

Name	Start date	Time	Start / Stop
Pump station	21.03.25	10:30	Start
Pump station	21.03.25	10:30	Stop
Pump station	21.03.25	10:30	Start
Pump station	21.03.25	10:30	Stop
Pump station	21.03.25	10:30	Start
Pump station	21.03.25	10:30	Stop
Pump station	21.03.25	10:30	Start
Pump station	21.03.25	10:30	Stop
Pump station	21.03.25	10:30	Start
Pump station	21.03.25	10:30	Stop

GrowSphere™ by NETAFIM Controller name **Mainline 1** 19°F ⚠️ 📄 Wed 13 Apr 2023 12:30 AM 📶

Central pump Daily accumulation page 2 of page 8 21.03.23

Name	QTY (m³/GAL)	Time
Pump 1	1000	10:30
Pump 2	500	11:00
Pump 3	1000	10:30
Pump 4	500	11:00
Pump 5	1000	10:30
Pump 6	500	11:00
Pump 7	1000	10:30
Pump 8	500	11:00
Pump 1	1000	10:30
Pump 2	500	11:00



Controller:

## 7.3.12 Energy Meter logs

GrowSphere™ by NETAFIM CS TEST Mainline 1 Reports Simulation Thu 11 Dec 2025 12:37:48 80

Energy Meters Accumulation 10.12.2025 Refresh page 1 of page 1

Meter	Start date	Qty
ENERGY0.1	10.12.2025	0 kW



## 7.4 System Testing

This section reviews testing of the system and includes:

**1** / **Simulating Flow Rates and Sensor Values**

**2** / **Testing Devices**



## 7.4.1 Simulating Flow Rates and Sensor Values

Perform the following steps to perform a simulation of valves/pumps operation, sensors indications, and flow rates:

When testing without hydraulic components (valves, water/dosing meters, EC/pH & Pressure sensors) in order to properly run the system without alarm, you would require to set-up simulation mode:

This tab is separated to 3 main parts:

### 1. Water + Dosing meters

In this section you can configure your main water meter as well as dosing meters parameters:

- **Liter/Pulse:** automatically pulled from settings
- **Flow:** the required flow
  - M.WM Manual/Auto Flow
  - Unchecked – manually input main flow
  - Checked – automatically pulls the nominal flow for each shift according to the shift's valves

**2. Off delay:** a time delay in which pulses will be generated after the valve is off (designed to simulate dosing meter inertia)

### 3. Auto/On/Off

- Auto – pulses will be generated when the respected valve/channel is open
- On – pulses will be generated all the time
- Off – no pulses will be generated

**4. EC + pH Sensors:** configure you EC/pH levels

**5. Pressure:** configure you pressure sensors levels (in Bar)

Finally, turn the simulator on by pressing the On Button, an indication for working in simulation mode will appear in the top bar

### 3. Tap the Simulator tab

	Liter/Pulse	Flow	Off delay (sec)	Pulse/Min	Auto	On	Off
Main W.M	10.00	25 m³/h	0	41.7	<input checked="" type="radio"/>	<input type="radio"/>	<input type="radio"/>
DM_1	1.00	500 L/h	0	8.3	<input checked="" type="radio"/>	<input type="radio"/>	<input type="radio"/>
DM_2	1.00	500 L/h	0	8.3	<input checked="" type="radio"/>	<input type="radio"/>	<input type="radio"/>
DM_3	1.00	500 L/h	0	8.3	<input checked="" type="radio"/>	<input type="radio"/>	<input type="radio"/>
DM_4	1.00	150 L/h	0	2.5	<input checked="" type="radio"/>	<input type="radio"/>	<input type="radio"/>
DM_5	0.00	1 L/h	0	0.0	<input type="radio"/>	<input type="radio"/>	<input checked="" type="radio"/>
DM_6	0.00	1 L/h	0	0.0	<input type="radio"/>	<input type="radio"/>	<input checked="" type="radio"/>
	0.00	1 L/h	0	0.0	<input type="radio"/>	<input type="radio"/>	<input checked="" type="radio"/>
	0.00	1 L/h	0	0.0	<input type="radio"/>	<input type="radio"/>	<input checked="" type="radio"/>

1. Tap the Configuration button

2. Select Admin and type your credentials

4. Tap On

5. Adjust the parameters



## 7.4.2 Testing Devices

This screen is useful to manually operate or test the devices connected to the output modules and read the indications received from sensors and other devices connected to the inputs modules. Verify the following to manually test the system devices:

**1. Tap the Configuration button**

**2. Select Admin and type your credentials**

**3. Tap the Test tab**

**4. Tap the Test button**  
Tap the **Test** button of the relevant output to activate it. When the output is on, the Test button turns blue. Verify that the device is functioning correctly.

**5. Test IO from Expansion box**

The screenshot shows the following interface elements:

- Top bar: GrowSphere™ by NETAFIM, CS TEST, All Mainlines (dropdown), Admin, warning icon, SD icon, Tue 05 Aug 2025 15:34:13, Wi-Fi icon, 100% battery.
- Navigation tabs: Simulator, **Test**, System.
- PLC Selection: Main PLC (unselected), **ExBox 1 PLC** (selected).
- Output Modules:
 

Module	I/O	Device	Test
PM5052	DI 0		
	DI 1		
	DI 2		
	DI 3		
	DI 4		
	DI 5		
	DI 6		
	DI 7		
DO572 - 2	DO 0		Test
	DO 1		Test
	DO 2		Test
	DO 3		Test
	DO 4		Test
	DO 5		Test
	DO 6		Test
DO572 - 3	DO 0		Test
	DO 1		Test
	DO 2		Test
	DO 3		Test
	DO 4		Test
	DO 5		Test
	DO 6		Test
DO572 - 4	DO 0		Test
	DO 1		Test
	DO 2		Test
	DO 3		Test
	DO 4		Test
	DO 5		Test
	DO 6		Test



## 7.5 Monitoring Irrigation

This section reviews monitoring irrigation and includes:

**1/** Selecting the Mainline

**2/** Irrigation Dashboard

**3/** Monitoring Valves

**4/** Cooling and misting in SCADA

**5/** Analytics in SCADA

**6/** Queue in SCADA

**7/** Accumulation in SCADA

**8/** Sensors in SCADA



## 7.5.1 Selecting the Mainline

Perform the following to select the relevant mainline to open the SCADA screen:

### 1. Select the relevant mainline

Select the relevant mainline to open the SCADA screen.

**GrowSphere™** Farm name 12 Main Line 1 ⚠️ SD Wed 13 Apr 12:30 AM 📶

Mainline 1 <span>⏸️ Paused by Alert</span> <span>1 / 3 m<sup>3</sup></span>							
Irrigation	Flow	Pressure	Amount	Dosing	Shift	Next in Q	
Pomme (dame rose)	50 m3/h	1 Bar	3 mm	NPK1	3/24	--	
Mainline 2 <span>04:10 / 05:30 hr</span>							
Irrigation	Flow	Pressure	Amount	Dosing	Shift	Next in Q	
Apple (pink lady)	30 m3/h	1.5 Bar	05:30 hr	Pink lady	6/8	Orange	
Mainline 3 <span>7 / 15 m<sup>3</sup></span>							
Irrigation	Flow	Pressure	Amount	Dosing	Shift	Next in Q	
Avocado Hass Su	10 m3/h	2 Bar	15m <sup>3</sup>	Hass	4/10	--	
Mainline 4 <span>0000 / 0000 unit</span>							
Irrigation	Flow	Pressure	Amount	Dosing	Shift	Next in Q	
--	--	--	--	--	--	--	



## 7.5.2 Irrigation Dashboard

The irrigation dashboard includes the following:

Tap the General tab

Display the SCADA

To access the irrigation SCADA, verify the **SCADA** button is selected.

System devices

Indicates the devices statuses and enables setup/manual activation.

Current running program

Includes live information of the running program.

Top bar

When an irrigation program is running, buttons enable pausing the program, skipping the current shift, or stopping the program.



Dosing recipes

Displays the dosing recipe in use, the dosing unit devices, and information regarding the dosing channels.



## Manual Operation

Perform the following steps to enable manual operation of the pump, main valve, booster pump, and dosing channel:

### 1. Tap the relevant device

A dropdown menu is displayed.

### 2. Select the device state

Output device can be set to:

**Auto** - Device is activated according to the irrigation program.

**Manual On** - Device is activated.

**Manual Off** - Device is turned off.

### 3. Verify device state

The **M** icon indicates that the device is in Manual mode.

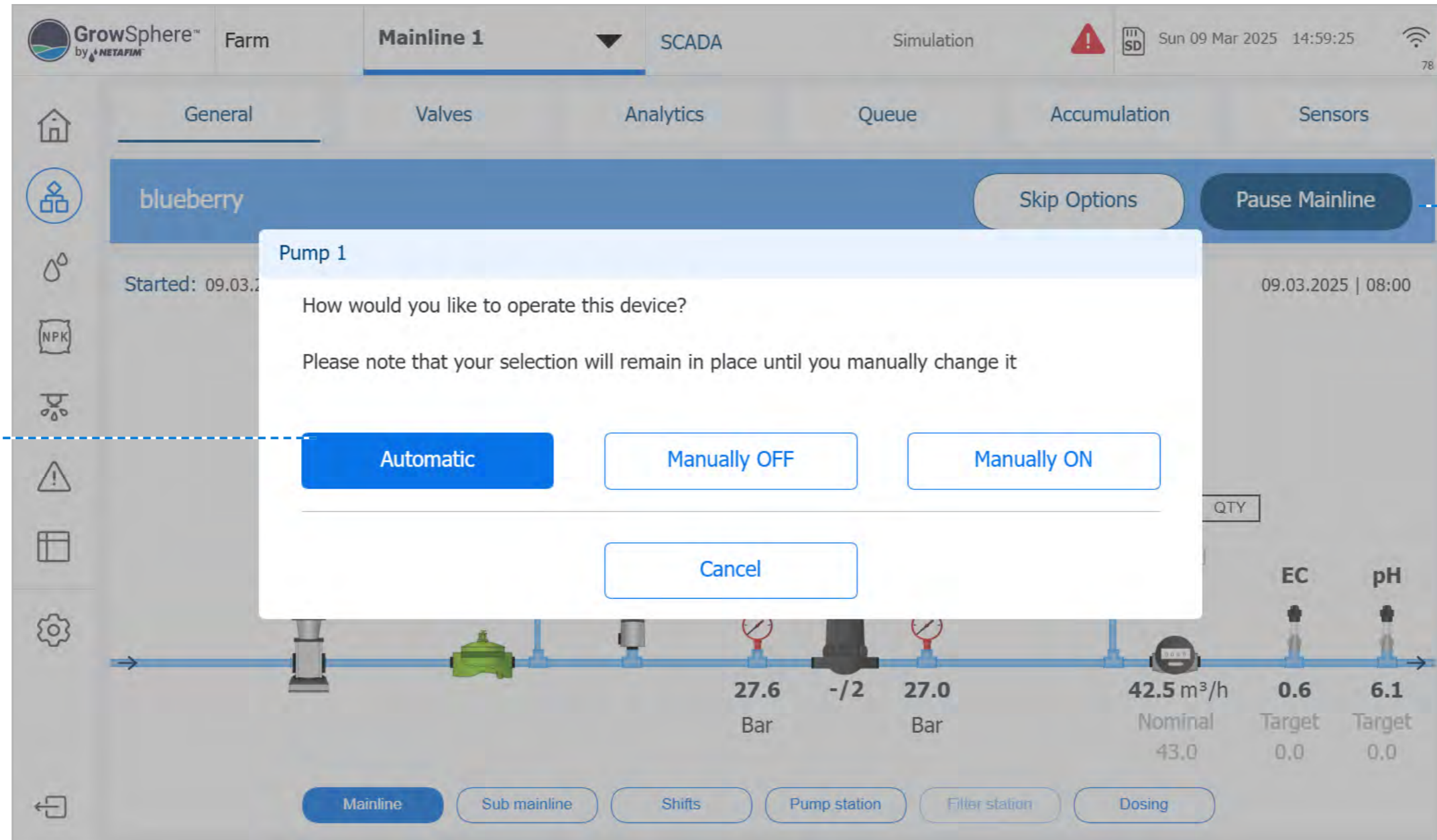

### Pause Mainline

Tap to pause the program.

### NOTE

The device remains in manual mode until it is set back to automatic.



## Irrigation Program Paused

A running irrigation program can be paused for one of the following two reasons:

### Program manually paused

When the irrigation program is manually paused by the user, the top bar and progress bar turn orange. Top bar buttons enable skipping to the next shift or resuming the program.

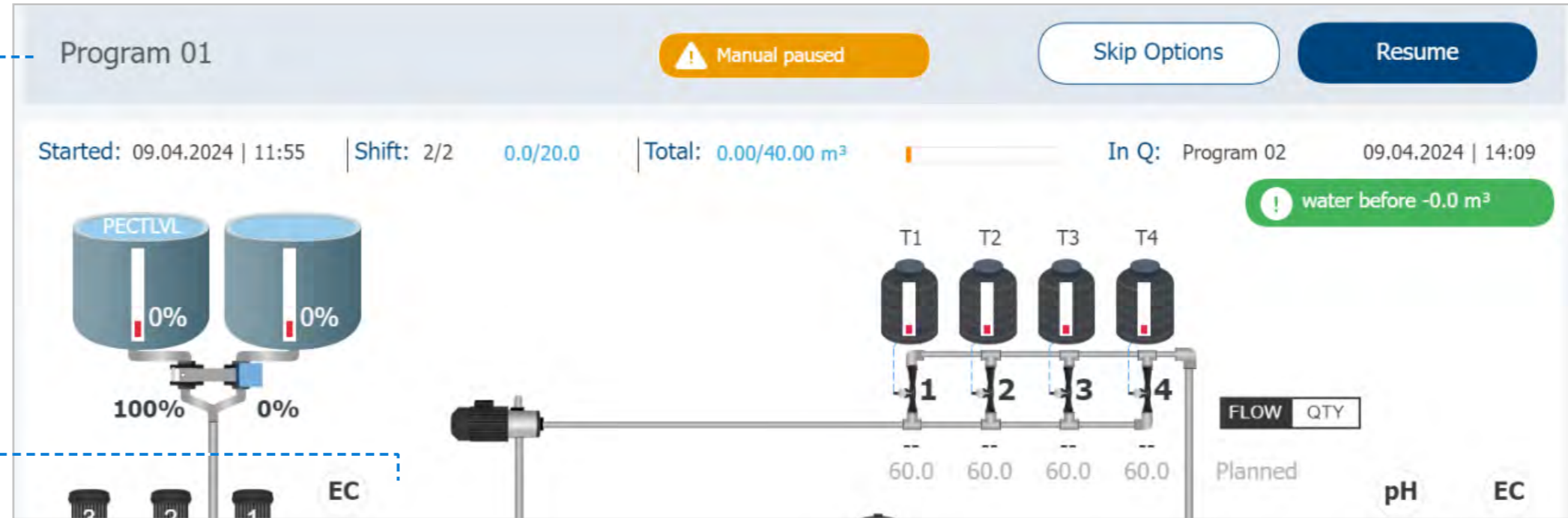

### Program paused by system

When the irrigation program is automatically paused by the system (due to a high severity alert), the top bar and progress bar turn red. The top bar buttons enable stopping the program or resuming the program.

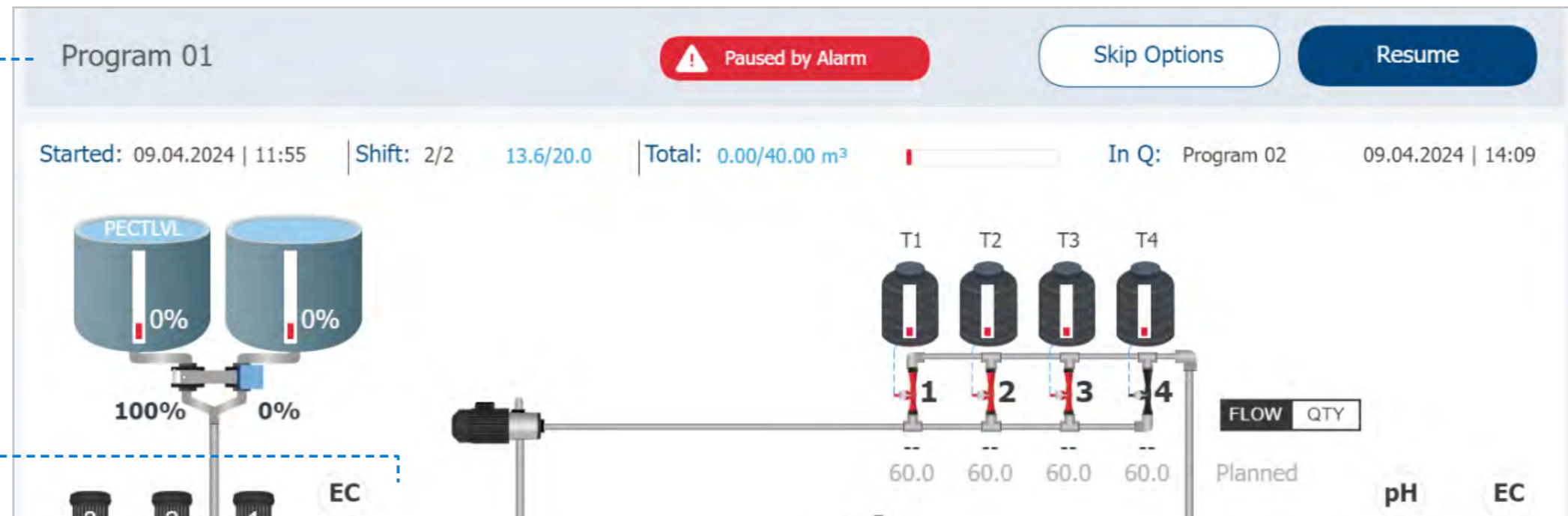

## 7.5.3 Monitoring Valves

The **Valves** tab displays all of the valves which are linked with the main line. This screen is useful to view the status of valves. Perform the following steps to view the valves:

**1. Tap the SCADA button** -----

**2. Tap the Valves tab** -----

**3. Select which valves are displayed** -----

Options include:

- **All:** Display all valves.
- **Alert:** Display only the valves which have triggered an alert.
- **Manual:** Display only the valves which are manually operated.
- **Not Assigned:** Display only the valves which are not assigned to a shift.

**Updating valve activation method**

To update how a valve is activated (i.e., automatically or manually), tap the valve and select the relevant option from the menu.

**Valve status indication:**

- Alert
- Irrigating
- Not Assigned
- Off/Not Active
- Manual On

**NOTE**

Each main valve can have up to 100 irrigation valves.



## 7.5.4 Cooling and misting in SCADA

Ability to monitor the cooling and misting valve activity

Manual activation is possible

Show number of running programs

User define overlapping between valve groups

The screenshot displays the GrowSphere MAX SCADA interface. At the top, the 'Mainline 2' controller is selected. The 'Valves' tab is active, and the 'Cooling & misting' filter is applied. The interface shows two sections: 'Cooling valves' and 'Misting valves'. In the 'Cooling valves' section, the 'COOL2.1' valve is shown with a green indicator and a manual activation button (M). In the 'Misting valves' section, the 'MIST2.1' valve is shown with a green indicator and a manual activation button (M), while 'MIST2.2' is shown with a grey indicator and a manual activation button (M).



## 7.5.5 Analytics in SCADA

1. Tap the SCADA button

3. Select the graph type

EC and pH measurements can be displayed in relation to the water flow.  
Pressure can be displayed in relation to the flow.

2. Tap the Analytics tab

4. Select the timeline scale

Change the X-axis to display the relevant timeline scale.

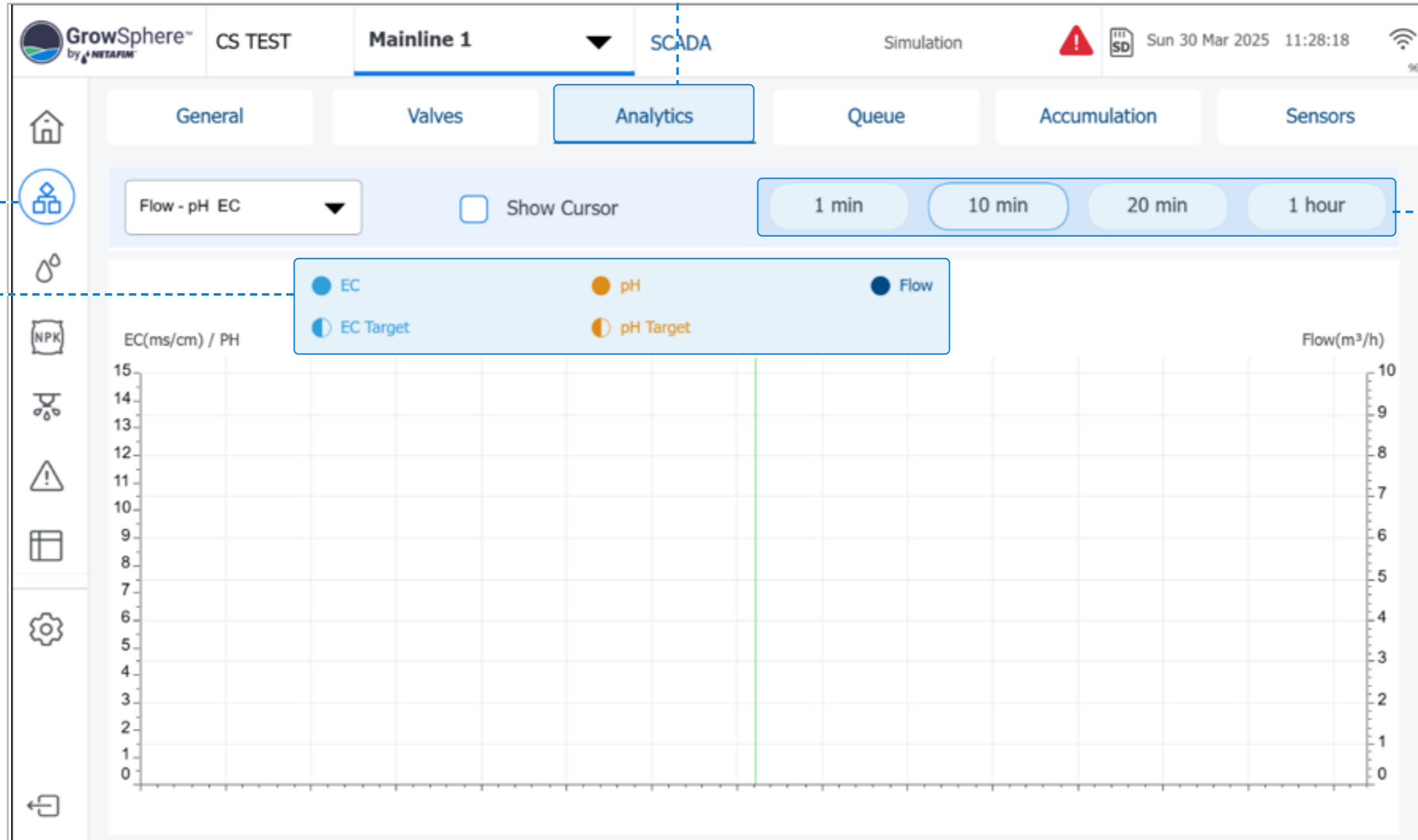

## 7.5.6 Queue in SCADA

The **Queue** tab displays the irrigation programs waiting to be executed, sorted by Normal priority and High priority. Perform the following steps to manage the queued programs:

**1. Tap the SCADA button**

**2. Tap the Queue tab**

**3. Select the relevant program**  
Tap the program name to select it.

**3. Tap Remove to remove the selected program from the list.**

**Maximum waiting time before Normal program is changed to High**

**NOTES**

- The **ID** column represents the order in which the programs are to be executed.
- The **Waiting in Q** column represents the amount of time the program has been waiting in the queue.



## 7.5.7 Accumulation in SCADA

Perform the following steps to reset accumulation counters:

**3. Tap the Reset Accumulation tab**

**1. Tap the SCADA button**

**2. Select Admin**

The screenshot shows the SCADA interface for 'Mainline 1'. The 'Accumulation' tab is selected. A table lists various devices with their accumulated values and reset options.

Device	# Number	Daily Accumulated	Total Accumulated	Last reset	Reset	Reset All Counters
Water Meter	—	186.2 m³	28454.1 m³	--	Reset	
Sub-Line WM	1	0.0 m³	0.0 m³	--	Reset	Reset All Counters
Dosing Meter	1	10.0 L	4500.0 L	10.12.2025   15:57	Reset	Reset All Counters
Pump	1	0.0 m³	0.0 m³	--	Reset	Reset All Counters
Valve	1	25.0 m³	4831.2 m³	--	Reset	Reset All Counters
Source A water meter	—	0.0 m³	0.0 m³	--	Reset	
Source B water meter	—	0.0 m³	0.0 m³	--	Reset	
Wells	1	0.0 m³	0.0 m³	--	Reset	Reset All Counters
Drain Meters	1	0.0 L	0.0 L	--	Reset	Reset All Counters

**4. Tap Reset**

The specific counter will be reset.

**5. Tap Reset All Counters**

All counters will be reset.



## 7.5.8 Sensors in SCADA

GrowSphere<sup>™</sup> by **NETAFIM** CS TEST Mainline 1 SCADA Simulation Sun 30 Mar 2025 10:20:45

General Valves Analytics Queue Accumulation **Sensors**

Pressure (0) **EC/pH (2)** Temperature (0) Humidity (0) Level (0) Soil moisture (0) General (1)

						Daily	
Sensor name	Date	Time	Value	Minimal	Maximal		
EC1.1	30.03.2025	10:20:45	1.90	0.00	0.00	Reset	
PH1.1	30.03.2025	10:20:45	5.30	0.00	0.00	Reset	

page 1 of page 1

1. Last sensor reading

2. Min/Max of the day



## Mainline

Display a general view and status of the hydraulics and the current running irrigation program.



## Sub mainline

The screenshot displays the GrowSphere MAX controller interface for 'Mainline 1'. The top navigation bar includes 'General', 'Shifts', 'Valves', 'Analytics', 'Queue', and 'Sensors'. The current view is 'Sub mainline' for the 'Avocado Hass - summer' program. The interface shows a horizontal mainline with six sub-mainline stations, each with a valve, pressure gauge, and flow meter. The status for each station is 00.0 Bar and 000.0 m3/h, with a nominal flow of 000.0 m3/h and 100 Valves. The total flow is 0000 / 0000 unit. The interface also shows the current temperature (19°C), date (Wed 13 Apr 2023), and time (12:30 AM). A sidebar on the left contains icons for Home, Program, Water, NPK, Dosing, Alarms, and Settings. A bottom navigation bar includes buttons for Mainline, Sub mainline, Shifts, Pump station, Filter station, and Dosing.

GrowSphere™ by NETAFIM

Controller name **Mainline 1**

19°C

Wed 13 Apr 2023 12:30 AM

**General** Shifts Valves Analytics Queue Sensors

Avocado Hass - summer

Skip Options Pause Mainline

Started: 11:00 | 13.04.23 | Shift: 12/22 | Total: 0000 / 0000 unit

Next: Avocado Hass - sum 13.04.23 | 11:00

Station	Pressure (Bar)	Flow (m3/h)	Nominal (m3/h)	Valves
1	00.0	000.0	000.0	100
2	00.0	000.0	000.0	100
3	00.0	000.0	000.0	100
4	00.0	000.0	000.0	100
5	00.0	000.0	000.0	100
6	00.0	000.0	000.0	100

Mainline Sub mainline Shifts Pump station Filter station Dosing



## Shifts

Presents current and next shifts

The screenshot displays the GrowSphere MAX SCADA interface. At the top, the 'Mainline 2' section is selected, and the 'Valves' tab is active. The interface shows two sections: 'Cooling valves' and 'Misting valves'. In the 'Cooling valves' section, the 'COOL2.1' valve is shown with a green indicator and a toggle switch that is currently turned on. In the 'Misting valves' section, the 'MIST2.2' valve is shown with a green indicator and a toggle switch that is currently turned on. The interface also includes a top navigation bar with 'Mainline 2' selected, a left sidebar with icons for home, valves, NPK, misting, alert, and settings, and a main content area with tabs for 'General', 'Valves', 'Analytics', 'Queue', 'Accumulation', and 'Sensors'. The 'Valves' tab is active, showing 'Cooling valves' and 'Misting valves' sections. The interface also shows a date and time of 'Tue 06 Jan 2026 13:52:47' and a battery level of 84%.



## Pump station

presents the pumps status and their nominal flow

**GrowSphere™** by **NETAFIM™** CS TEST **Mainline 2** SCADA Tue 06 Jan 2026 13:54:29

General Valves Analytics Queue Accumulation Sensors

Test IT Skip Options Pause Mainline

Started: 06.01.2026 | 12:30 | Shift: 2/2 00:24/01:00 | Total: 01:24/02:00 hh:mm | Next: Test IT 06.01.2026 | 14:00

show valves

Stand alone  
Nominal: 80.0 m<sup>3</sup>/h

1 M

0.0 m<sup>3</sup>/h  
Nominal: 40.0

Mainline Sub mainline Shifts Pump station Filter station Dosing



## Filter station

### Define the filter station parameters:

This screen display the currently status of the Filter Station

- **Active Filter:** Displays the active filter.
- **Filter Station Manual Operation:** Check the active filter station.
- **Test Filter Number:** Enter Filter number to test.
- **Pause / Stop / Start Filter:** Press pause, stop or start to control the filter station.
- **Reset Time & Quantity:** Press to reset time and quantity.

GrowSphere™ by NETAFIM

Controller name: **Mainline 1**

19°F

Wed 13 Apr 2023 12:30 AM

**General** | Valves | Analytics | Queue | Accumulation | Sensors

Avocado Hass - summer

Skip Options | Pause Mainline

Active Filter: **6/32**  
cycle start with filter 8

Pressure station manual operation  
 Filter station Active  
resume | Stop

Single filter testing  
test filter number: 1-32  
Start Filter

Next Cycle	Set	Left	DP	Set	Actual
Time	mm:ss	mm:ss	DP Sensor (Bar/PSI)	00.00	00.01
m3/THG	00.00	00.01			

Reset Time & Quantity

Mainline | Sub mainline | Shifts | Pump station | **Filter station** | Dosing



## Dosing

Monitoring view of the dosing operation including:

### Planned delivery

**Flow** - Actual flow per dosing channel

**Delivered (L)** - delivered quantity in Liter/ Galons

**Delivered (hh:mm)** - delivered amount of time when recipe is according to time.

**Open(%)** - percentage of time valve is open

**Method** - Fertilization method (Bulk, Spread, 1/1000, By Pulse)

**Tank level** - when using level sensor

**Agitator** - On/Off when using agitator

**EC/pH** - Target Vss. Actual.

**GrowSphere™ by NETAFIM** CS TEST **Mainline 2** SCADA Simulation Thu 08 Jan 2026 10:07:12

General Valves Analytics Queue Accumulation Sensors

Test IT Skip Options Pause Mainline

Recipe: npk2.1 Total: 00:07/02:00 hh:mm

Planned Flow (L/h) Delivered (L) Delivered (hh:mm) Open(%) Method Tank level Agitator

Planned	128.3	128.3	55.0	0.0		
Flow (L/h)	140.1	140.1	60.0	--		
Delivered (L)	4.8	4.8	2.0	0.0		
Delivered (hh:mm)	00:00	00:00	00:00	00:00		
Open(%)	35.0	35.0	40.0	0.0		
Method	1/1000	1/1000	1/1000	Spread		
Tank level	0 %	--	--	--		
Agitator	● OFF	--	--	--		

EC: Actual 1.1 Target 0.0  
pH: Actual 7.6 Target 0.0

Mainline Sub mainline Shifts Pump station Filter station **Dosing**



## 8. Misting, Cooling and Humidification

**1/** Misting, Cooling and Humidification settings

**4/** Cooling Program

**2/** Misting, Cooling and Humidification Program

**5/** Humidification Program

**3/** Misting Program

**6/** View programs



## 8.1 Misting, Cooling and Humidification settings

Select cooling and misting in the Mainline configuration screen.

The Misting program allows the operation of misting valves (foggers and or sprinklers) in dedicated settings and operation screens. The main parameters of the misting program are:

- Name of the program, Start, End, and On and Off times (cycles).
- The valves participating in this program can be selected from a pre-defined list.
- The valves will be activated according to the number of parallel vales settings: For example, if the parallel valves were set to 2, valves 1 and 2 will run together; after that, valves 3 and 4, etc. Then will be off for a defined time and will start a new cycle.
- There is an option to Start and Stop the program manually.

The screenshot shows the GrowSphere MAX interface for Farm Mainline 4. The 'Configuration' tab is selected, and the 'Mainline' sub-tab is active. The 'Valves' field is set to 6. The 'Cooling & Misting' option is checked and highlighted with a red box. Other options include Pump, Filter Station, and Dosing Station, which are currently unchecked. The 'Main Valve' option is also checked.



In the Cooling and Misting configuration tab:

The screenshot shows the configuration interface for Misting and Cooling & Humidification. The interface is divided into two main sections: Misting and Cooling & Humidification. The 'Cool & Mist' tab is selected in the top navigation bar. The settings are organized into two columns, one for Misting and one for Cooling & Humidification. The 'Number of valves in parallel' field is shared between both columns. The 'Pause irrigation during process' checkbox is also shared. The 'Required flow' field for Cooling & Humidification is currently set to 0.0 m<sup>3</sup>/h.

Parameter	Misting	Cooling & Humidification
Water source	main valve / pump	Pump Station
Number of valves	2	2
Required flow	0.0 m <sup>3</sup> /h	0.0 m <sup>3</sup> /h
Water source off delay	00:00 mm:ss	00:00 mm:ss
Pause irrigation during process	<input type="checkbox"/>	<input type="checkbox"/>
Number of valves in parallel	1	1
Overlapping between valves group		00:00 mm:ss

**1. Choose the water Source**

**4. Pause irrigation during misting / cooling process – Select if needed**

**7. Define overlapping between valve groups**

**3. Select Number of Cooling**

(humidification valves) and misting valves, If don't have leave it "0"

**2. Set the required flow rate**

(currently not active for alerts)

**5. Water source delay**

It is the Off delay for the water source

**6. Number of valves in parallel**

Set the number of valves to run together



In the Local digital output screen -

GrowSphere™ by NETAFIM Avri Farm Agit All Mainlines Settings Simulation 31.7°C Sun 25 Jun 2023 10:53:28

Configuration **Local I/O** Remote I/O Communication Wiring Diagram

Local digital output Local digital input Local analog input

Module	DO	Device type	NO.	Source	Name	Flow	Area	Assigned
DO573.1	7	Misting	1	M.Line1	MIST1.1	1.0 m³/h	—	Unassign
DO573.1	8	Misting	2	M.Line1	MIST1.2	2.0 m³/h	—	Unassign
DO573.1	9	Misting	3	M.Line1	MIST1.3	1.0 m³/h	—	Unassign
DO573.1	10	Misting	4	M.Line1	MIST1.4	1.5 m³/h	—	Unassign
DO573.1	11	Cooling	1	M.Line1	COOL1.1	1.0 m³/h	—	Unassign
DO573.1	12	Cooling	2	M.Line1	COOL1.2	1.0 m³/h	—	Unassign
DO573.1	13	Cooling	3	M.Line1	COOL1.3	1.5 m³/h	—	Unassign

AA < page 4 of page 5 >

1. Allocate the outputs for the misting and /or cooling valves (They can be allocated to Remote I/O).

2. Set the Flow rate as required.



Select the sensor for trigger:

The screenshot shows the GrowSphere MAX interface for 'Avri Farm Agit Mainline 1'. The 'Settings' menu is open to the 'Communication' tab. Under 'Communication', the 'Weather Station' option is selected. Below this, a status bar shows 'RS-232 (port 2)' with a green 'connected' indicator and a blue 'Unassign Weather station' button. A text box contains the following instruction:

For Cooling and Humidification programs, the sensor's Temperature / Humidity can be selected from the Davis weather station or local sensors.



## Set the analog sensor parameters

1. In the local analog input

The screenshot shows the 'Local I/O' configuration page for 'Local analog input'. The table below lists the configured sensors:

Module	AI	Device type	NO.	Source	Name	Input	Unit	Assigned
AI561.1	2	Fertilizer Tank level	1	M.Line2	FRTL2.1	4 - 20 mA		Unassign
AI561.1	3		0			4 - 20 mA		Unassign

Below the table, the 'Input Range (mA)' and 'Output Range' are configured as follows:

Input Range (mA): 4 - 20  
Output Range: 0 - 100  
Offset: 0.00

2. Set the analog input and the sensor range.



## 8.2 Misting, Cooling and Humidification Program

### 8.2.1 Create a new Cooling and misting program

1. Select a program to edit or create a new program. The total number of programs is 10 per mainline

The screenshot shows the GrowSphere MAX interface for configuring a misting and cooling program. The top navigation bar includes the GrowSphere logo, 'Farm', 'Mainline 4', and 'Misting and cooling' tabs. A status bar at the top right shows a warning icon, 'SD', the date 'Fri 20 Oct 2023', the time '11:11:34', and a signal strength indicator '87'. The main content area is a table with the following columns: Active ID, Name, Valves, Start - end time (hh:mm), ON time (hh:mm:ss), OFF time (hh:mm:ss), Above temp. (°C), Bellow RH (%), Temp sensor, and Hum sensor. A dropdown menu is open, showing 'Insert new program' options. The bottom navigation bar includes a home icon and a page indicator 'page 1 of page 2'.

Active ID	Name	Valves	Start - end time hh:mm	ON time hh:mm:ss	OFF time hh:mm:ss	Above temp. °C	Bellow RH %	Temp sensor	Hum sensor
	+ Insert new program								
	+ Insert new program								
	+ Insert new program								
	+ Insert new program								
	+ Insert new program								
	+ Insert new program								
	+ Insert new program								
	+ Insert new program								
	+ Insert new program								



1. Set the program Name

2. Select the control action

GrowSphere™ by NETAFIM CS TEST Mainline 1 Misting and cooling Simulation Mon 22 Dec 2025 16:41:35 79

Program 02 **Activate**

Control action	Start time	End time
Misting	00:00	00:00

ON time (hh:mm:ss)	OFF time (hh:mm:ss)	Cycle time (hh:mm:ss)
00:00:00	00:00:00	00:00:00

001

002

3. Cycle Time -

Added calculated cycle time to programs – Take into account the number of parallel valves



## 8.3 Misting Program

**1. Set the program active period Start time and End time**

**2. Set the vales On time and Off time cycle**

**3. Set the valves that participate on this program**

The vales will be activating according to the number of parallel vales settings. For example, if the parallel valves was set to 2, the valves 1 and 2 will run together for 50 seconds, after that valves 3 and 4 and followed by 5 and 6. Then will be off for 30 minutes. After 30 minutes will start a new cycle.

**4. Click 'Activate' to activate the program**



When the program is active then it is an option to Start the program manually!

When a cycle is running then will be an option to Stop it.

The screenshot shows the GrowSphere MAX control interface. At the top, the navigation bar includes the GrowSphere logo, 'CS TEST', 'Mainline 1', 'Misting and cooling', and 'Simulation'. A red warning triangle and an SD card icon are also present. The date and time are 'Mon 22 Dec 2025 16:41:35' and the signal strength is '79'. Below the navigation bar, there is a sidebar with icons for Home, Settings, Water, NPK, and Misting. The main area displays 'Program 02' with an 'Activate' button. Below this, there are three rows of controls: 'Control action' (Misting), 'Start time' (00:00), and 'End time' (00:00); 'ON time (hh:mm:ss)' (00:00:00), 'OFF time (hh:mm:ss)' (00:00:00), and 'Cycle time (hh:mm:ss)' (00:00:00); and a checkbox labeled '001'.



## 8.4 Cooling Program

### 3. Select the control period

### 6. Set the temperature to start the cycle.

The cycle will run when the temperature is above this value and the RH is below the RH set value.

### 7. Set the RH (Relative Humidity) value.

When the RH is below this value, the cycle will be permitted to start. When the RH is higher than this value will stop the cycle (also if the temperature is above the set value).

### 1. Set the program Name

### 2. Select the control action

### 5. Set the ON and Off time

### 8. Set the vales that participate on this program

### 9. Click 'Active' to activate the program

### 4. Select the control sensors

For example, the temperature Sensor is from the Davis WS and the Humidity is local

### 10. Cycle Time -

Added calculated cycle time to programs – Take into account the number of parallel valves



## 8.5 Humidification Program

### 3. Select the control period

### 6. Set the temperature to start the cycle.

The cycle will run when the temperature is above this value and the RH is below the RH set value.

### 7. Set the RH (Relative Humidity) value.

When the RH is below this value, the cycle will be permitted to start. When the RH is higher than this value will stop the cycle (also if the temperature is above the set value).

### 1. Set the program Name

### 2. Select the control action

### 5. Set the ON and Off time

### 8. Set the vales that participate on this program

### 9. Click 'Active' to activate the program

### 4. Select the control sensors

For example, the temperature Sensor is from the Davis WS and the Humidity is local

### 10. Cycle Time -

Added calculated cycle time to programs – Take into account the number of parallel valves

GrowSphere™ by NETAFIM

CS TEST Mainline 1 Misting and cooling Simulation

Mon 22 Dec 2025 16:49:36

Program 02 **Activate**

Control action: Humidification

Start time: 08:00 End time: 16:00 Above temp °C: 27.0 °C

Temp sensor: No Device

ON time (hh:mm:ss): 00:05:00 OFF time (hh:mm:ss): 00:30:00 Cycle time (hh:mm:ss): 00:40:00

Below RH %: 40.0 % Hum sensor: No Device

001  008

002

003

004

005

006

007



## 8.6 View programs

The Programs screen shows the active programs and the settings.

When one of the programs is running (valves are open) then will be uplighter to blue

Active	ID	Name	Valves	Start - end time hh:mm	ON time hh:mm:ss	OFF time hh:mm:ss	Above temp. °C	Bellow RH	Temp sensor	Hum sensor
<input checked="" type="checkbox"/>	1	Program 01	6	10:00 - 15:00	00:00:50	00:30:00	0.0 °C	0.0 %		
<input checked="" type="checkbox"/>	2	Cooling B12	4	15:00 - 18:00	00:02:00	00:45:00	34.0 °C	55.0 %	W. station	Local
<input checked="" type="checkbox"/>	3	Humid c2	6	06:00 - 10:00	00:01:30	01:00:00	25.0 °C	65.0 %	Local	Local
+ Insert new program										
+ Insert new program										
+ Insert new program										
+ Insert new program										
+ Insert new program										



GrowSphere™ by NETAFIM™ Farm Mainline 1 SCADA Simulation Wed 13 Apr 2023 12:30 AM

General Valves Analytics Queue Accumulation Sensors

Program 01 Skip Options Pause Mainline

Started: 08.04.2024 | 10:11 | Shift: 1/1 04:01/10:00 | Total: 04:01/10:00 mm:ss | Next: Program 01 08.04.2024 | 10:25

ON 00:05 mm:ss

SLv1.1 64% SLv1.2 74%

100% 0%

N P K Acid

1 2 3 4

FLOW QTY

Planned

pH EC

5.4 1.7

Target 0.0 Target 0.0

4.8 -/3 4.6

Bar Bar

50.0 m³/h

Nominal 50.0

Target 0.0 Target 0.0

Mainline Sub mainline Shifts Pump station Filter station Dosing

When one of the programs is running, at the Scada Screen will show that the valves are ON



## Cooling and misting valves in SCADA

The screenshot displays the GrowSphere SCADA interface for 'Mainline 2'. The top navigation bar includes 'General', 'Valves', 'Analytics', 'Queue', 'Accumulation', and 'Sensors'. The 'Valves' section is active, showing filters for 'All', 'Alert', 'Manual', 'Not assigned', and 'Cooling & misting'. The 'Cooling valves' section contains two toggle switches: 'COOL2.1' (off) and an unlabeled one (off). The 'Misting valves' section contains two toggle switches: 'MIST2.1' (off) and 'MIST2.2' (on). The interface also shows a sidebar with various icons and a top status bar with 'Simulation', a warning icon, 'Tue 05 Aug 2025 15:57:35', and a signal strength indicator.



## 9. Dosing Other settings

**1/** Agitator Settings

**2/** Set agitators operation

**3/** Set Sub-station



## 9.1 Agitator Settings

Agitators are devices that mix the media to be metered homogeneously, especially in the case of powdery additives or liquids that are challenging to dilute. The main features of the Agitators program are:

- Automatically defined Dosing Tanks according to the number of Dosing channels in the system.
- Each dosing channel has a Dosing tank that can be selectively activated or deactivated.
- Agitator can be signed to the I/O module and port in the controller and allocated to RTU.
- Number of agitators can be activated simultaneously.
- Day and night operation times for the agitator's activity can be set.
- ON and Off time for agitators can be set During Fertigation and not delays.

In the Mainline configuration screen –  
Ensure the Dosing station is selected.

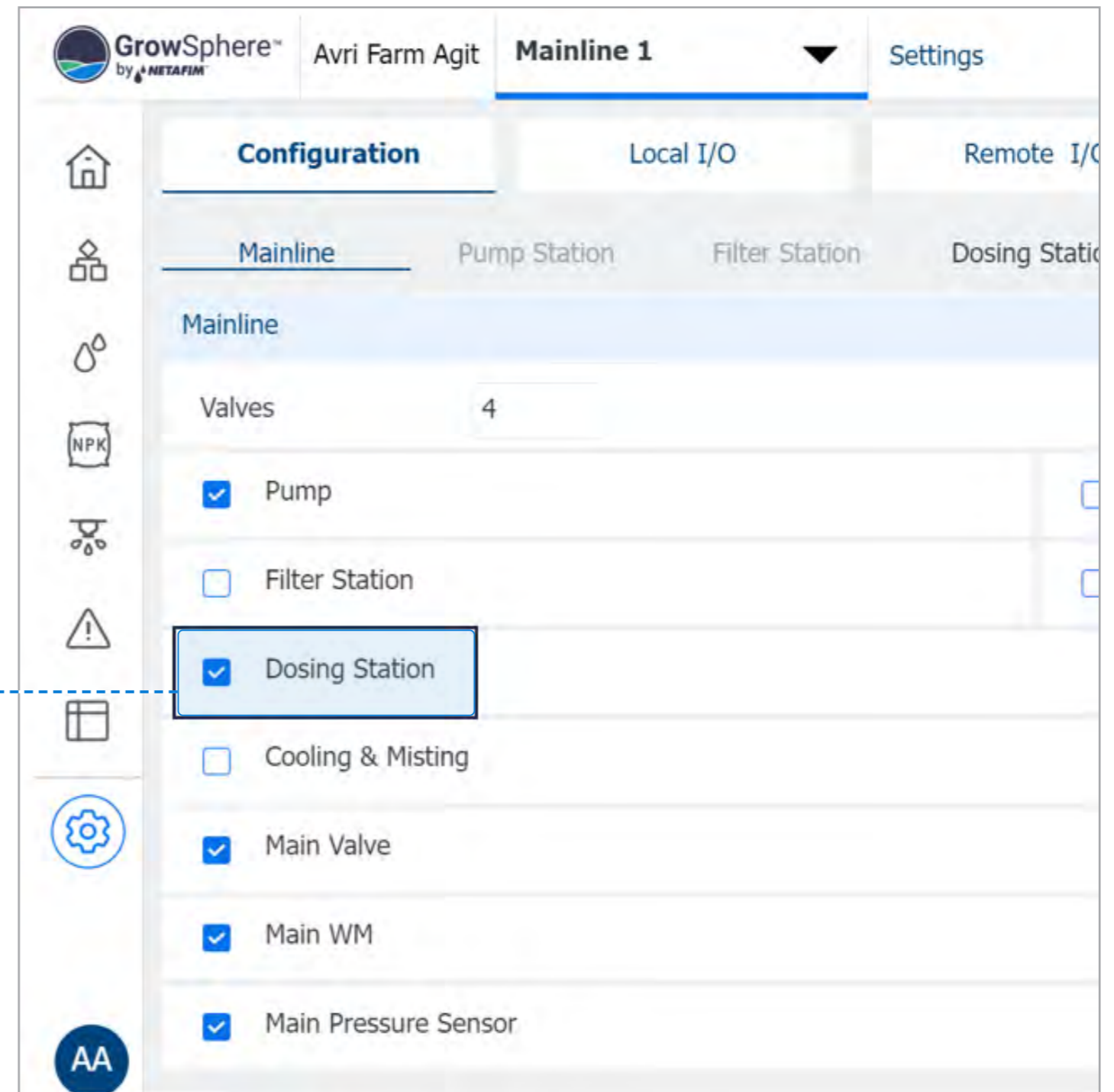

## Assign dosing channels and agitators

1. In the Dosing station configuration screen

Select the Dosing Channels (tanks) that have Agitator

GrowSphere™ by NETAFIM

CS TEST Mainline 2 Settings Simulation Tue 05 Aug 2025 15:59:05 97

Mainline Configuration Control Configuration Local I/O Remote I/O Communication Wiring Diagram

Mainline Sub-Mainlines Pump Station Filter Station **Dosing Station** Cool & Mist Valves Other Devices

Dosing Station

Extensive  Intensive

Dosing Channels   Mixing valve / PRE EC control

CH	1	2	3	4	5	6	7	8
Dosing meter	<input type="checkbox"/>	<input type="checkbox"/>	<input type="checkbox"/>	<input type="checkbox"/>				
Agitator	<input checked="" type="checkbox"/>	<input type="checkbox"/>	<input type="checkbox"/>	<input type="checkbox"/>				
Fert tank level	<input checked="" type="checkbox"/>	<input checked="" type="checkbox"/>	<input checked="" type="checkbox"/>	<input checked="" type="checkbox"/>				

Dosing Booster  Booster Pump O.L.

Dosing Pressure switch  Agitator pump

EC sensors  pH sensors

2. Select when there is a Main Agitator Pump



## Allocate agitator outputs

Agitator can not be assigned to RTU.

GrowSphere™ by NETAFIM CS TEST All Mainlines Settings Simulation Tue 05 Aug 2025 16:02:40

Mainline Configuration Control Configuration **Local I/O** Remote I/O Communication Wiring Diagram

Local digital output Local digital input Local analog input

Module	DO	Device type	NO.	Source	Name	Flow	Area	Assigned
DO573.1	8	Dosing Channel	3	D.Statio1	DCH1.3	50.00 L/h	—	Unassign
DO573.1	9	Dosing Channel	4	D.Statio1	DCH1.4	600.00 L/h	—	Unassign
DO573.1	10	Pump	1	M.Line2	PMP2.1	70.00 m³/h	—	Unassign
DO573.1	11	MainValve	1	M.Line2	MVLV2.1	—	—	Unassign
DO573.1	12	Sub Main valve	1	M.Line2	SUBMV2.1	—	—	Unassign
DO573.1	13	Sub Main valve	2	M.Line2	SUBMV2.2	—	—	Unassign
DO573.1	14	<b>Assign</b>	0			—	—	Unassign

page 3 of page 9 Expansion box

Valve (0) Dosing Booster (0) Condition active (0)

MainValve (0) Normal Alarm (4) EC Pre-Control open (1)

Pump (0) Selector (0) EC Pre-Control close (1)

Filter (1) Agitator (5) Relay (0)

Main Filter Valve (0) Cooling (1) Same as DO

Dosing Channel (1) Misting (0) EC Pre-Control pump (1)

Mist Main valve / pump (1) Cool Main valve / pump (1) Agitator Pump (0)

Sub Main valve (0) Critical Alarm (4) Well Pump (1)



## 9.2 Set agitators operation

1. Select Tanks

2. Turn agitator ON

GrowSphere™ by NETAFIM™ CS TEST Mainline 1 Dosing Simulation Sun 31 Aug 2025 11:31:49

Recipes Overview User Overview Technician General Settings Channels Settings

EC pH control Mixing valve Tanks Agitators

ID	Tank name	Tank volume	Tank height	Tank Top diameter	Conical tank	Level in tank	ACT CONTENT L	ACT CONTENT %	Agitators	Level sensor
1	T1	1000L	--	--	<input type="checkbox"/>	0 %	0.0L	0.0	<input checked="" type="checkbox"/>	--
2	T2	1000L	--	--	<input type="checkbox"/>	--	--	--	<input type="checkbox"/>	--
3	T3	1000L	--	--	<input type="checkbox"/>	--	--	--	<input type="checkbox"/>	--
4	--	0L	--	--	<input type="checkbox"/>	--	--	--	<input type="checkbox"/>	--



**1. Select Agitators**

**4. Set the ON and Off time for the mixing period**

**2. Define the number of agitators work in parallel**

**3. Set the parameters for the Night activity**

The screenshot shows the 'Agitators' configuration page in the GrowSphere MAX interface. The page title is 'Avri Farm Agit Mainline 1' and the current view is 'Dosing'. The navigation menu includes 'Recipes', 'Overview User', 'Overview Technician', 'General Settings', and 'Channels Settings'. The 'Agitators' tab is selected, showing a 'Number of agitators work in parallel' field set to 2. Below this is a table for defining activity periods:

Function	Start time	End time mm:ss	ON time mm:ss	OFF time
Day Period	08:00	16:00	00:05	00:30
Night Period	16:00	08:00	00:05	01:30
When Fertigation is ON			00:03	00:10



## 9.3 Setting the sub station

- Go to the communication TAB, Sub-Dosing station and check if the system is in communication with the substation.

The screenshot displays the GrowSphere MAX web interface. At the top, the controller name is 'Mainline 1', the temperature is 19°F, and the date/time is Wed 13 Apr 2023 12:30 AM. The 'Communication' tab is selected, and the 'Sub-Dosing station' sub-tab is active. A dialog box titled 'Sub Dosing Station Configuration' is open, showing the following details:

- Dosing Station IP: 192.168.0.11
- Assign remote station to: Mainline 1 (selected in a dropdown menu)
- \*Note: the remote station controller's IP will be assigned according to the chosen mainline. this operation will reset the remote controller

Buttons for 'Cancel' and 'Set & Allocate' are visible at the bottom of the dialog box. In the background, a table lists four mainlines, with the third one (Mainline 3) marked with a green checkmark, indicating it is the selected mainline for the sub-dosing station.



- If the substation is not in communication, press the “set and allocate”

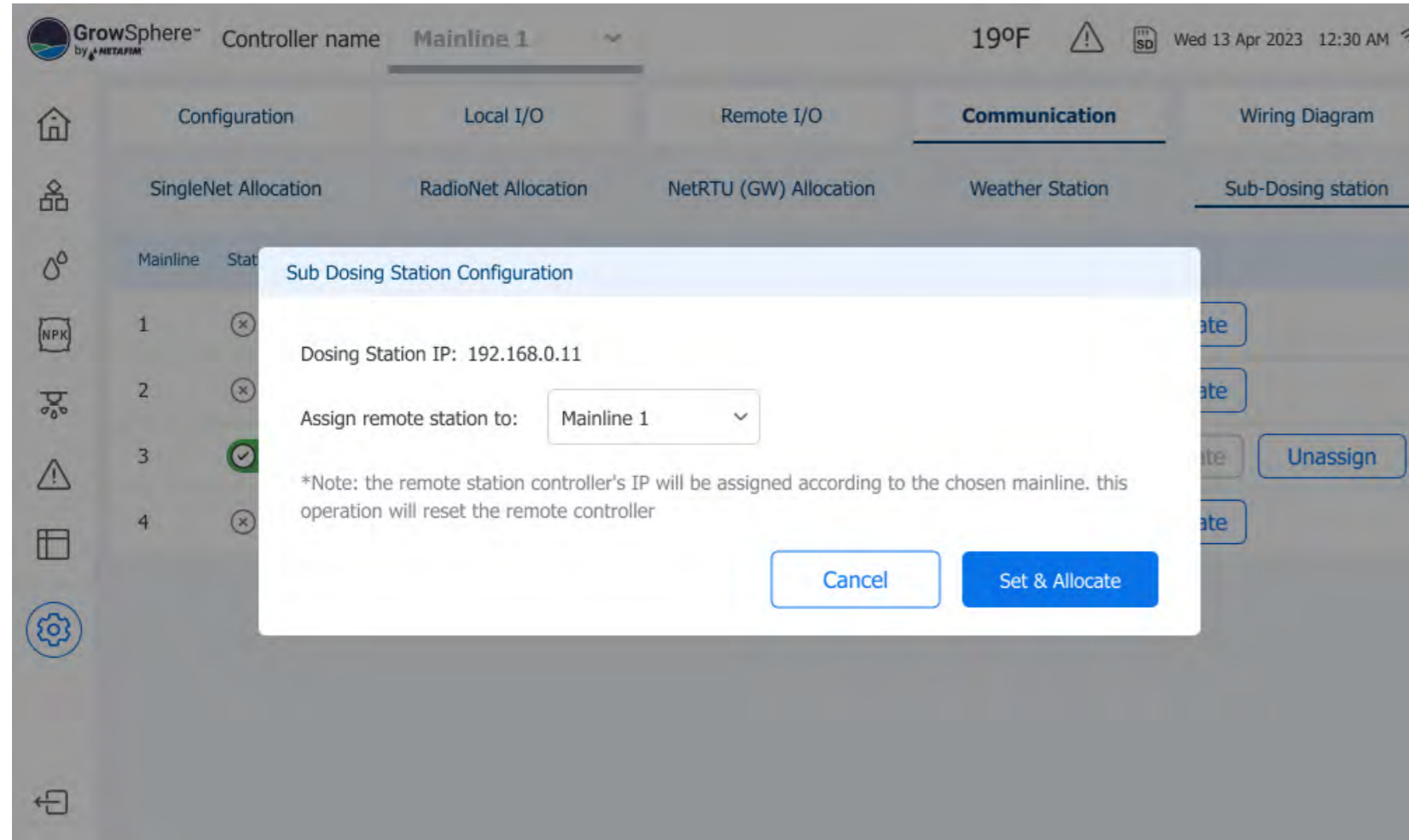

- Once the “Connected” appear as in the below image, the connection process is done.

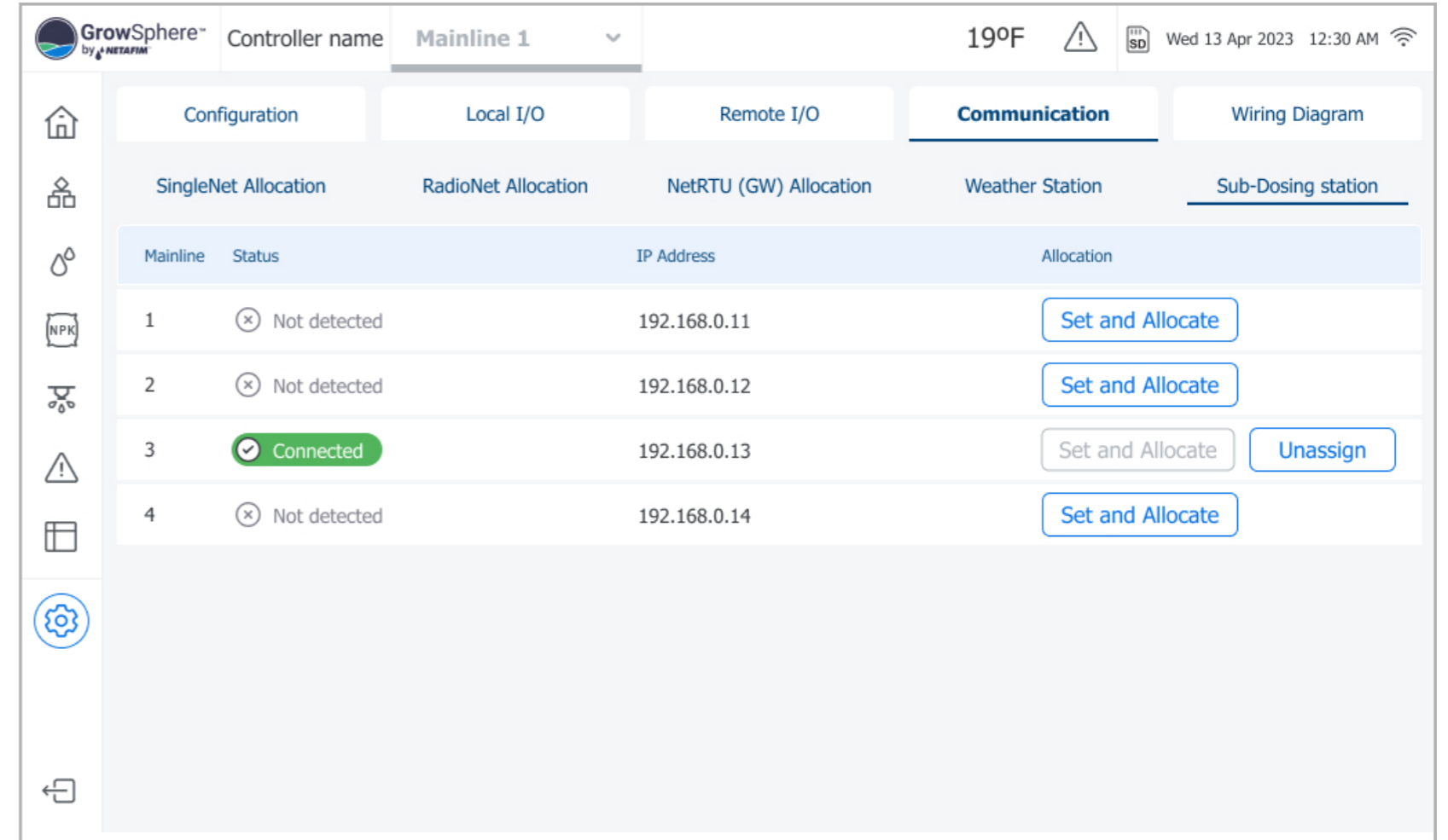

- To start the Autotune process, select"
  - The participating pump
  - Participating irrigation valves
  - Participating dosing channels

At the end of step [3] activate the Autotune.

**Dosing channel valve type, currently only PWM is supported**

**Enable when close loop mechanism is fully working. Disable when Ultra sonic DM is missing.**

**Test= open individual dosing valve for 1 minute, to verify correct wiring and valve is functioning.**

**Percentage of valve opening for flow correction**

**Line stabilization time for the auto tune process, dosing channels will open after the specified delay. Pump and valves will open before.**

**Dosing channel flow distance from target, out of this range the valve will make a correction.**



- Select the required pump and press DONE.

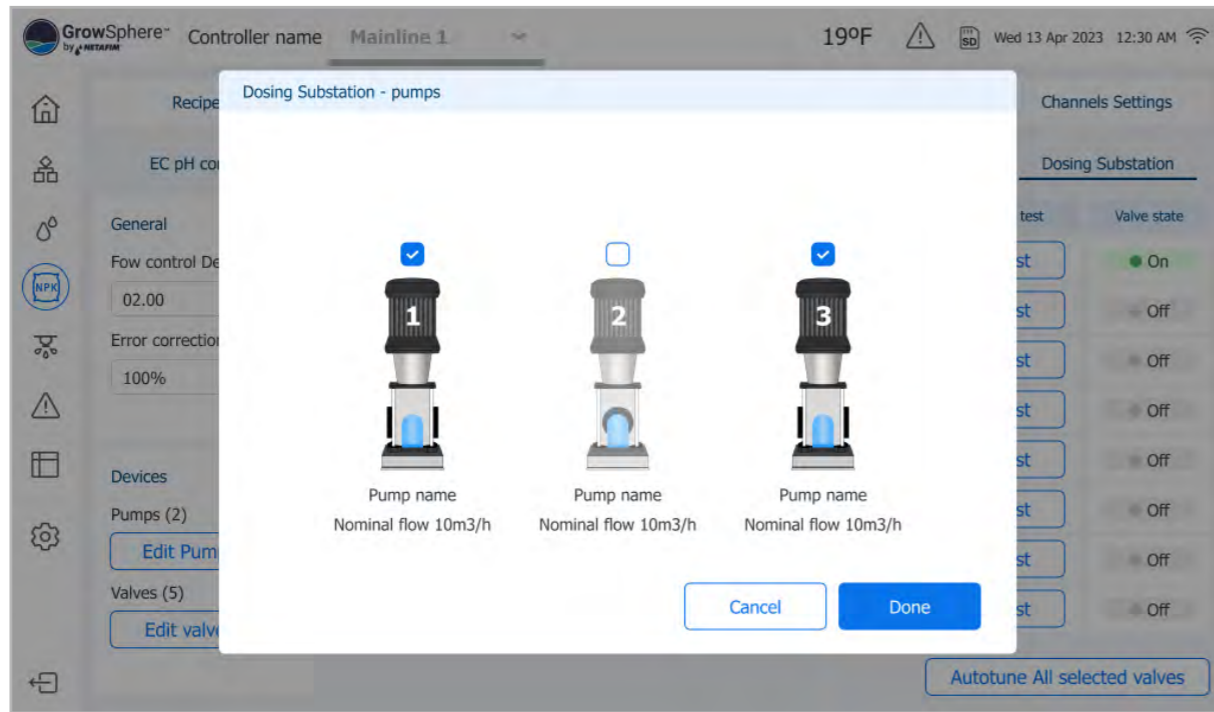

- Select the required irrigation valves and press DONE

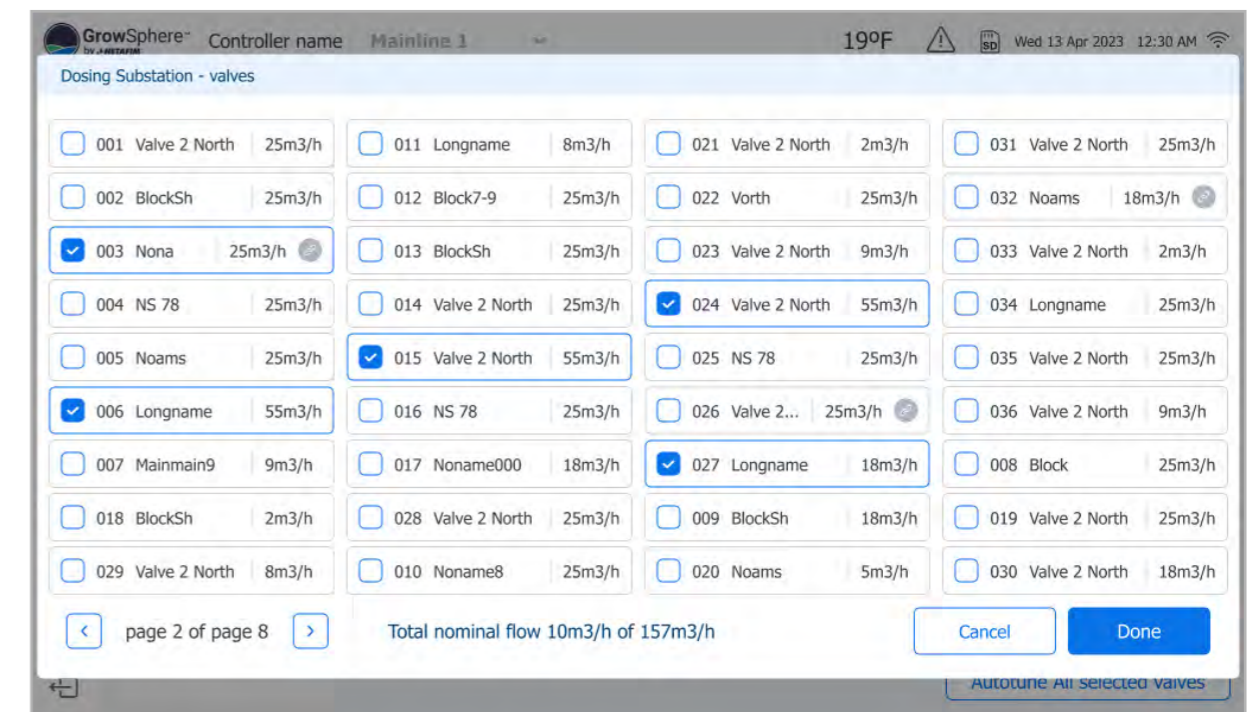

- Select the required dosing channels and start the Autotune.

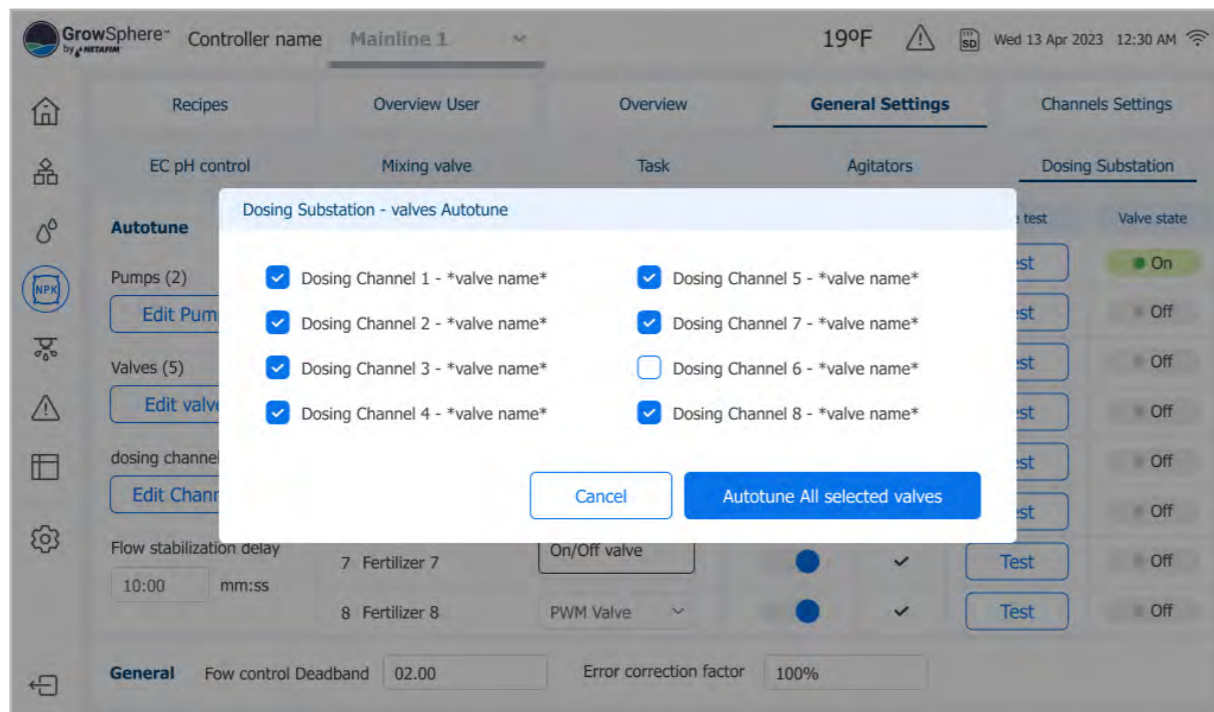

- If you wish to stop the Autotune process, press on Stop Autotune button.

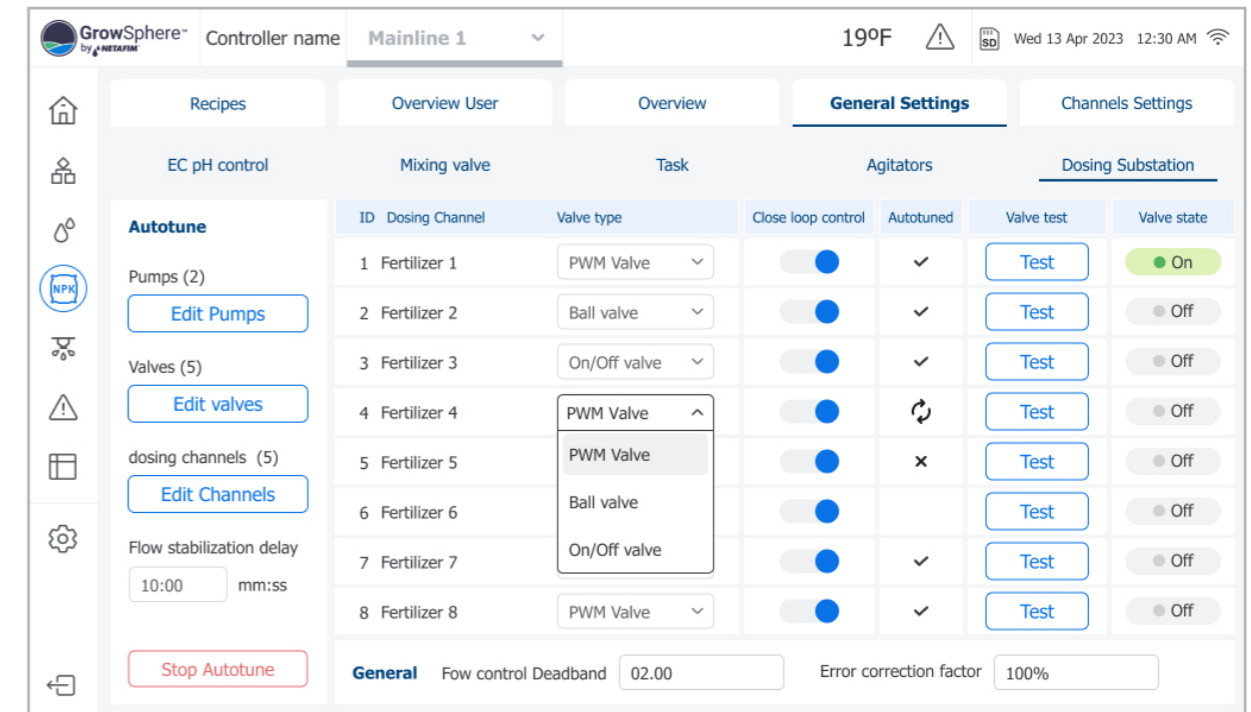

## 10. Conditions & Triggers

**1/** Conditions to start the Irrigation Program by external triggers.

**2/** Triggers definition

**3/** Settings of Analog trigger - Sensors

**4/** Trigger irrigation

**5/** General triggers



## 10.1 Conditions to start the Irrigation Program by external triggers.

To activate the irrigation program, external triggers need to be identified. The user can select the trigger type, which could be a dry contact or an analog sensor, and specify a condition to start the program.

The conditions can be of type and value, which determine when to start or stop the program.

The program types available are Only if ON, One Shot, and Multi Shot.

In all options, an emergency switch (DI dry contact) can be used to stop the program if needed.

A general sensor, such as a tank-level sensor, can also be selected. The sensor must be 0-20mA.



## 10.2 Triggers definition

1. The user / technician will define the triggers that have on his system.

2. The triggers can be digital or analog. Select and set the following steps.

4. Choose Dry contact

Module	DI	Device type	NO.	Source	Name	Type	Rate	Assigned
PM5052	0	Water Meter	1	M.Line1	WMTR1.1	LPP	10.00	Unassign
PM5052	1	Dosing Meter	1	D.Statio1	DMTR1.1	LPP	10.00	Unassign
PM5052	2	Dosing Meter	2	D.Statio1	DMTR1.2	LPP	10.00	Unassign
PM5052	3	Dosing Meter	3	D.Statio1	DMTR1.3	LPP	10.00	Unassign
PM5052	4	Dosing Meter	4	D.Statio1	DMTR1.4	LPP	10.00	Unassign
PM5052	5	Fertilizer Tank Lov	1	M.Line2	FRTL02.1	NO	—	Unassign
PM5052	6	Assign	0			—	—	Unassign

3. Choose the digital input where the Dry Contact is connected.



1. Click to edit the name of the Dry contact, example Dry OFF

GrowSphere™ by NETAFIM

CS TEST All Mainlines Settings

Mainline Configuration Control Configuration **Local I/O** Remote I/O Communication

Local digital output Local digital input Local analog input

Module	DI	Device type	NO.	Source	Name	Type	Rate
PM5052	0	Water Meter	1	M.Line1	WMTR1.1	LPP	10.00
PM5052	1	Dosing Meter	1	D.Statio1	DMTR1.1	LPP	10.00
PM5052	2	Dosing Meter	2	D.Statio1	DMTR1.2	LPP	10.00
PM5052	3	Dosing Meter	3	D.Statio1	DMTR1.3	LPP	10.00
PM5052	4	Dosing Meter	4	D.Statio1	DMTR1.4	LPP	10.00
PM5052	5	Fertilizer Tank Lov	1	M.Line2	FRTL02.1	NO	—
PM5052	6	Assign	0			—	—

page 1 of page 2

Device name (Up to 8 characters) Dry OFF

1 2 3 4 5 6 7 8 9 0 - =

q w e r t y u i o p

a s d f g h j k l

z x c v b n m , . /

# += Space

OK

2. Select the DI type normally open or normally close.



## 10.3 Settings of Analog sensors

Module	AI	Device type	NO.	Source	Name	Input	Unit	Assigned
AI561.1	2	Fertilizer Tank level	1	M.Line2	FRTL2.1	4 - 20 mA		Unassign
AI561.1	3		0			4 - 20 mA		Assign

**1. Select Local analog Inputs**

**2. Select the AI where the sensor is connected**

**3. Choose the sensor type.**

For example, if it is a sensor level, choose General 0-5 V



## Settings of Analog triggers – Sensors

### 4. Edit the sensor Name. For example, Low Level

The screenshot displays the GrowSphere MAX interface for configuring sensors. The top navigation bar includes 'Farm - Trigger', 'All Mainlines', 'Settings', and 'Simulation'. The 'Local I/O' tab is selected, and the 'Local analog input' section is active. A table lists sensor configurations:

Module	AI	Device type	NO.	Source	Name
AI561.1	0	General 0-20mA	2	M.Line1	GENAI1.2
AI561.1	1	General 0-20mA	1	M.Line1	Level 1

Below the table, the 'Input Range (mA)' and 'Output Range' are configured for the selected sensor. The input range is set to 4 - 20 mA, and the output range is 0 - 100. An 'Unassign' button is visible next to the configuration.

A modal dialog titled 'Device name (Up to 8 characters)' is open, showing a virtual keyboard with 'Low Level' entered. A callout points to the 'Input Range (mA)' field in the second row of the table, indicating step 5.

### 5. Set the sensor range



## Type - Only if ON

1. The program types are: Only if ON , One Shot and Multi Shot.
2. The external triggers are set as a condition to activate the irrigation program.
3. The user will choose the trigger type, dry contact or analog sensor, and the condition to start the program.
4. The conditions are type and trigger to start or stop the program.
5. The program has two periods, each period has an independent Start time, End time and triggers.
6. For Only if ON condition can be selected Trigger ON.
7. Emergency switch (DI dry contact) is a DI switch to stop the program when it is active or prevent it from being activated.

Example of Condition Only If On

With storage tank and One float (N.O. Switch)

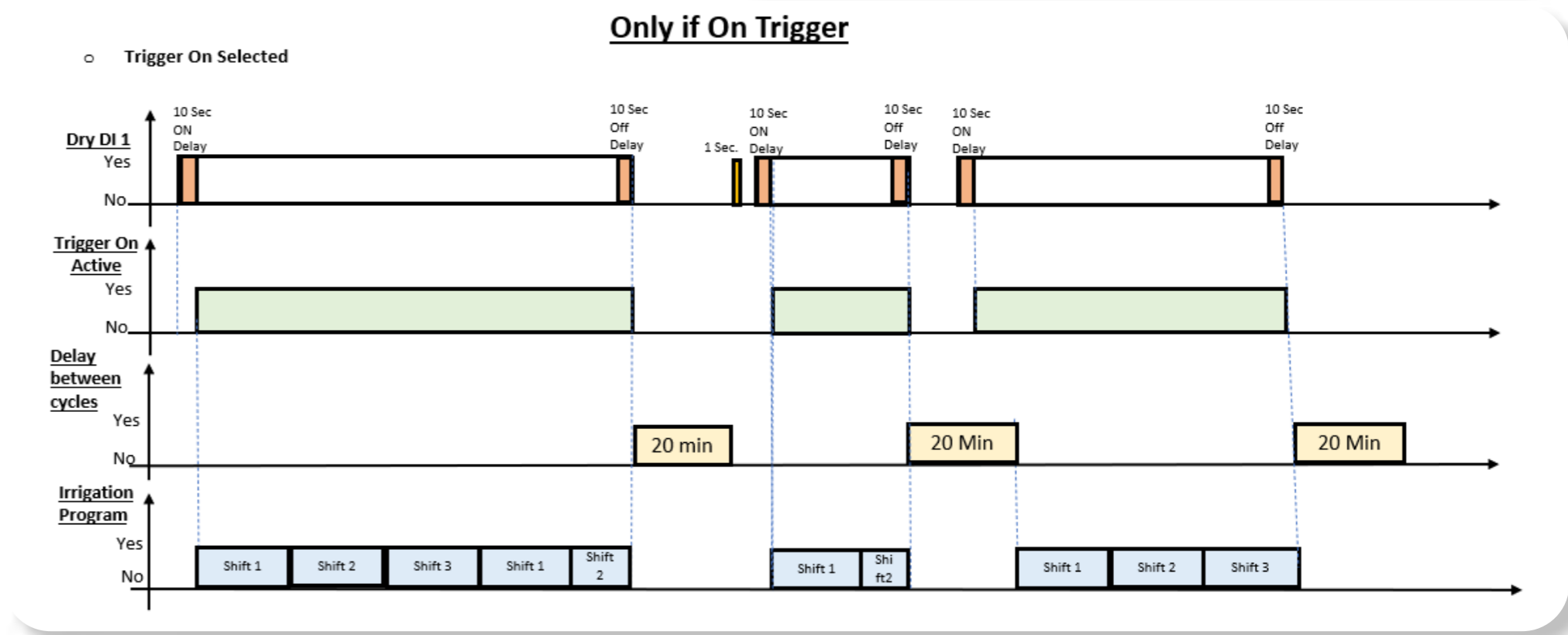
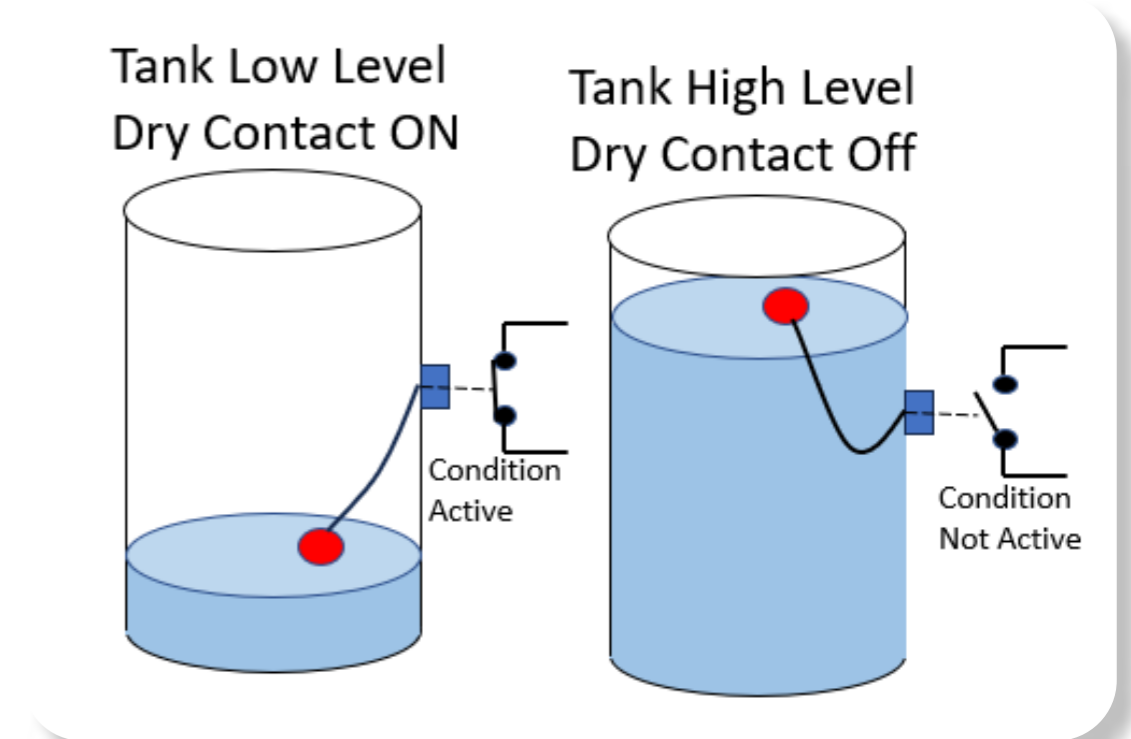

## 10.4 Define irrigation by conditions

- Edit the condition and chose relevant netacap sensor.

- Select “Analog” type condition.
- All sensors related to the netacap will appear as trigger options for the program.
- Set up the on and off thresholds.

The screenshot shows the 'Trige' irrigation program configuration in the GrowSphere MAX interface. The top navigation bar includes 'GrowSphere by NETAFIM', 'CS TEST', 'Mainline 2', 'Irrigation', 'Simulation', and a warning icon. The main area is divided into several sections:

- Program Info:** Type: Routine, Amount (shift): 00:30, Factor: 100%, Total: 00:30 | 20.00 m³, Last irrigation: None, Next irrigation: 09.01.2026 | 06:00.
- Start times:** A table with columns for Time period, Trigger, and Actual. One entry is checked for 06:00 - 16:00 with 'ON - No device' trigger.
- Conditions:** A dropdown menu currently set to 'Conditions'.
- Schedule:** Set to 'Every (X) days' with '1 day' selected.
- Water before & after:** Apply To: Per shift, Before: 00:00, After: 00:00.

The screenshot shows the 'Period 1 - settings' dialog box. It has radio buttons for 'Analog' (selected) and 'Digital'. Below are fields for 'Active', 'Start time' (00:01), 'End time' (23:25), 'Type' (Multi Shot), 'Trigger ON' (No Device), 'Value' (> 20.0), 'Trigger OFF' (No Device), and 'Value' (< 10.0). A red box highlights a grid of sensor options:

NC1WC1	NC1WC2	NC1WC3	NC1WC4	NC1WC5
NC1WC6	NC1ST1	NC1ST2	NC1ST3	NC1ST4
NC1ST5	NC1ST6	NC1AT1		

Buttons for 'Unassign' and 'Done' are visible at the bottom right.



- Program is triggered by netacap sensor.
- Actual value from sensor can be seen.

The screenshot displays the 'Irrigation' configuration page for 'Mainline 1'. At the top, there's a navigation bar with 'Govrinit', 'Mainline 1', and 'Irrigation'. A red warning icon with the number '2' is visible. The main area is divided into several sections:

- Triger:** A dropdown menu and an 'Activate' button.
- General Settings:** Type (Routine), Priority (Normal), Unit (HH:MM), Amount (shift) (00:30), Factor (100%), Total (00:30 | 0.00 m³), Last irrigation (None), and Next irrigation (09.01.2026 | 08:00).
- Start times:** A table with columns for Time period, Trigger, and Actual.
 

Time period	Trigger	Actual
<input checked="" type="checkbox"/> 08:00 - 16:00	ON - ● NetaSense<30 OFF - ● NetaSense>70	
<input type="checkbox"/> 00:00 - 00:00	ON - No device OFF - No device	
<input type="checkbox"/> Emergency OFF Switch	No device	
- Date range:** 23.12.25, No end (checked).
- Schedule:** Every (X) days, 1 day.
- Water before & after:** Apply To (Per shift), Before (00:00), After (00:00), HH:MM.



## 10.5 General triggers

### Digital Input (Dry Contact)

1. Select Conditions

2. Select the Edit icon to edit the 1st Time Period. The same settings are for the 2nd Time Period. The start and end times can not be overlapping between periods.

The same settings are for Period Two. The start and end times can not be overlapping between periods.



## Digital Trigger

**1. Select Digital  
(for dry contact DI)**

**3. Choose the  
type Only if ON**

Period 1 - settings

Analog  Digital

Active	Start time	End time	Type	Trigger on	Trigger off
<input type="checkbox"/>	00:00	00:00	Only if On	No Device	No Device

Only if On  
Only if On  
One Shot  
Multi Shot

Done

**2. Select the checkbox for  
activating the condition**

**4. Select the trigger,  
In this example Dry ON**

**5. To unassigns the  
trigger that was selected**

Period 1 - settings

Analog  Digital

Active	Start time	End time	Type	Trigger on	Trigger off
<input checked="" type="checkbox"/>	08:00	14:00	Only if On	Dry ON	No Device

Emrgcy Dry ON DRYC1.4 Low Swch

Unassign

Done



## Only if ON - Digital Trigger

**1. Click on Settings**

**2. ON delay: it is a time that the DI must be ON to be an active trigger (mm ss)**

**3. Off delay: it is a time that the DI must be Off to be a not active trigger (mm ss)**

**4. It is a minimal time between cycles ; when the trigger turns OFF and ON again the program will start after this delay. (mm:ss)**



Only if ON - Digital Trigger

The screenshot shows the 'Program 01' configuration page in the GrowSphere MAX software. The top navigation bar includes 'Farm - Trigger', 'Mainline 1', 'Irrigation', and 'Simulation'. A status bar at the top right shows the date 'Sun 27 Aug 2023 12:51:13' and a battery level of 81%. The main content area is divided into several sections:

- Program Header:** 'Program 01' is displayed in a text box. To its right, the text 'Program not activate!' is shown. A prominent blue 'Activate' button is located on the right side of this section.
- Program Details:** This section contains several input fields and buttons:
  - Type: Routine (dropdown)
  - Amount (shift): 10:00 (text input)
  - Factor: 100% (text input)
  - Total: 30:00 | 14.50 m³ (text input)
  - Priority: Normal (dropdown)
  - Unit: MM:SS (dropdown)
  - Buttons: Shifts (3), Dosing, Prop 1, Settings
  - Last irrigation: None
  - Next irrigation: None
- Start times and Conditions:** A table with columns 'Time period', 'Trigger', and 'Actual'.
 

Time period	Trigger	Actual
<input checked="" type="checkbox"/> 08:00 - 14:00	ON - <input type="radio"/> Dry ON OFF - <input type="radio"/> No device	
<input type="checkbox"/> 00:00 - 00:00	ON - <input type="radio"/> No device OFF - <input type="radio"/> No device	
- Date range:** 27.08.23 to 27.08.23, with a 'No end' checkbox.
- Schedule:** 'Every (X) days' dropdown set to '1 day'.
- Water before & after:**
  - Apply To: Per shift (dropdown)
  - Unit: HH:MM (dropdown)
  - Before: 00:00 (text input)
  - After: 00:00 (text input)

1. Activate the program



2. When the condition is ON, and it is on the period window the program will be posted to the Queue to be activated.

GrowSphere™ by NETAFIM™ Farm - Trigger Mainline 1 Irrigation Simulation Sun 27 Aug 2023 12:52:23

Program 01 Skip Options Pause Mainline

Type Routine Amount (shift) 10:00 Factor 100% Total 30:00 | 14.50 m³ Last irrigation 27.08.23 | 12:52

Priority Normal Unit MM:SS Shifts (3) Dosing Prop 1 Settings Next irrigation None

Start times Conditions Date range 27.08.23 27.08.23 No end

Time period	Trigger	Actual
<input checked="" type="checkbox"/> 08:00 - 14:00	ON - <input checked="" type="radio"/> Dry ON OFF - <input type="radio"/> No device	
<input type="checkbox"/> 00:00 - 00:00	ON - <input type="radio"/> No device OFF - <input type="radio"/> No device	

Schedule Every (X) days 1 day

Water before & after

Apply To	Unit	Before	After
Per shift	HH:MM	00:00	00:00

Emergency OFF Switch Emrgcy



## Only if ON - Analog Input

### Example: Condition Only If On with Analog Sensor Level

The set point is 30

When the Tank level is lower than 30 then the Irrigation program will run.

When the tank level is higher than 30, the irrigation program will stop.

**1. Select Analog** (Highlighted button for Analog and written as Digital)

**2. Select the start and End times** for the period the condition will be active

**3. Choose the type Only if ON**

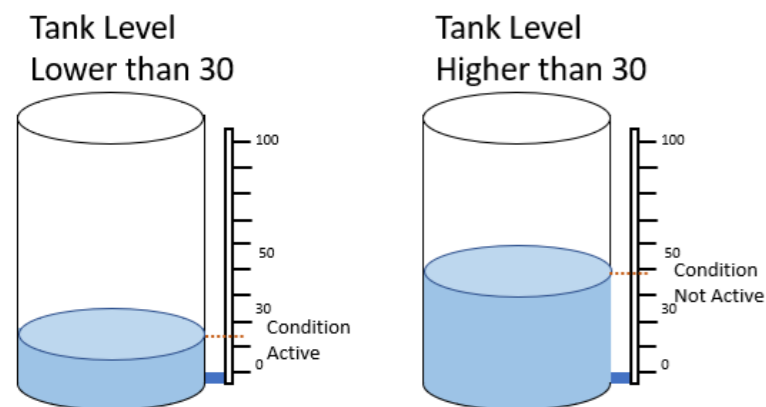

Period 1 - settings

Analog  Digital

Active	Start time	End time	Type	Trigger on	Value	Trigger off	Value
<input checked="" type="checkbox"/>	08:46	15:00	Only if On ▼	No Device	< 30.0	No Device	> 30.0

Done

Only if ON Digital Trigger.

2. Actual is the actual value of the sensor.

3. Select Activate to make the program activate.

1. These value is the target trigger to activate the irrigation program

GrowSphere™ by NETAFIM™ Farm - Trigger Mainline 1 Irrigation 33.6°C Sun 03 Sep 2023 11:43:25

Program 04 Program not activate! **Activate**

Type: Routine Amount (shift): 03:00 Factor: 100% Total: 06:00 | 3.00 m³ Last irrigation: None

Priority: Normal Unit: MM:SS Shifts (2) Dosing prop Settings Next irrigation: None

Start times Conditions

Time period	Trigger	Actual
<input checked="" type="checkbox"/> 08:46 - 15:00	ON - Tank 1 < 30 OFF - Tank 1 > 30	
<input type="checkbox"/> 00:00 - 00:00	ON - No device OFF - No device	
<input type="checkbox"/> Emergency OFF Switch	No device	

Date range: 03.09.23 - 03.09.23 No end

Schedule: Every (X) days 1 day

Water before & after: Apply To: Per shift Unit: HH:MM Before: 00:00 After: 00:00



5. When the sensor value is lower than the target, the program will be posted in the Queue.

4. When it is a running program then will wait to be send to the hydraulic manager to run this program.

**GrowSphere™** by **NETAFIM™** Farm - Trigger **Mainline 1** Irrigation 33.3°C Sun 03 Sep 2023 12:02:50

Program 04 Waiting in queue Start

Type: Routine Amount (shift): 03:00 Factor: 100% Total: 06:00 | 3.00 m³ Last irrigation: None

Priority: Normal Unit: MM:SS Shifts (2) Dosing prop Settings Next irrigation: None

Start times Conditions Act. Tank 1: 29 Date range: 03.09.23 - 03.09.23  No end

Time period	Trigger	Actual
<input checked="" type="checkbox"/> 08:46 - 15:00	ON - ● Tank 1 < 30 OFF - ● Tank 1 > 30	On
<input type="checkbox"/> 00:00 - 00:00	ON - No device OFF - No device	
<input type="checkbox"/> Emergency OFF Switch	No device	

Schedule: Every (X) days, 1 day

Water before & after: Apply To: Per shift, Unit: HH:MM, Before: 00:00, After: 00:00



### Example: Condition Only If On with Analog Sensor Level

The set point is 30

When the Tank level is lower than 30 then the Irrigation program will run.

When the tank level is higher than 30, the irrigation program will stop.

### Tank Level Lower than 30

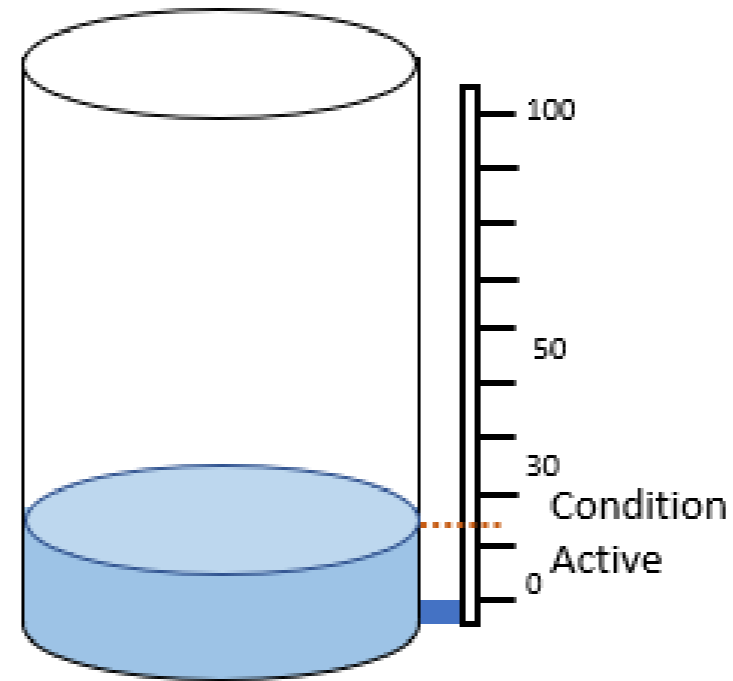

### Tank Level Higher than 30

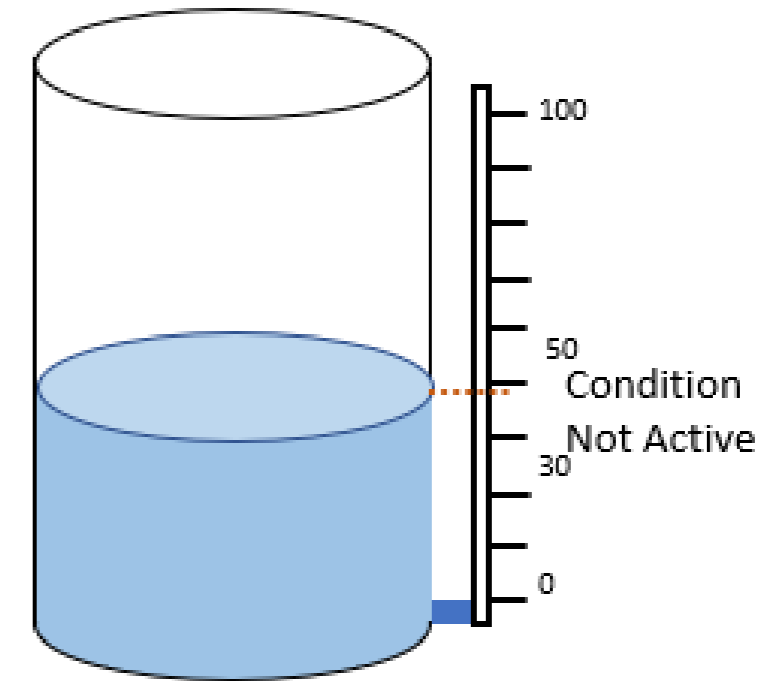

## Emergency Off Switch

It is a Digital input that can be selected to stop the running program or prevent a program from running when this switch is active. Select the DI for Emergency stop



**2.** The emergency switch has priority of the Trigger ON and Trigger Off.

**3.** When the emergency Off switch is active, it will be shown Red

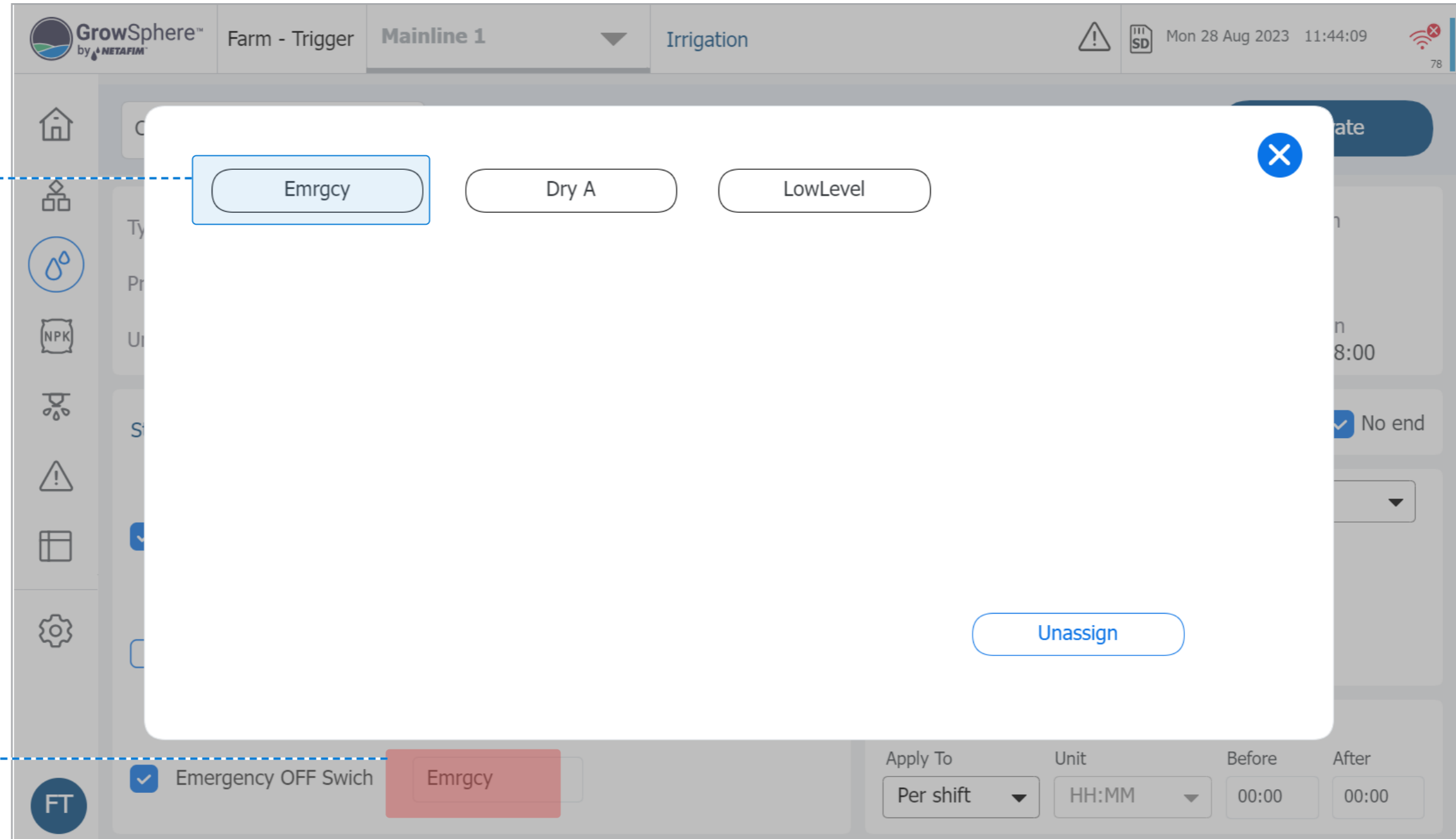

Farm - Trigger

Mainline 1
▼

Irrigation

⚠
SD
Mon 28 Aug 2023 11:48:46
82

Condition A

⚠
Uncompleted

Skip

Resume

Type Routine ▼

Priority Normal ▼

Unit MM:SS ▼

Amount (shift) 10:00

Factor 100%

Total 30:00 | 14.50 m³

Last irrigation  
28.08.23 | 11:47

Next irrigation  
29.08.23 | 08:00

Shifts (3)
Dosing
Prop
Settings

Start times Conditions ▼

Time period	Trigger	Actual
<input checked="" type="checkbox"/> 08:00 - 14:00	ON - ● Dry A OFF - ● No device	<span style="border: 1px solid #ccc; padding: 2px;">✎</span>
<input type="checkbox"/> 00:00 - 00:00	ON - ● No device OFF - ● No device	<span style="border: 1px solid #ccc; padding: 2px;">✎</span>

Date range 28.08.23 ▼  No end

Schedule Every (X) days ▼ 1 day ▼

1

Water before & after

Apply To	Unit	Before	After
<span style="border: 1px solid #ccc; padding: 2px;">Per shift</span> ▼	<span style="border: 1px solid #ccc; padding: 2px;">HH:MM</span> ▼	<span style="border: 1px solid #ccc; padding: 2px;">00:00</span>	<span style="border: 1px solid #ccc; padding: 2px;">00:00</span>

FT

Emergency OFF Switch

Emrgcy

●
Alert ON

3. When the emergency Off switch is active, it will be shown Red

252 | Conditions & Triggers

v2.5 | GrowSphere MAX User Manual

## Type One Shot Digital Input Dry Contact / Analog Input Sensor

- This irrigation program will only run a single cycle when the Trigger is ON. If the Dry Contact trigger or sensor trigger is ON, the program will be queued for execution, but it will only be activated if the Trigger remains ON for the specified On delay time.
- If the Trigger is still ON after the program has completed its cycle, the irrigation program will not start again until the Trigger changes from ON to OFF, and then back to ON again.
- All the program settings are the same for all types, including Only if On, One Shot, and Multi Shots. However, One Shot and Multi-Shot programs have an additional setting for Trigger Off.
- If the Trigger Off (dry contact or sensor) is selected, it will stop the running irrigation program immediately after the Off Delay.
- The Trigger Off has a higher priority than the Trigger ON. When both are active together, the program will not start.

### One Shot Trigger

Example of Condition One Shot

With storage tank and Two float (N.O. Switch)

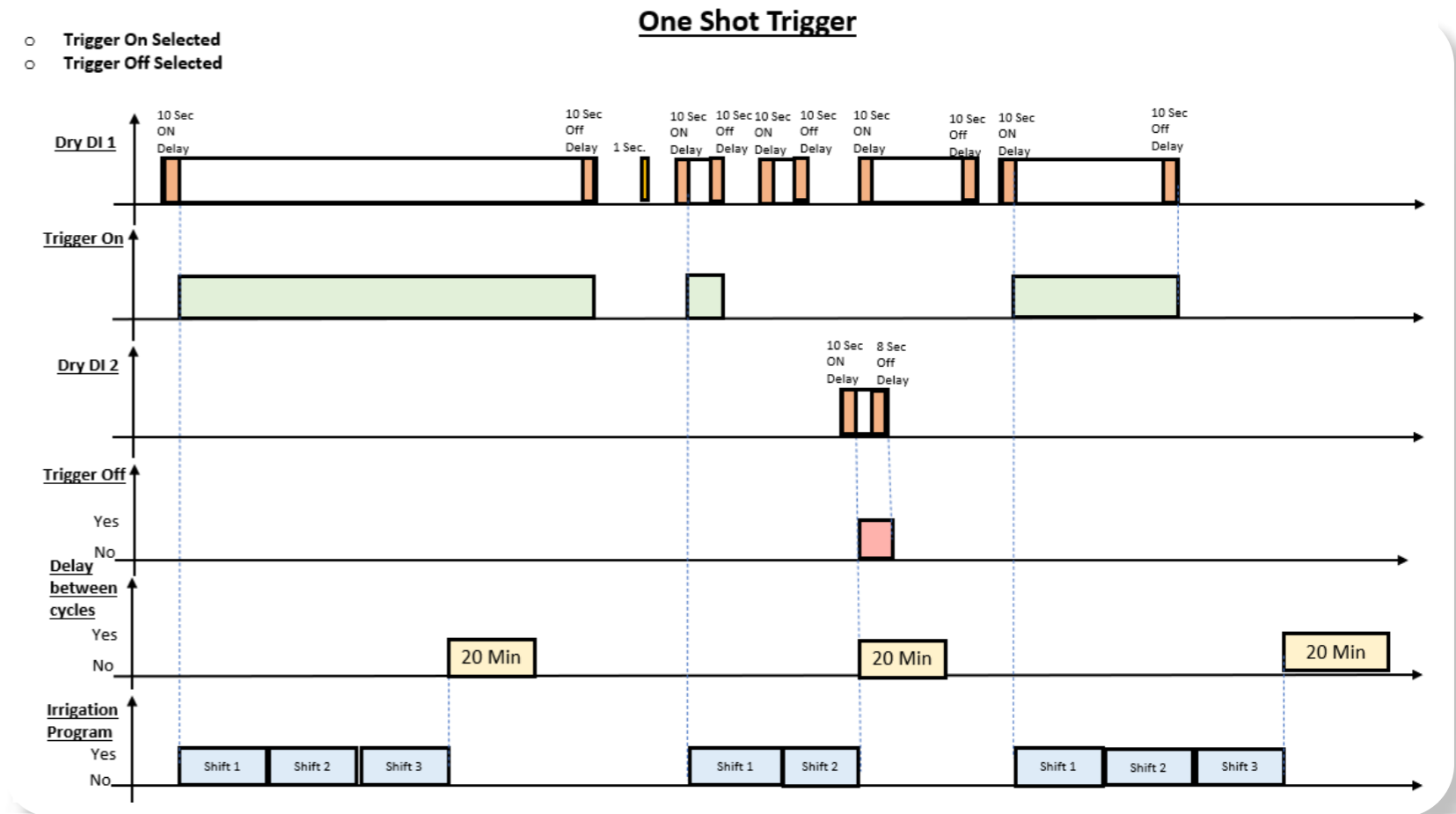
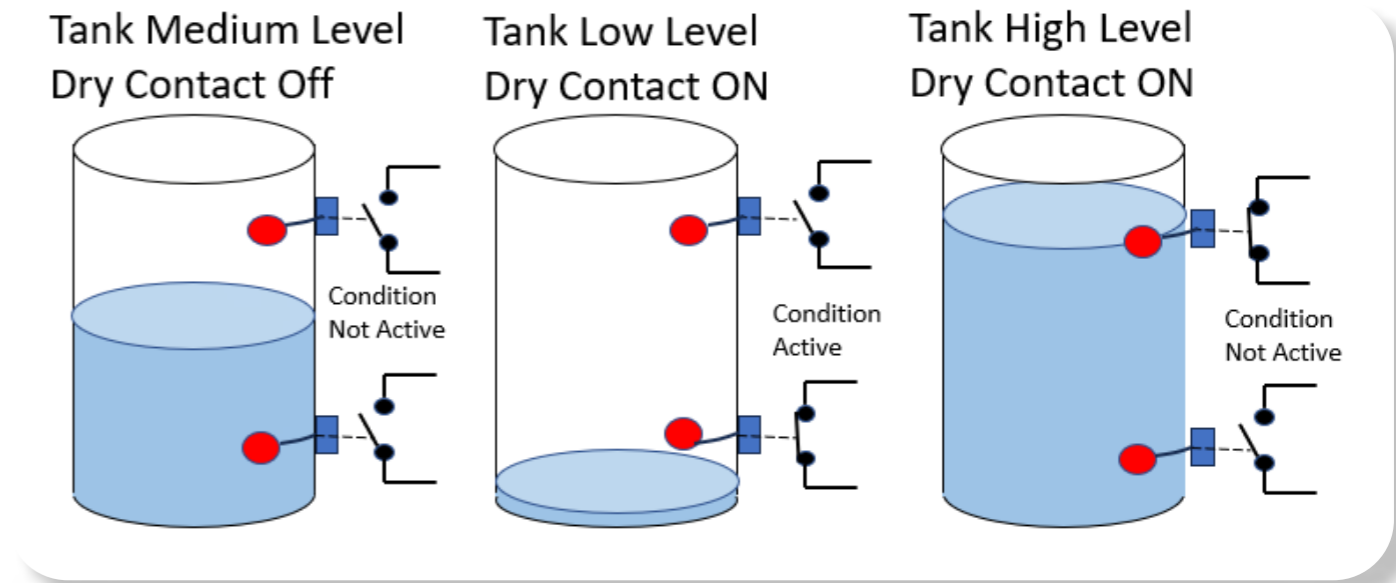

## Type - Multi Shots

- When using this function, the irrigation program will only run multiple cycles if the Trigger is ON.
- Once the Trigger is ON, the program will be posted in the Queue manager to be executed. The Trigger must remain ON for the On delay time that has been set by the user in the Settings section. If the Trigger stays ON when the program has finished running all the shifts, the irrigation program will start again.
- The program will only stop running when the Trigger changes from active to inactive, allowing the running program to complete all the shifts. The next time the Trigger is ON, the program will be triggered to start again.
- If the Trigger is turned Off, the program will end immediately after the set Off delay.

Example: when the temperature is lower than 2 C then the condition is Active

When the temperature is higher than 5 C then the condition is Not Active

Temperature Sensor  
Temp Lower than 2°C.  
Condition Active



Temperature Sensor  
Temp Lower than 5°C.  
Condition Not Active



The screenshot displays the 'GrowSphere™ by NETAFIM' interface for 'Farm - Trigger Mainline 1' under the 'Irrigation' section. The top bar shows the date 'Mon 28 Aug 2023' and time '11:48:46'. The main content area is for 'Condition A', which is marked as 'Uncompleted'. It features a 'Skip' button and a 'Resume' button. Below this, there are settings for 'Type' (Routine), 'Priority' (Normal), and 'Unit' (MM:SS). The 'Amount (shift)' is set to 10:00, 'Factor' is 100%, and 'Total' is 30:00 | 14.50 m³. The 'Last irrigation' was on 28.08.23 at 11:47, and the 'Next irrigation' is on 29.08.23 at 08:00. A 'Start times' table is shown with columns for 'Time period', 'Trigger', and 'Actual'. The first row is checked and shows '08:00 - 14:00' with 'ON - Dry A' and an edit icon. The second row is unchecked and shows '00:00 - 00:00' with 'ON - No device' and 'OFF - No device', also with an edit icon. There is an 'Emergency OFF Switch' section with 'Emrgcy' and a red 'Alert ON' indicator. On the right, there are 'Date range' (28.08.23) and 'Schedule' (Every (X) days, 1 day) settings. At the bottom right, there is a 'Water before & after' section with 'Apply To' (Per shift), 'Unit' (HH:MM), and 'Before' (00:00) and 'After' (00:00) times.

## 11. Mixing Valves + Pre-Ec

**1** / Mixing valves and  
Pre-EC - Diagram

**2** / Scada diagram with  
Pre-EC control

**3** / Mixing Valve Selection  
for Pre-EC Control



## 11.1 Mixing valves and Pre-EC - Diagram

- The Pre-EC control module controls the two sources of water quantities via a 3-way mixing valve to reach a target Pre-EC value.
- The mixing valve is a motorized 3-way valve with two Inlets, Source A and Source B, and one outlet C.
- The mixing valve will control the Pre EC (Electrical Conductivity) value of the mixing of the Fresh Water Source A with Drained/Maneuver Water Source B; the system has an EC sensor located at the C outlet of the mixing valve.
- The required EC Pre-Control Value can be set in the Dosing Program. The mixing valve will change the opening percentage of water sources A and B to obtain the required pre-EC value measured by the pre-EC sensor.
- Source A will always be with fresh water.
- Source B will always be with drained (maneuver) water. The water Source Low-Level Switch is a digital input from a low-level/low-flout switch. This device will send a signal when there is low-level water from each water source. When the signal is active, it will pause the irrigation process and raise a fault alert.
- The level sensor is an analog sensor that measures the tank level of each water source tank. At the Alerts settings, there will be an option to select the tank level for alerts and alert type.

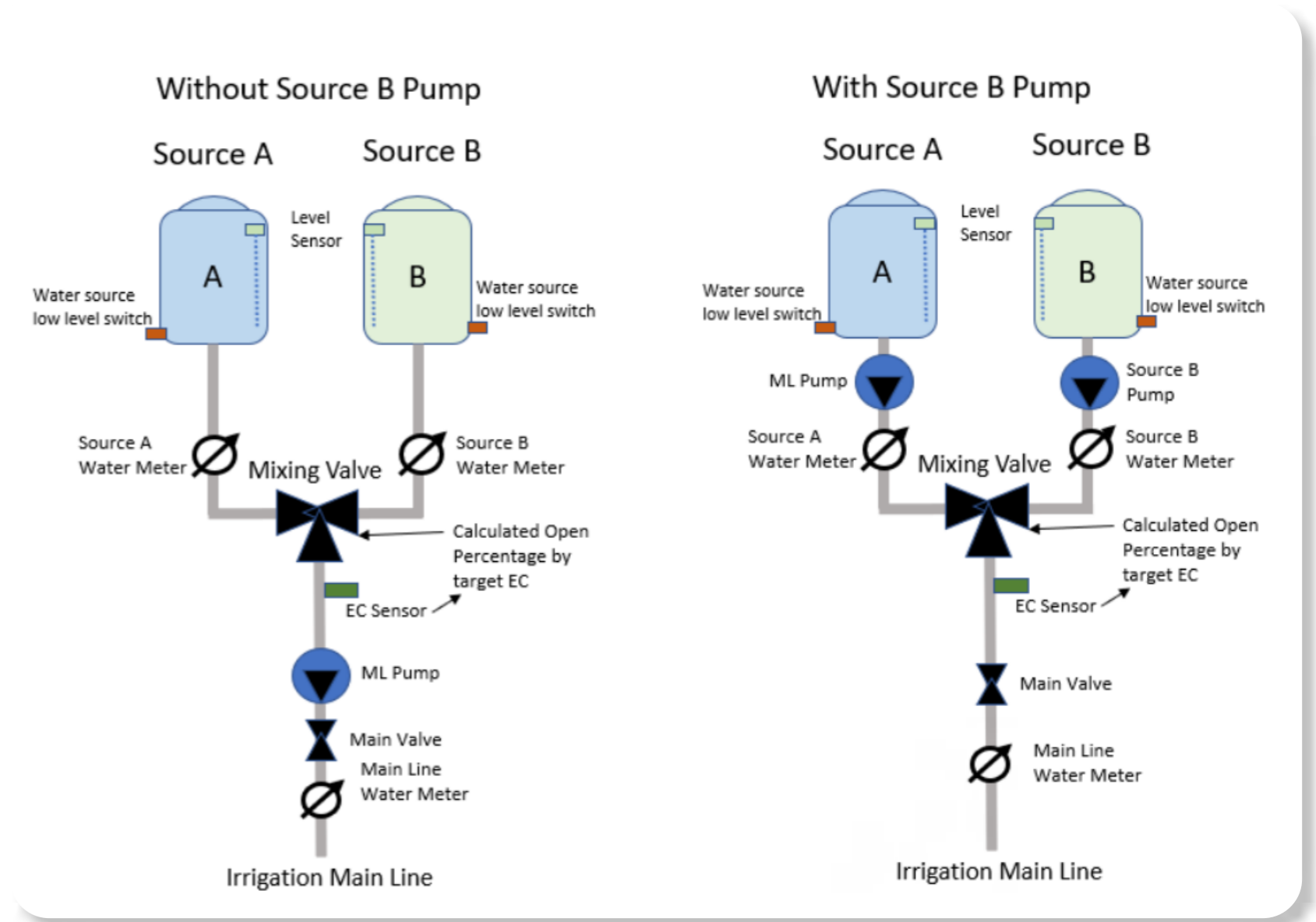

## 11.2 Scada diagram with Pre-EC control

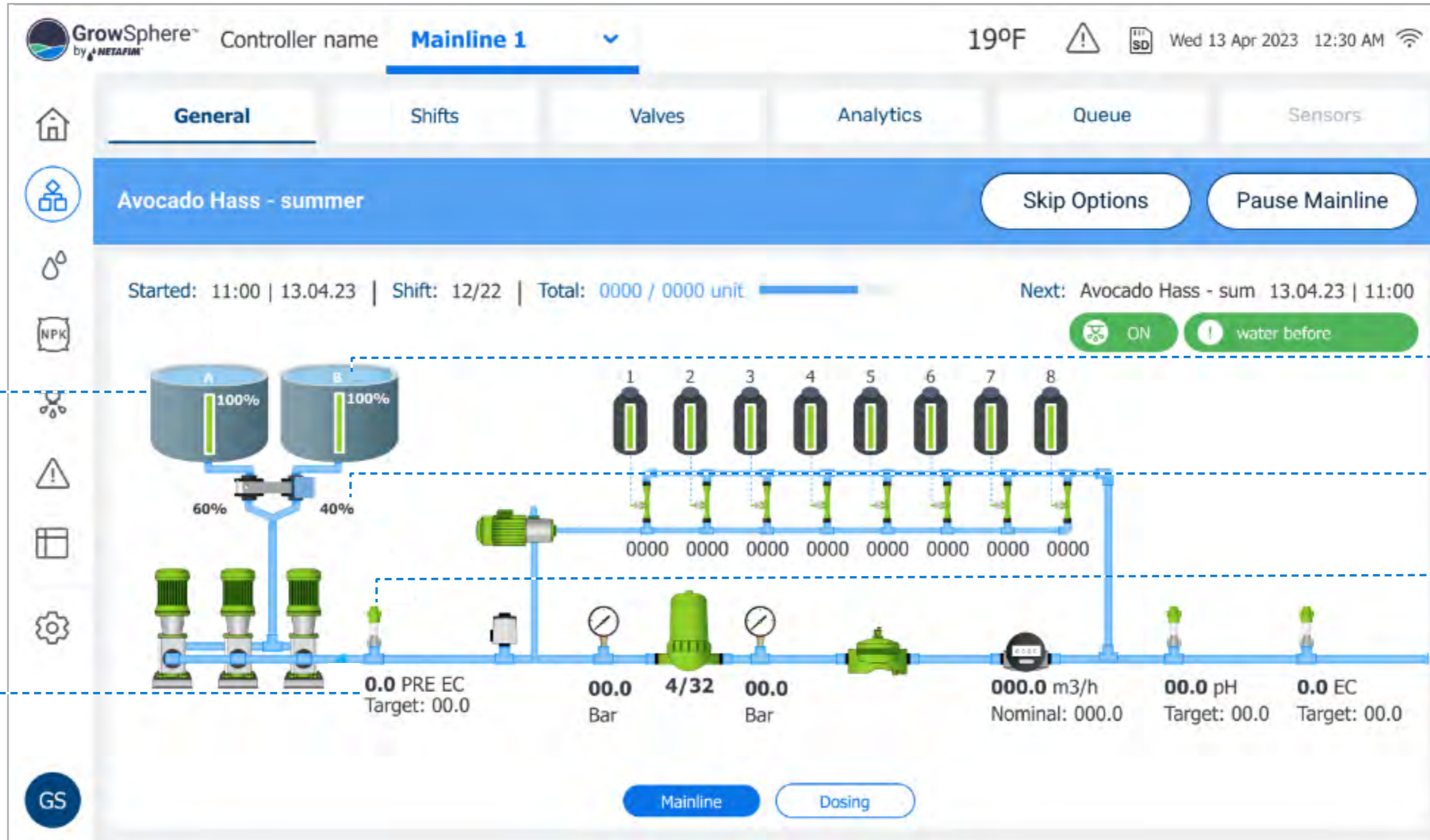

Source A Fresh Water  
and tank level

Source B Recycle  
Water and tank level

Source B actual  
percentage

Pre EC sensor

Pre EC actual value  
and target



## 11.3 Mixing Valve Selection for Pre-EC Control

**GrowSphere™** by NETAFIM

CS TEST Mainline 1 Settings

Sun 03 Aug 2025 16:06:04

Mainline Configuration Control Configuration Local I/O Remote I/O Communication Wiring Diagram

Mainline Sub-Mainlines Pump Station Filter Station **Dosing Station** Cool & Mist Valves Other Devices

**Dosing Station**

Extensive  Intensive

Dosing Channels   Mixing valve / PRE EC control

CH	1	2	3	4	5	6	7	8
Dosing meter	<input checked="" type="checkbox"/>	<input checked="" type="checkbox"/>	<input checked="" type="checkbox"/>	<input checked="" type="checkbox"/>				
Agitator	<input checked="" type="checkbox"/>	<input checked="" type="checkbox"/>	<input checked="" type="checkbox"/>	<input checked="" type="checkbox"/>				
Fert tank level	<input type="checkbox"/>	<input type="checkbox"/>	<input type="checkbox"/>	<input type="checkbox"/>				

Dosing Booster  Booster Pump O.L.

Dosing Pressure switch  Agitator pump

EC sensors  pH sensors

In the Dosing Station configuration screen

Sign the Mixing valve indication



## Pre-EC control Mixing Valve – outputs settings

Under Local I/O tab, click on Assign to select the outputs that are related to the EC Pre control

Once clicking Assign, a list of related outputs will be presented

Ensure that the devices below are selected:

Module	DO	Device type	NO.	Source	Name	Flow	Area	Assigned
DO573.1	8	Dosing Channel	3	D.Statio1	DCH1.3	50.00 L/h	—	Unassign
DO573.1	9	Dosing Channel	4	D.Statio1				
DO573.1	10	Pump	1	M.Line				
DO573.1	11	MainValve	1	M.Line				
DO573.1	12	Sub Main valve	1	M.Line				
DO573.1	13	Sub Main valve	2	M.Line				
DO573.1	14	Assign	0					

Valve (0)	Dosing Booster (0)	Condition active (0)
MainValve (0)	Normal Alarm (4)	EC Pre-Control open (1)
Pump (0)	Selector (0)	EC Pre-Control close (1)
Filter (1)	Agitator (5)	Relay (0)
Main Filter Valve (0)	Cooling (1)	Same as DO
Dosing Channel (1)	Misting (0)	EC Pre-Control pump (1)
Mist Main valve / pump (1)	Cool Main valve / pump (1)	Agitator Pump (0)
Sub Main valve (0)	Critical Alarm (4)	Well Pump (1)

2. EC Pre-control open

3. EC Pre-control close

1. Pre-EC pump



## Pre-EC control Mixing Valve – Digital Inputs settings

Under Local I/O tab, click on Assign to select the inputs that are related to the EC Pre-control

Ensure you assign the below devices, if are connected:

- Source Low Level (sensor 1)
- Source Low Level (sensor 2)
- Source WM 1(sensor 1)
- Source WM 1(sensor 2)
- Dosing pressure switch

The screenshot shows the GrowSphere MAX interface with the following details:

- Header:** GrowSphere™ by NETAFIM, CS TEST, All Mainlines, Settings, Mon 04 Aug 2025 17:10:01, 100% battery.
- Navigation:** Mainline Configuration, Control Configuration, **Local I/O**, Remote I/O, Communication, Wiring Diagram.
- Sub-navigation:** Local digital output, **Local digital input**, Local analog input.
- Table:**

Module	DI	Device type	NO.	Source	Name	Type	Rate	Assigned
PM5052	0	Water Meter	1	M.Line1	WMTR1.1	LPP	10.00	Unassign
PM5052	1	Dosing Meter	1	D.Statio1	DM...			
PM5052	2	Dosing Meter	2	D.Statio1	DM...			
PM5052	3	Dosing Meter	3	D.Statio1	DM...			
PM5052	4	Dosing Meter	4	D.Statio1	DM...			
PM5052	5	Fertilizer Tank Low	1	M.Line2	FF...			
PM5052	6	Assign	0					
- Modal Window:** "Select input type and device" with "Control" selected. The "pH" device is highlighted. Other visible devices include EC, Temperature, Humidity, Radiation, etc.



## Pre-EC control Mixing Valve – Analogs Inputs settings

1. Under Local I/O tab, Assign the analog sensors that are related to the EC Pre-control

The screenshot shows the 'Local I/O' configuration page in the GrowSphere MAX interface. The 'Local analog input' section is active, showing two input channels. The first channel, AI561.1 2, is assigned to 'Fertilizer Tank level' with an input range of 4-20 mA and an output range of 0-100. The second channel, AI561.1 3, has an 'Assign' button next to it. A modal window titled 'Select input type and device' is open, displaying a grid of sensor options. The 'EC Pre-Control' sensor is highlighted in the modal. The interface also shows a navigation bar with 'Mainline Configuration', 'Control Configuration', and 'Local I/O' tabs, and a sidebar with various system icons.

2. Set the output and input range, name of the sensor and offset



## Pre-EC control Mixing Valve – Analogs Inputs settings

The screenshot displays the 'Local I/O' configuration page in the GrowSphere MAX interface. The page is titled 'CS TEST' and 'All Mainlines'. It features a navigation menu with options like 'Mainline Configuration', 'Control Configuration', 'Local I/O', 'Remote I/O', 'Communication', and 'Wiring Diagram'. Under 'Local I/O', there are sub-sections for 'Local digital output', 'Local digital input', and 'Local analog input'. The 'Local analog input' section contains a table with columns: Module, AI, Device type, NO., Source, Name, Input, Unit, and Assigned. The first row shows AI561.1 2 assigned to 'Fertilizer Tank level' (NO. 1, Source M.Line2, Name FRTL2.1, Input 4 - 20 mA). Below the table are input range and output range settings for each AI. A modal window titled 'Select input type and device' is open, showing a grid of sensor options. A blue arrow points from the 'Assign' button in the table to the 'DP Filter Sensor' option in the modal window. At the bottom of the page, there is a pagination control showing 'page 2 of page 2'.

Module	AI	Device type	NO.	Source	Name	Input	Unit	Assigned
AI561.1	2	Fertilizer Tank level	1	M.Line2	FRTL2.1	4 - 20 mA		

By skip between the pages, the source Level sensors can Assigned as well



## Pre-EC control Mixing Valve – Settings

**1. Mixing Valve Travel control Time:** it is the time that takes the mixing valve to change from Home Position to full open; travel time from source A full open to source B full open. This value is described on the mixing valve data sheet. Other option is to measure with a stoper the travel time.

**2. Return to Home Position:** When this option is selected, at the end of the process the mixing valve will return to Home Position, Source A (fresh water) fully open to outlet C.

**3. EC Pre Control activation.**

**4. Pre EC-Control cycle,** it is a travel time from the valve last position change time to the EC Sensor reaction. The units are Second, the default value is 8 Sec.

**5. Dead Band, it is the delta value,** set by the user, from the Pre EC target. When the actual value reaches these limits, the valve will stay at this position. No corrections will be made. The default value is 0.1mS/cm.

**6. EC Pre- Fine Tuning Control Range,** it is a control range for fine-tuning adjusting. The value is a delta value from the target Pre EC value. The default is 0.4, it is a fixed value.

**7. Pre-EC Control Course Tuning:** It is a time calculated Step for the length of the time that the valve will be activated for a correction of the course tuning. This value is the percentage of the total Valve control time.

**8. Pre-EC Control Fine Tuning:** It is a time calculated Step for the length of the time that the valve will be activated for a correction of the fine tuning. This value is the percentage of the total Valve control time.

Setting ID	Setting Name	Value	Unit
1	Mixing valve travel control time	90	sec
2	Return to home position	<input checked="" type="checkbox"/>	
3	Pre EC control	<input checked="" type="checkbox"/>	
4	EC Pre- Control Cycle	8	sec
5	Control dead Band	0.10	mS/cm
6	EC Pre- Fine Tuning Control Range	0.40	mS/cm
7	Pre-EC Control Course Tuning - Step	3.00 %	
8	Pre-EC Control Fine Tuning - Step	2.00 %	



## Pre-EC control Mixing Valve – Dosing Recipe

The screenshot displays the GrowSphere MAX user interface. At the top, the header includes the GrowSphere logo, the farm name 'Farm', the mainline 'Mainline 1', and the active menu 'Dosing'. The date and time are shown as 'Wed 04 Oct 2023 10:32:37'. Below the header, there are navigation tabs: 'Recipes' (selected), 'Overview User', 'Overview Technician', 'General Settings', and 'Channels Settings'. The main content area shows a list of recipes. The first recipe is '1 Pre EC', which is checked. Below it are several 'Insert new recipe' buttons, each accompanied by a plus sign and a small icon representing a different fertilizer or nutrient (NPK, a warning sign, a calendar, a gear, and FM).



## Pre-EC control Mixing Valve – Dosing Recipe

GrowSphere™ by NETAFIM CS TEST Mainline 2 Dosing Simulation Tue 06 Jan 2026 13:58:00

Recipe Name Undefined Targets EC 1.0 pH 7.5 Pre EC 0.0

Active	ID	Dosing channel	Method	Quantity / Time	Value	DM Control
<input checked="" type="checkbox"/>	1	DCH2.1	1/1000	Quantity	5 L	-
<input checked="" type="checkbox"/>	2	DCH2.2	1/1000	Quantity	5 L	-
<input checked="" type="checkbox"/>	3	DCH2.3	1/1000	Quantity	2 L	-
<input type="checkbox"/>	4					



## 12. Remote Units

**1** / Weather station

**2** / RadioNet to  
GrowSphere™ MAX

**3** / SingleNet to  
GrowSphere™ MAX



## 12.1 Weather Station

The controller Supports RadioNet, SingleNet, NetRTU & Davis WS.

- SingleNet and RadioNet - RS485
- Davis Weather Station - RS232
- NetRTU - RS232, 2nd module/ The module for the NetRTU should be ordered and connected separately.

**Connect to Davis Weather station.**

**The data has been collected and will be presented on the GrowSphere(TM) Cloud.**

/RS232 Module

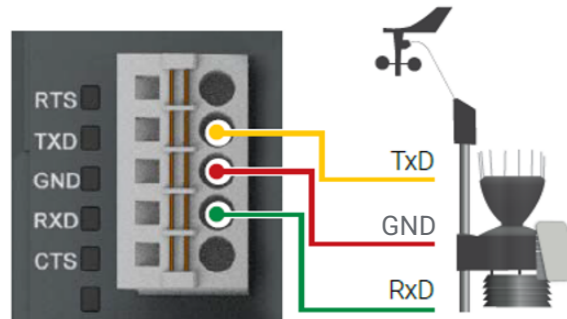

Signal	Description
RTS	Request To Send DCE is ready to accept data from the DTE
TxD	Transmit Data (output)
GND	Common Ground
RxD	Receive Data (input)
CTS	Clear To Send (input) DCE is ready to accept data from the DTE

State LEDs

Signal	Color	State	Description
TxD	Yellow	ON (blinking)	Transmitting
RxD	Yellow	ON (blinking)	Receiving

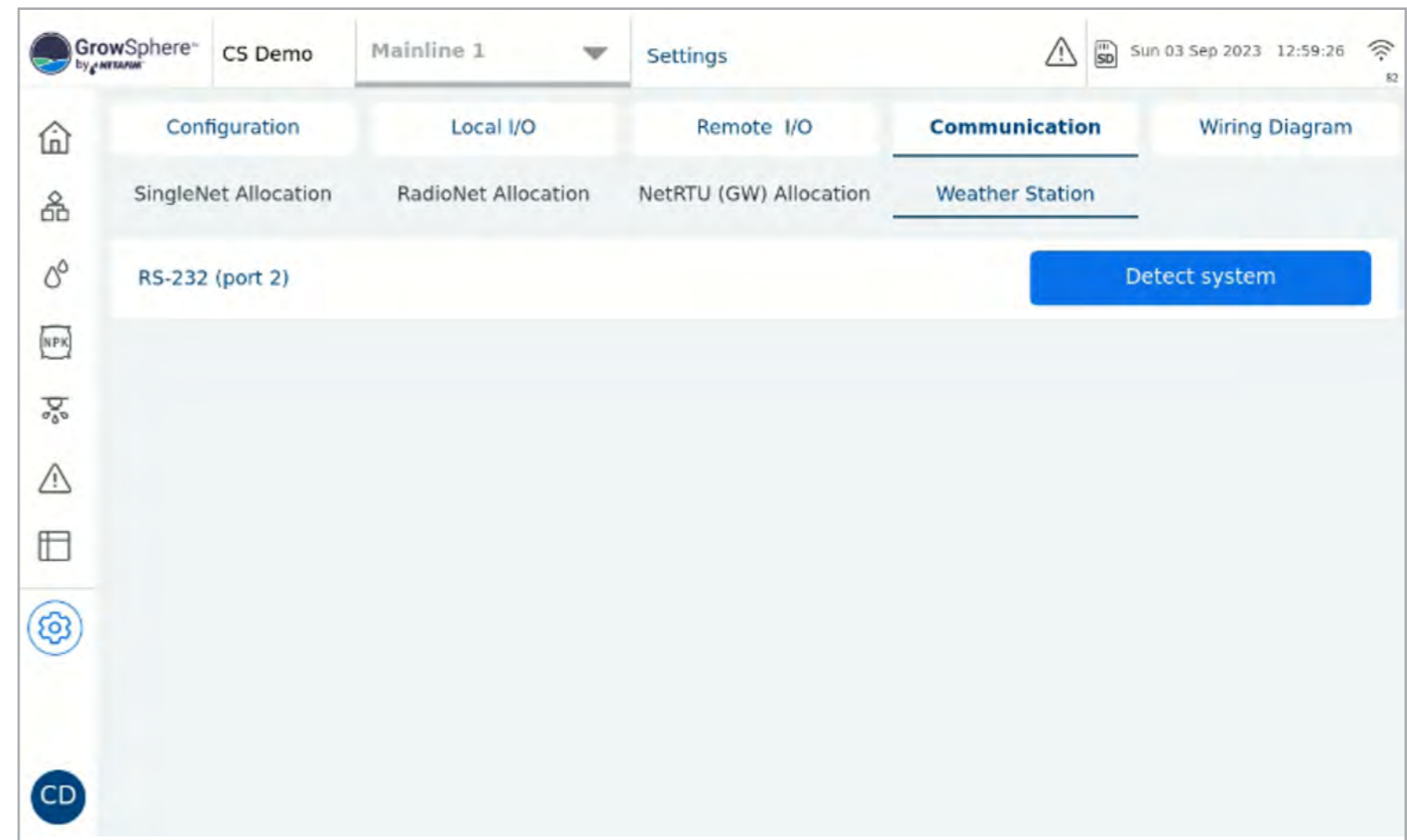

## 12.2 RadioNet to GrowSphere™ MAX

RadioNet interface with GS is currently only via RS485. RS485 Module must be installed on Upper Port. Note the “DIP Switch” position on the RS 485 module marked in RED Must be towards the “ON” Side

### I Wiring Between Host & GS max Controller

A to A & B To B. LK1 & LK2 Jumper on the RadioNet Host should be on Upper side

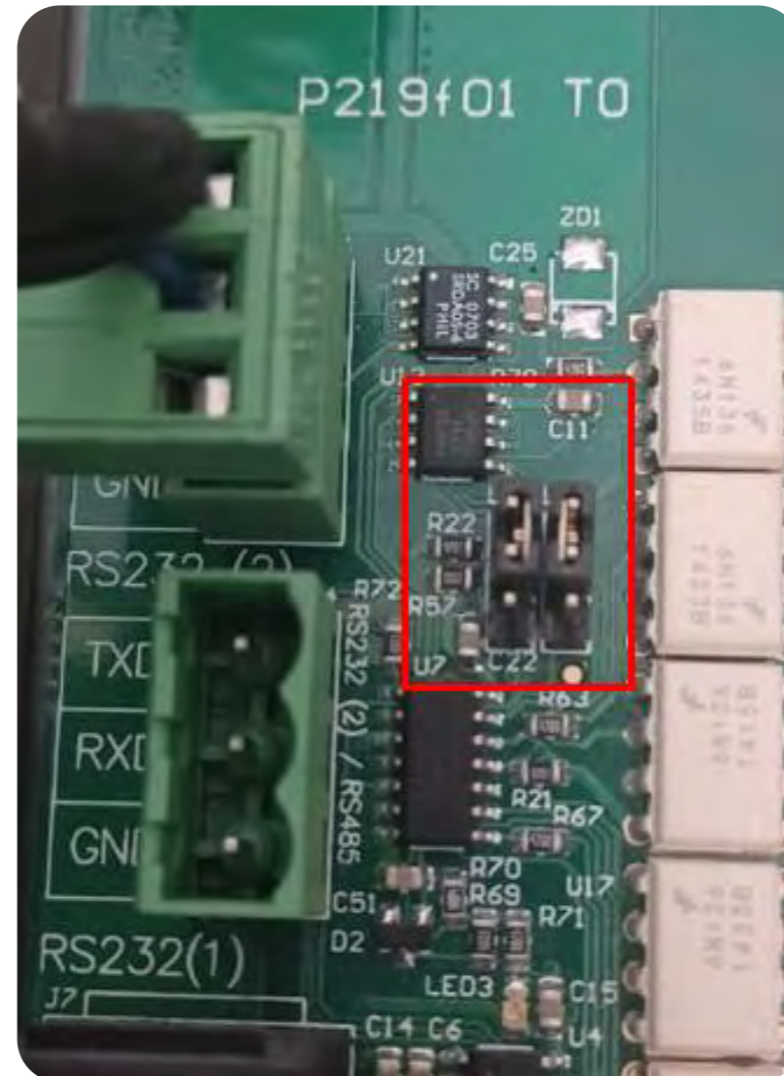
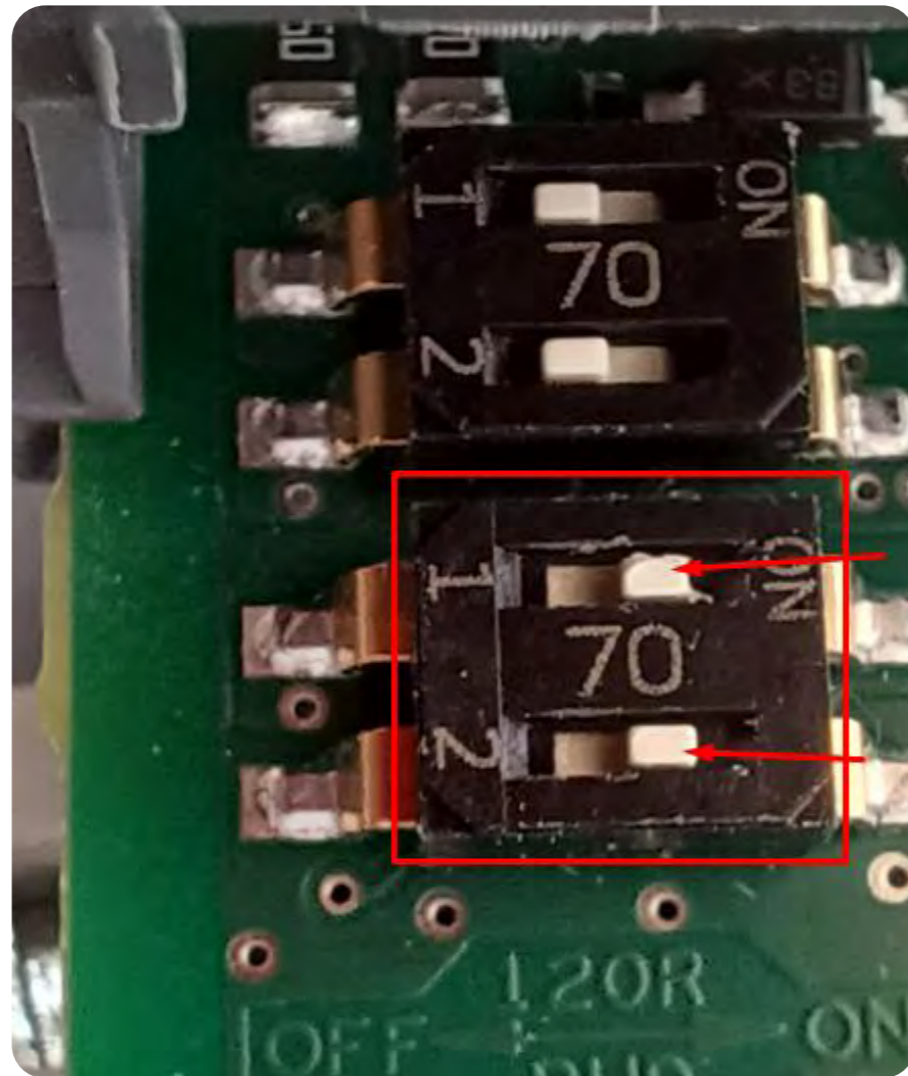
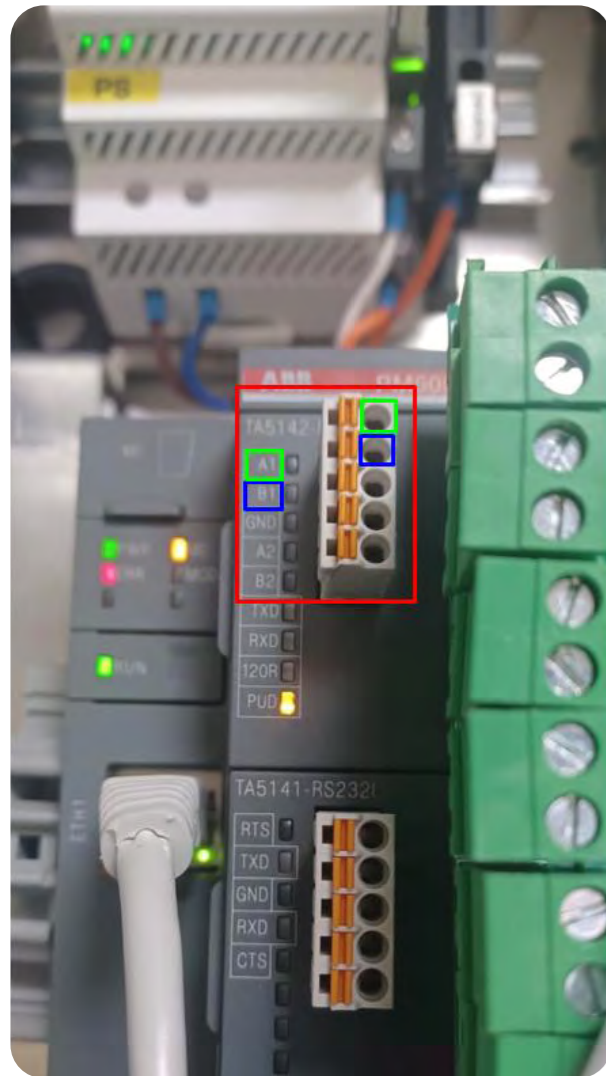

RadioNet host

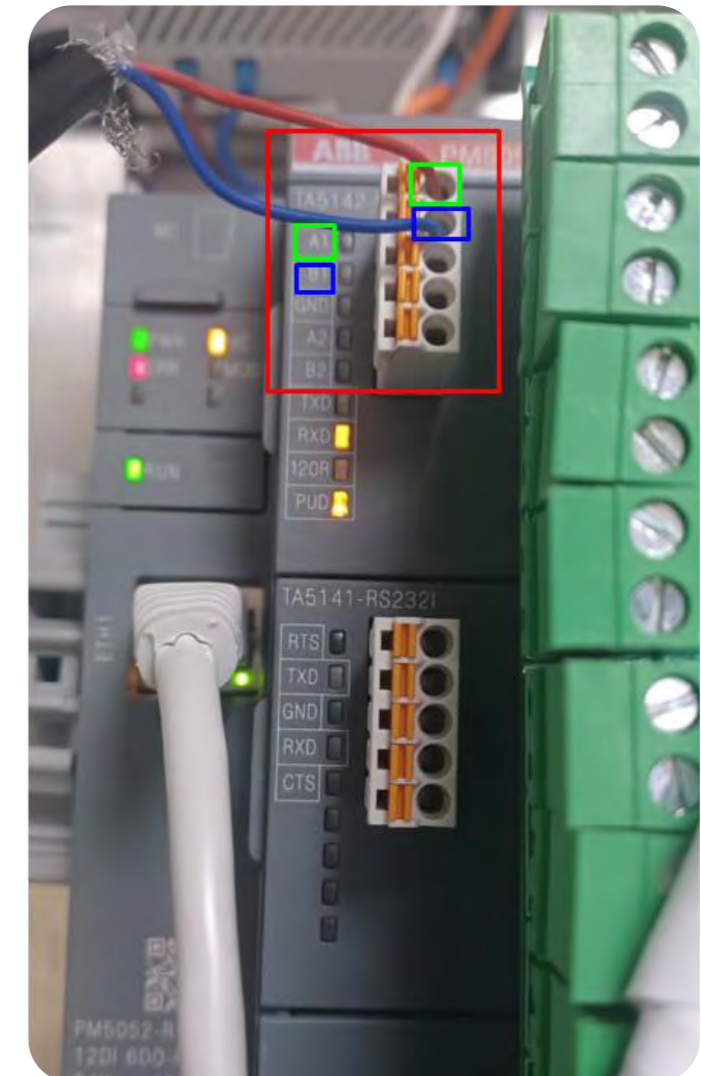

GrowSphere™ Max



Required Polenet Version - Always Check for Latest & Recommended Versions of PoleNet & Polenet2Max App. Use PoleNet Version: 3.26.42 Or latest Version.

- Use Host Firmware Version: 3.29.24 Or the latest Version
- Use Base Firmware Version: 2.74 Or the latest Version

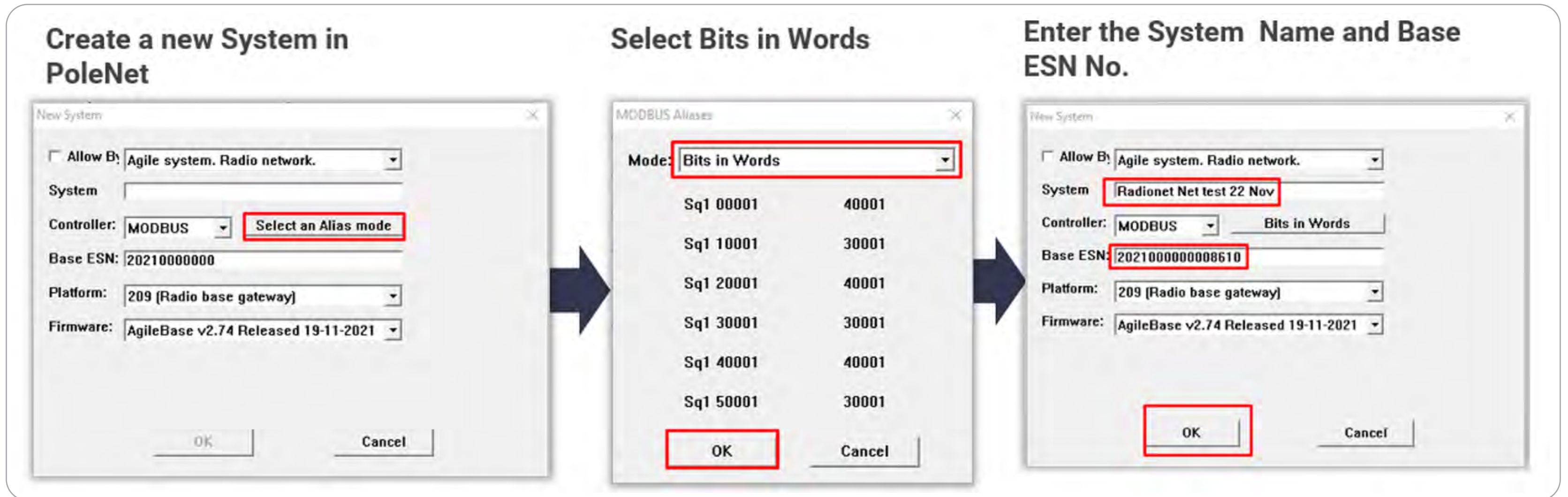

If you want to connect the existing “RadioNet from NetBeat to GS Max,” then you need to make some Changes in Polenet:

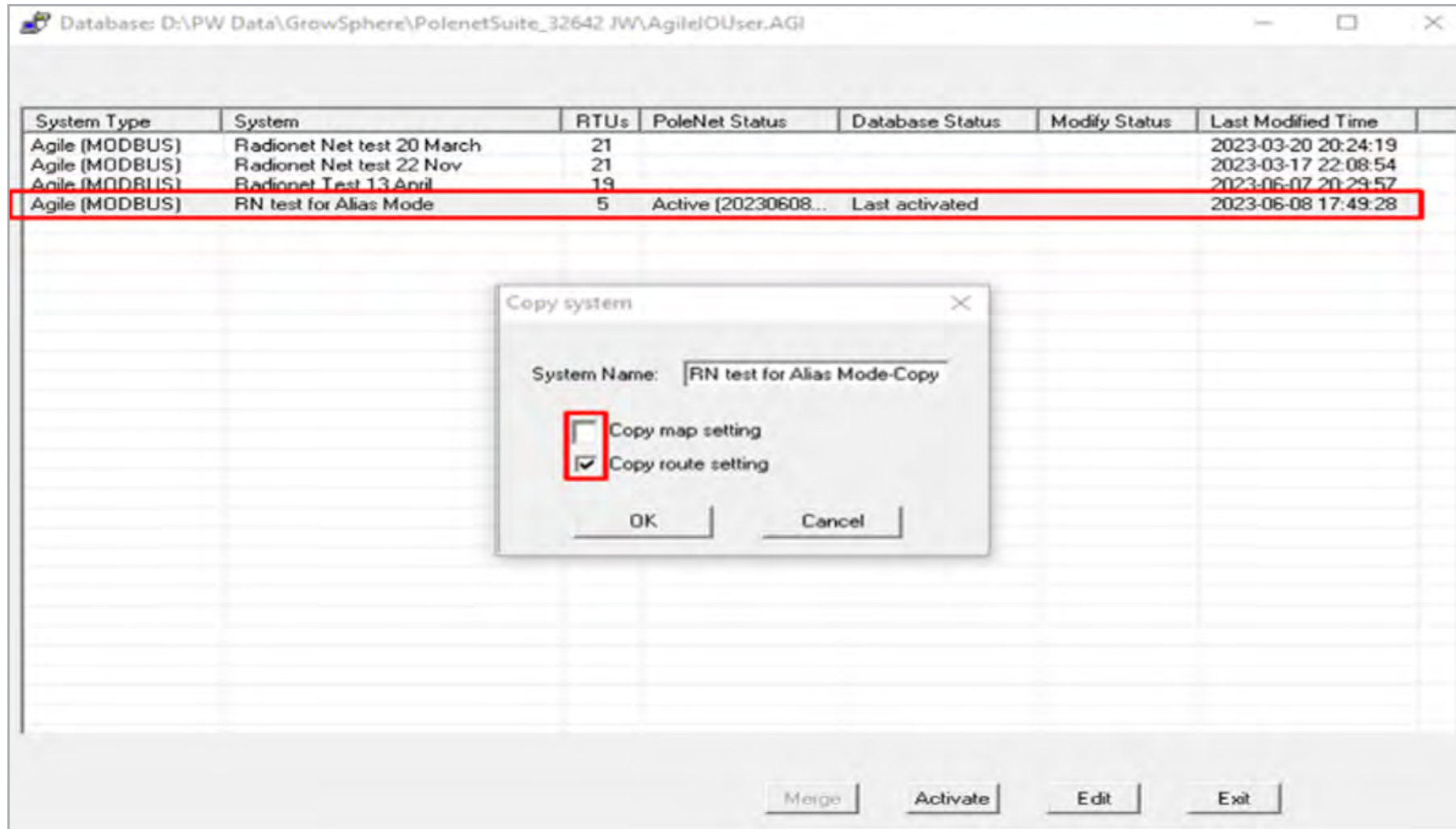

Right-click on Activated File and Copy Radionet System. Uncheck Map & Route Setting & Click “ OK”

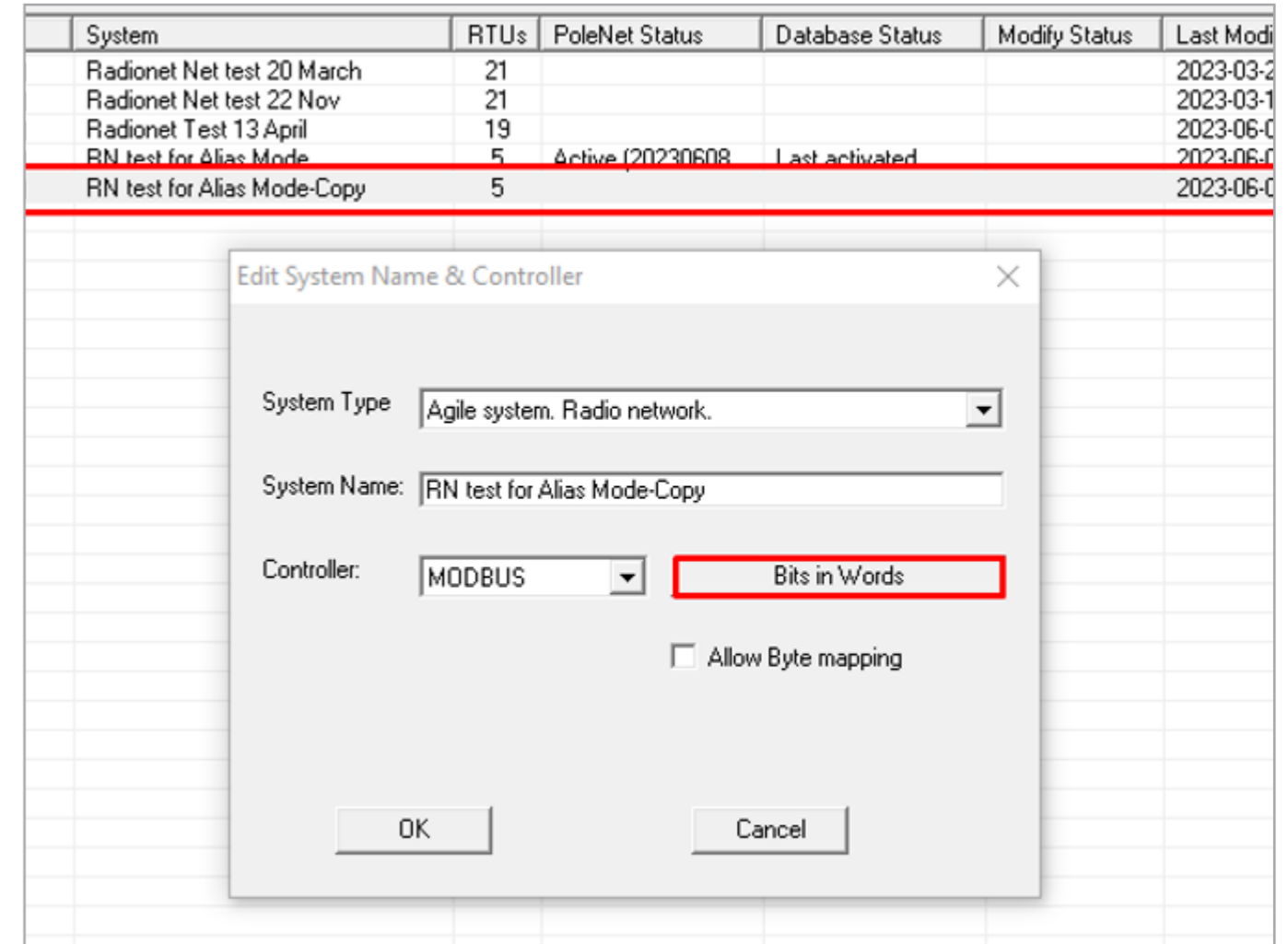

Right Click on Copied System and Select “ Edit System name & Controller” and Change Alias Mode to “Bits in Words”



Earlier System Alias Mode was “Bytes in Words.” for GS Max, we Need to Change to “Bits in Words”.

The image shows two side-by-side screenshots of a software application window titled "Database: D:\PW Data\GrowSphere\PolenetSuite\_32642 JW\AgileIOUser.AGI".

**Left Screenshot:** A table lists system data. A dialog box titled "Edit System Name & Controller" is open. The "Controller" dropdown is set to "MODBUS" and the "Mode" dropdown is set to "Bytes in Words". A red box highlights the "Bytes in Words" option.

System Type	System	RTUs	PoleNet Status	Database Status	Modify Status	Last Modified Time
Agile (MODBUS)	Radionet Net test 20 March	21				2023-03-20 20:24:19
Agile (MODBUS)	Radionet Net test 22 Nov	21				2023-03-17 22:08:54
Agile (MODBUS)	Radionet Test 13 April	19				2023-06-07 20:29:57
Agile (MODBUS)	RN test for Alias Mode	5	Active (20230608)	Last activated		2023-06-08 11:58:57

**Right Screenshot:** The same table is shown. A dialog box titled "MODBUS Aliases" is open. The "Mode" dropdown is now set to "Bits in Words". A red box highlights the "Bits in Words" option. An orange arrow points from the "Bytes in Words" option in the left screenshot to the "Bits in Words" option in this screenshot.

System Type	System	RTUs	PoleNet Status	Database Status	Modify Status	Last Modified Time
Agile (MODBUS)	Radionet Net test 20 March	21				2023-03-20 20:24:19
Agile (MODBUS)	Radionet Net test 22 Nov	21				2023-03-17 22:08:54
Agile (MODBUS)	Radionet Test 13 April	19				2023-06-07 20:29:57
Agile (MODBUS)	RN test for Alias Mode	5	Active (20230608)	Last activated		2023-06-08 11:58:57

At the bottom of both screenshots are buttons for "Merge", "Activate", "Edit", and "Exit".



If your Radionet System Connected with NMC, then you need to Change Controller Type to “ModBus” & Alias Mode “Bits in Words” for GS Max .

The screenshot displays two instances of the 'Edit System Name & Controller' dialog box. The left instance shows the 'Controller' dropdown menu set to 'NMC PRO'. The right instance shows the 'Controller' dropdown menu set to 'MODBUS' and the 'Bits in Words' checkbox checked. A large blue arrow points from the left instance to the right instance, indicating the change. An orange arrow points from the 'NMC PRO' dropdown in the left instance to the 'MODBUS' dropdown in the right instance.

System Type	System	RTUs	PoleNet Status	Database Status	Modify Status	Last Modified Time
Agle (MODBUS)	Radionet Net test 20 March	21				2023-03-20 20:24:19
Agle (MODBUS)	Radionet Net test 22 Nov	21				2023-03-17 22:08:54
Agle (MODBUS)	Radionet Test 13 April	19				2023-06-07 20:29:57
Agle (MODBUS)	RN test for Alias Mode	5	Active (20230608...	Last activated		2023-06-08 17:49:28
Agle (MODBUS)	RN test for Alias Mode-Copy	5				2023-06-08 17:49:28



Make sure that all RTUs with expansion cards are added & Activate the System.

Database: D:\PW Data\GrowSphere\PolenetSuite\_32642 JW\AgileIOUser.AGI

System Type	System	RTUs	PoleNet Status	Database Status	Modify Status	Last Modified Time
Agile (MODBUS)	Radionet 12Jan22	10				2023-01-12 19:42:31
Agile (MODBUS)	Radionet Net test 22 Nov	21	Active (20230103...	Last activated		2023-01-03 22:29:22

Merge   Activate   Edit   Exit





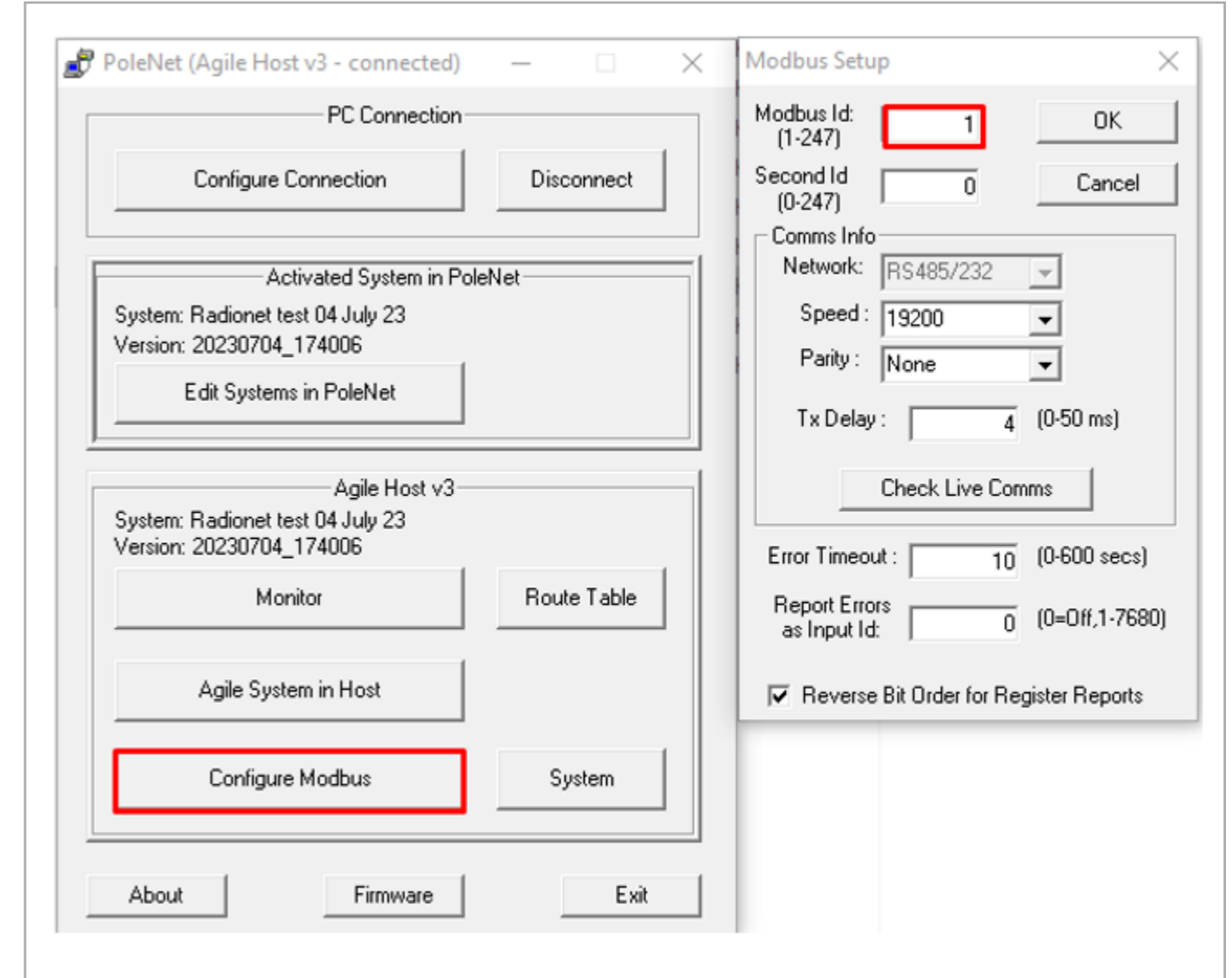
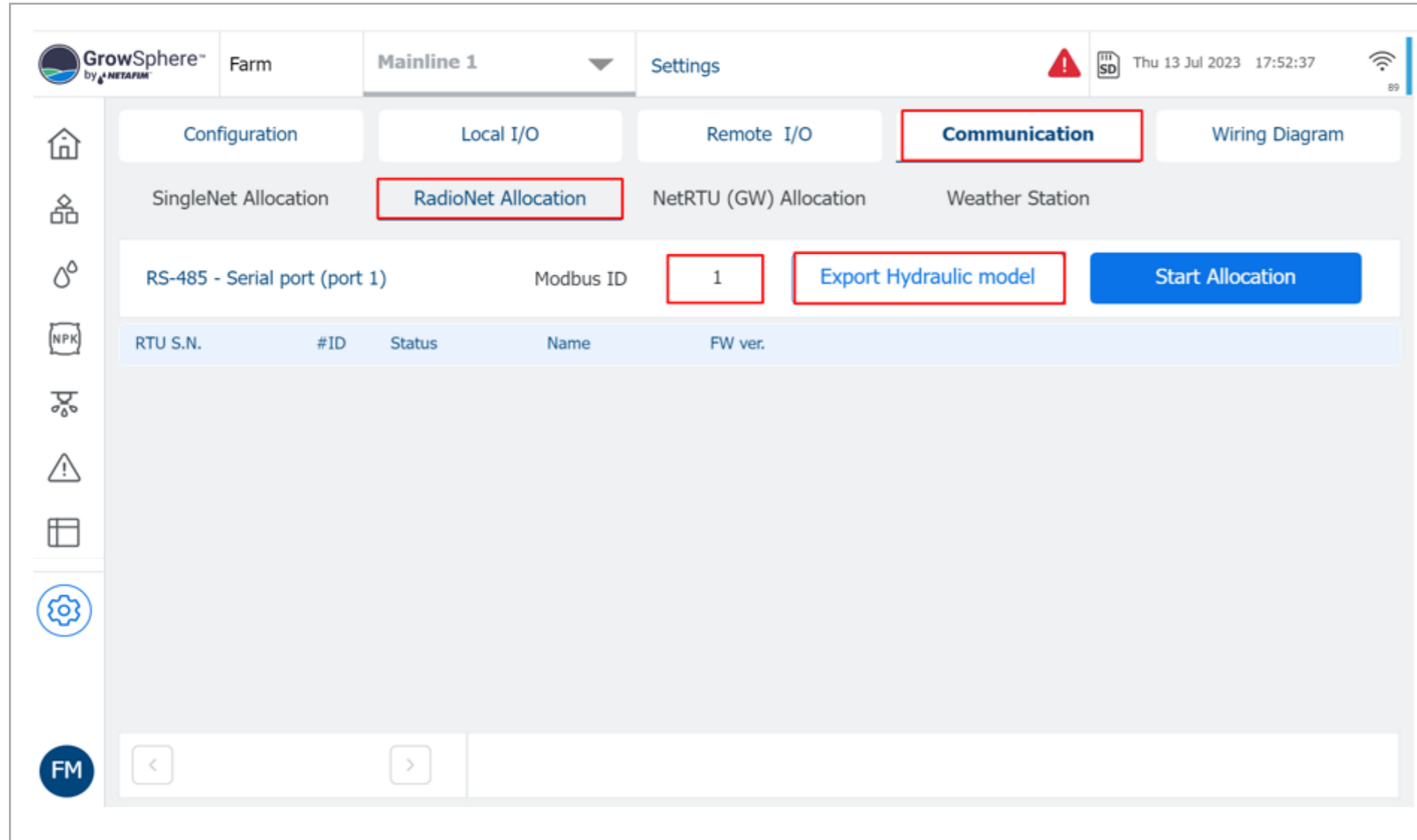



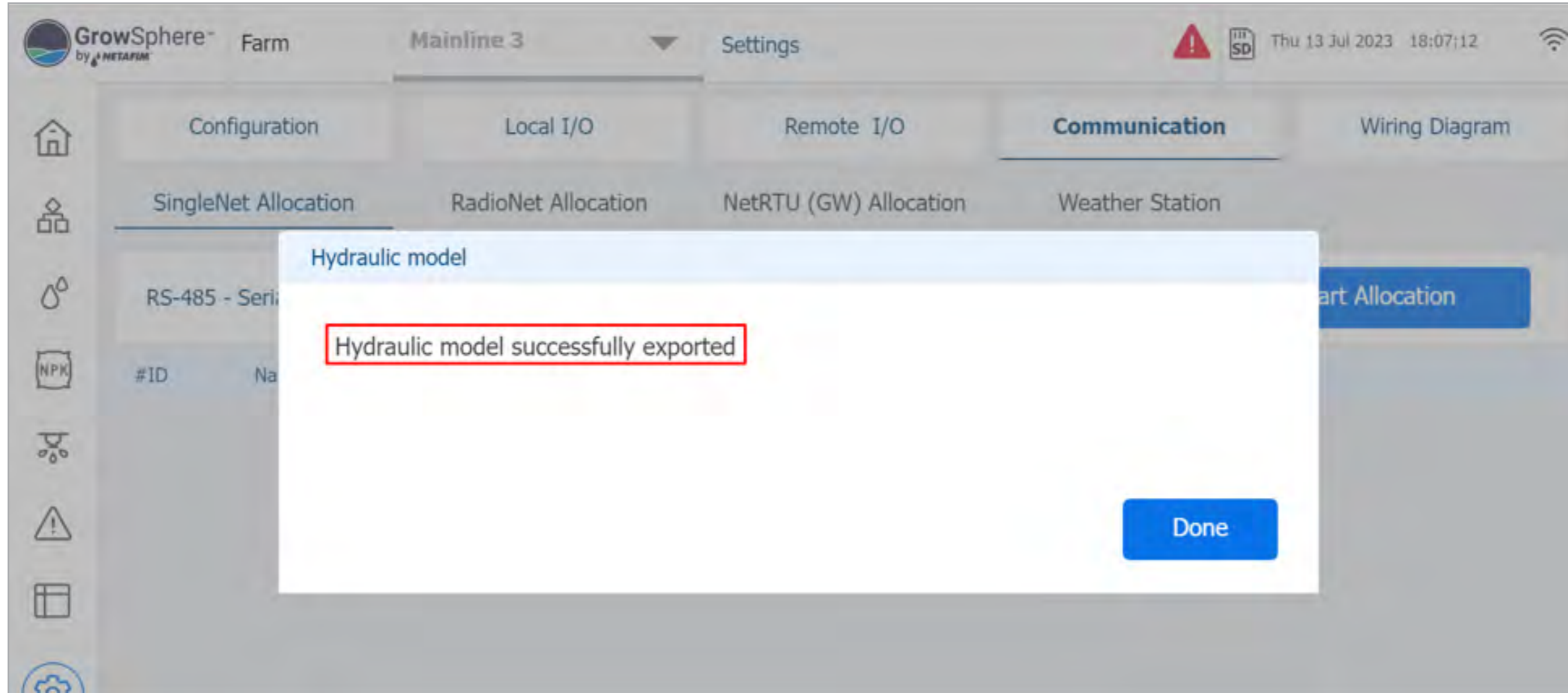





Navigate to Settings >> Communication >> Select RadioNet >>Export Hydraulic Model. Also Check Modbus ID is same on Modbus Setup & Allocation Screen.



## After Successful “Export”, Click on Done



## Open “Polenet2Max” Application

Name	Date modified	Type	Size
 configuration.properties	11/15/2022 1:13 PM	PROPERTIES File	1 KB
 D3DCompiler_47_cor3.dll	5/6/2022 8:46 PM	Application extens...	4,031 KB
 devices_types	11/10/2022 7:00 PM	JSON File	23 KB
 illust58-1841	11/28/2022 5:35 PM	JPG File	1,468 KB
 Penlmc_cor3.dll	11/19/2022 11:16 PM	Application extens...	143 KB
 Polenet2Max	1/18/2023 2:32 PM	Application	155,001 KB
 Polenet2Max.pdb	1/18/2023 2:31 PM	PDB File	50 KB
 PresentationNative_cor3.dll	10/13/2022 11:46 PM	Application extens...	924 KB
 sni.dll	7/12/2017 4:54 PM	Application extens...	134 KB
 SQLite.Interop.dll	11/2/2021 11:17 PM	Application extens...	1,343 KB
 vcruntime140_cor3.dll	11/10/2022 8:04 AM	Application extens...	89 KB
 wpfgfx_cor3.dll	11/19/2022 11:18 PM	Application extens...	1,763 KB



# GrowSphere™

## Legacy System Configuration Tool

V 3.6.0.2

### Chose System Type

Select RadioNet

Radionet

Singlenet



Select Read Database, Select AgileIOUser.AGI file from the PoleNet folder, click Open

Select Read Database

Select AgileIOUser.AGI file from the PoleNet folder

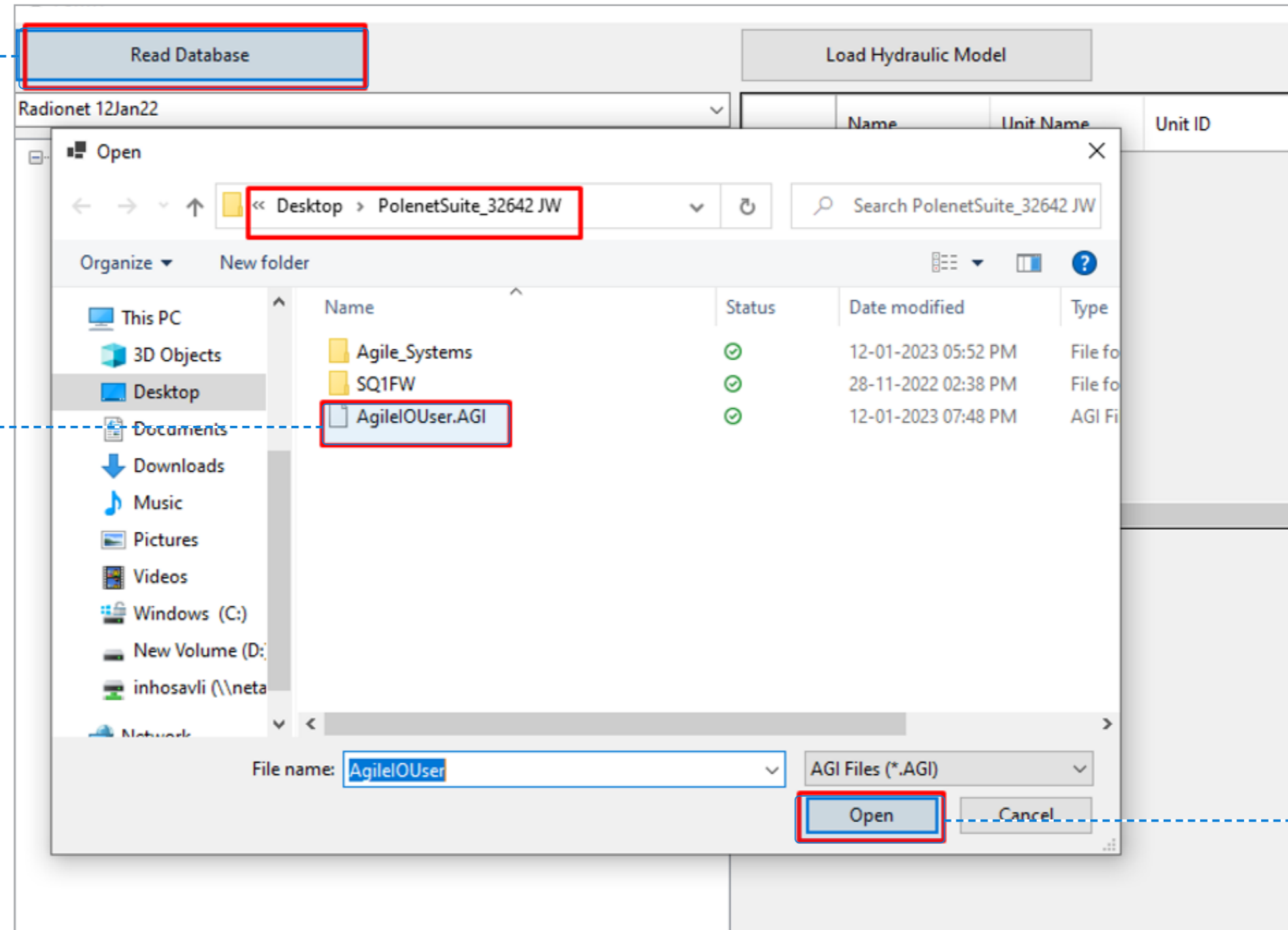

Click open



Chose correct file from list after Read Database.

The screenshot shows the 'Read Database' dropdown menu open, listing various test files and unit configurations. The main table below is empty, with columns for Name, Unit Name, IO Card, IO Address, Modbus Addresses, Mapped Device Type, Main Line, and Device Type ID. The 'Utilities' panel on the right includes buttons for 'Open Polenet', 'Auto Modbus Mapping', 'configuration', and 'Load Previous System'. A 'Save and Export' button is located at the bottom right of the interface.

Name	Unit Name	IO Card	IO Address	Modbus Addresses	Mapped Device Type	Main Line	Device Type ID
------	-----------	---------	------------	------------------	--------------------	-----------	----------------



PoleNet File and list of RTUs will be displayed

The screenshot shows the 'Form1' window in the GrowSphere MAX software. The interface includes several utility buttons at the top: 'Read Database', 'Load Hydraulic Model', 'Offline Work' (with a checkbox), 'Digital Outputs', 'Digital Inputs', and 'AI+Serial'. On the right side, there is a 'Utilities' panel with buttons for 'Open Polenet', 'Auto Modbus Mapping', 'configuration', 'Load Previous System', and 'Save and Export'.

The main area is divided into two panes. The left pane shows a tree view with 'Radio Test 13 Feb' selected. Under this folder, there is a 'Base (2021000000008610)' and a list of 'Unit' entries, each with a unique ID in parentheses. The right pane displays a table with the following columns: Name, Unit Name, IO Card, IO Address, Modbus Addresses, Mapped Device Type, Main Line, Device Type ID, Device Number, Nominal Area, and Nominal Flow Rate. The table is currently empty.



Click Auto Modbus Mapping and wait for message "Mapping Done", click Ok

The screenshot shows a software interface with several panels. On the left, a tree view shows a hierarchy starting with 'Radionet Net test 22 Nov' and containing numerous 'Unit' entries with IDs. The main central area is a table with columns: Name, Unit Name, Unit ID, Mapped Device Type, Main Line, Remote/Local, IO Card, IO Address, Modbus Address A, Modbus Address B, Modbus Address C, and Dev ID. Below this table is a 'Device Parameters' section with fields for IO Type (set to 'Digital Input'), RTU (set to 'Unit 09279'), and IO Number (set to '1'). On the right side, there is a 'Utilities' panel with buttons for 'Open Polenet', 'Auto Modbus Mapping', 'configuration', and 'Load Previous System'. A small dialog box titled 'Mapping done' with an 'OK' button is centered over the interface. A dashed blue line originates from the text above and points to the 'Auto Modbus Mapping' button.



Below screen shots shows “Before Mapping” and “After Mapping view on PoleNet Mapping View Tab.

Before Mapping

A...	Bit Out	Bit In	Word Out	Word In	Unit	Card	IO	IO Type	Parameter	Playback
1			40001		2021000000010528	1 (307)	1	DO	desired	
2			40001		2021000000010528	1 (307)	2	DO	desired	
3			40001		2021000000026299	1 (207)	3	DO	desired	
4			40001		2021000000026260	1 (207)	3	DO	desired	
5			40001		2021000000026300	1 (207)	3	DO	desired	
6			40001		2021000000026300	2 (208)	3	DO	desired	
7			40001		2021000000026300	2 (208)	4	DO	desired	
8			40001		2021000000026302	1 (207)	3	DO	desired	
9			40001		2021000000026302	2 (208)	3	DO	desired	
10			40001		2021000000026302	2 (208)	4	DO	desired	
11			40001		2021000000010489	1 (307)	1	DO	desired	
12			40001		2021000000010489	1 (307)	2	DO	desired	
13			40001		2021000000026259	1 (207)	3	DO	desired	
14			40001		2021000000026301	1 (207)	3	DO	desired	
15			40001		2021000000026301	2 (208)	3	DO	desired	
16			40001		2021000000026301	2 (208)	4	DO	desired	
17			40002		2021000000026308	1 (207)	3	DO	desired	
18			40002		2021000000026308	2 (208)	3	DO	desired	
19			40002		2021000000026308	2 (208)	4	DO	desired	
20			40002		2021000000026261	1 (207)	3	DO	desired	
		10001		30001	2021000000010528	1 (307)	1	DO	actual	
		10002		30001	2021000000010528	1 (307)	2	DO	actual	
		10003		30001	2021000000026299	1 (207)	3	DO	actual	
		10004		30001	2021000000026260	1 (207)	3	DO	actual	
		10005		30001	2021000000026300	1 (207)	3	DO	actual	
		10006		30001	2021000000026300	2 (208)	3	DO	actual	
		10007		30001	2021000000026300	2 (208)	4	DO	actual	
		10008		30001	2021000000026302	1 (207)	3	DO	actual	
		10009		30001	2021000000026302	2 (208)	3	DO	actual	
		10010		30001	2021000000026302	2 (208)	4	DO	actual	
		10011		30001	2021000000010489	1 (307)	1	DO	actual	

After Mapping



Connect to GS (in pic it is via RUT240 xx Modem)

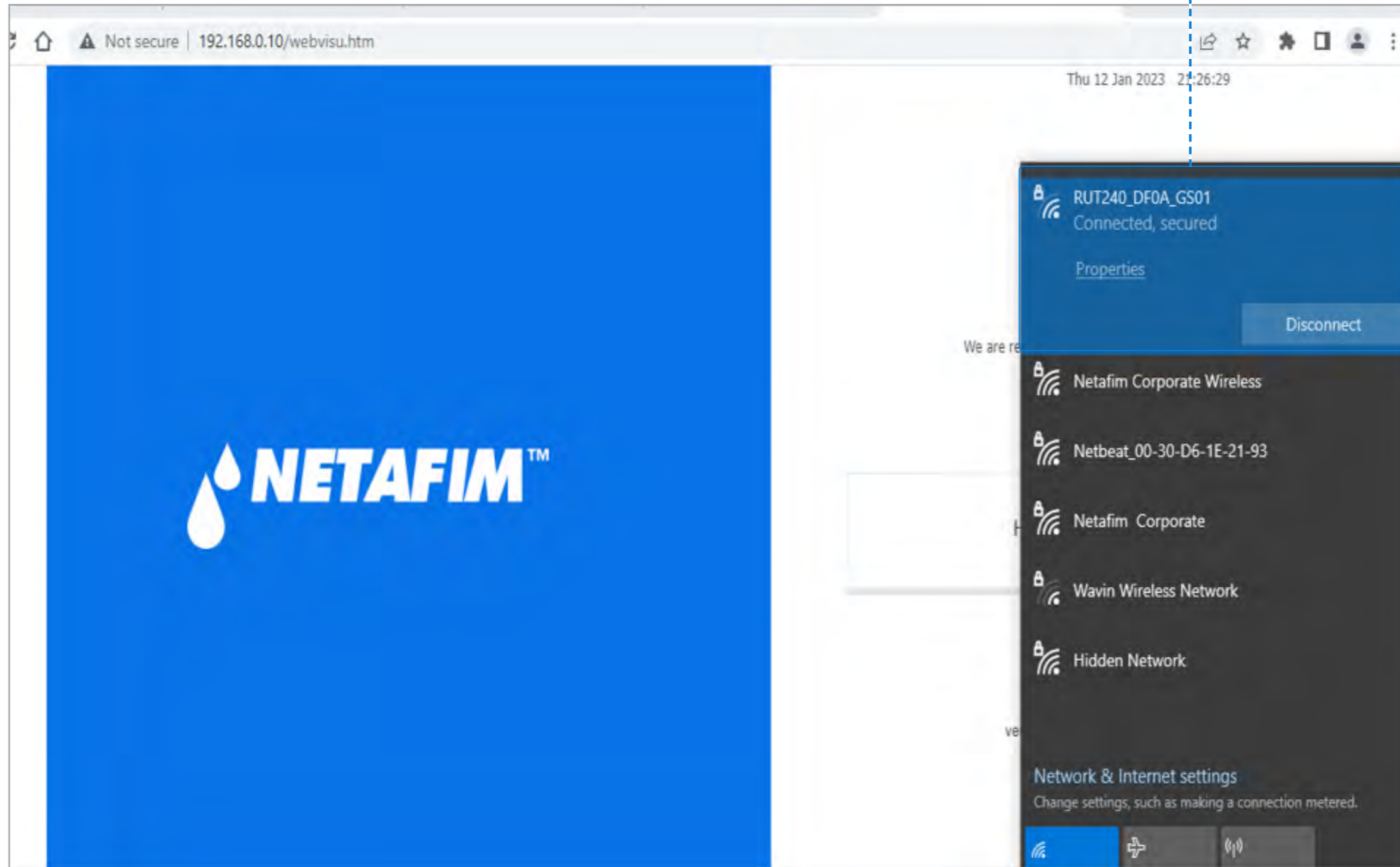

Wait for Message "File loaded successfully", Click OK

Click on "Load Hydraulic Model", Select Path sdcard >> RemoteSys >> Hydraulic Model.csv & Click on Open

The screenshot displays the 'Load Hydraulic Model' dialog box in a software application. The dialog is open to the path '192.168.0.10 > sdcard > RemoteSys' and shows a file named 'Hydraulic Model.csv' selected. The 'Open' button is highlighted with a red box. Below the dialog, the 'Device Parameters' section is visible, showing 'Digital Output' settings for 'Unit 000', 'IO Number 1', 'Mainline Main Line 1', 'Device Name Pump 1', and 'Flow 4'. A list of devices is shown on the right, with 'Pump 1' selected. The background shows a tree view of units and a table of IO addresses.

IO Address	Modbus Address A	Modbus Address B	Modbus Address C	II
1	1	257	0	0
2	2	258	0	0
1	3	259	0	0
2	4	260	0	0
1	5	261	0	0
2	6	262	0	0
1	7	263	0	0
2	8	264	0	0
1	9	265	0	0
2	10	266	0	0
1	11	267	0	0
2	12	268	0	0
1	13	269	0	0
2	14	270	0	0
1	15	271	0	0
2	16	272	0	0
1	17	273	0	0



Digital Outputs / Inputs / AI+Serial can be assigned by selecting relevant Tabs

The screenshot displays the GrowSphere MAX software interface. At the top, there are three tabs: "Digital Outputs", "Digital Inputs", and "AI+Serial". These tabs are highlighted with red boxes. A dashed blue line points from the text above to the "Digital Inputs" tab. The main area of the interface is a table with columns: Name, Unit Name, Unit ID, Mapped Device Type, Main Line, Remote/Local, IO Card, IO Address, Modbus Address A, Modbus Address B, Modbus Address C, and Dev ID. The table is currently empty. On the left side, there is a tree view showing a hierarchy of units under "Radionet Net test 22 Nov". On the right side, there is a "Utilities" panel with buttons for "Open Polenet", "Auto Modbus Mapping", "configuration", and "Load Previous System". At the bottom right, there is a "Save and Export" button.



Click on "Digital Outputs" Tab, this will show DOs available on all RTUs

The screenshot shows a software window titled 'Form1' with several tabs: 'Read Database', 'Load Hydraulic Model', 'Digital Outputs' (highlighted with a red box), 'Digital Inputs', and 'AI+Serial'. The 'Digital Outputs' tab is active, displaying a table with the following data:

Name	Unit Name	IO Card	IO Address	Modbus Addresses	Mapped Device Type	Main Line	Device Typ ID
	Unit 09279	1	3	6   10006   0		0	0
	Unit 09279	2	3	7   10007   0		0	0
	Unit 09279	2	4	8   10008   0		0	0
	Unit 09279	3	3	9   10009   0		0	0
	Unit 09279	3	4	10   10010   0		0	0
	Unit 09292	1	3	1   10001   0		0	0
	Unit 09292	2	3	2   10002   0		0	0
	Unit 09292	2	4	3   10003   0		0	0
	Unit 09292	3	3	4   10004   0		0	0
	Unit 09292	3	4	5   10005   0		0	0

On the left, a tree view shows the project structure under 'Radionet Net test 22 Nov-Copy', including a 'Base' and multiple 'Unit' entries with their respective IDs. On the right, a 'Utilities' panel contains buttons for 'Open Polenet', 'Auto Modbus Mapping', 'configuration', 'Load Previous System', and 'Save and Export'.



**2. Select Device to Allocate IO . Enter Details Device Name , Flow and Area Click Attach**

**1. Click on any DO. This will open the window below, enter details such as Mainline, Device Name, flow, Area & Flow indicator**

**Device Name & Details**

**Flow Indicator : Select Unit and Input to which it is connected**

The screenshot shows the software interface for configuring remote units. On the left is a tree view of the system hierarchy. The center features a table with columns: Name, Unit Name, IO Card, IO Address, Modbus Addresses, Mapped Device Type, Main Line, and Device Typ. A red box highlights the first row of the table. Below the table is a configuration window with fields for IO Type (Digital Output), RTU (Unit 09279), IO Number (3), Device Name (Banana 1), Flow (10), Area (1), Flow indicator (Unit 09279), and Unit (Unit 09279). A dropdown menu for 'Select Device to Allocate to this IO' shows a list of valves. A red box highlights the 'Attach' button at the bottom right of the configuration window.

Name	Unit Name	IO Card	IO Address	Modbus Addresses	Mapped Device Type	Main Line	Device Typ
1	Unit 09279	1	3	6   10006   0		0	0
	Unit 09279	2	3	7   10007   0		0	0
	Unit 09279	2	4	8   10008   0		0	0
	Unit 09279	3	3	9   10009   0		0	0
	Unit 09279	3	4	10   10010   0		0	0
	Unit 09292	1	3	1   10001   0		0	0
	Unit 09292	2	3	2   10002   0		0	0
	Unit 09292	2	4	3   10003   0		0	0
	Unit 09292	3	3	4   10004   0		0	0
	Unit 09292	3	4	5   10005   0		0	0



A Prompt message will appear, click Yes

Unit 09279	2	4	8   10008   0
Unit 09279	3	3	9   10009   0
Unit 09279	3	4	10   10010   0
Unit 09292	1	3	1   10001   0
Unit 09292	2	3	2   10002   0
Unit 09292	2	4	3   10003   0
Unit 09292	3	3	4   10004   0
Unit 09292			5   10005   0

Attach

Attach Valve 1 To DigitalOutput?

Yes No

Unit 09279

3

Main Line 1

Banana 1

10

1

Valve 3

Valve 4

Valve 5

Valve 6

Valve 7

Valve 8

Valve 9

Valve 10

Valve 11

Valve 12

Valve 13

Device will be mapped to Output on RTU & will be displayed in table

Load Hydraulic Model		Digital Outputs		Digital Inputs		AI+Serial	
Name	Unit Name	IO Card	IO Address	Modbus Addresses	Mapped Device Type	Main Line	Device Typ ID
Banana 1	Unit 09279	1	3	6   10053   0	Valve 1	1	1
	Unit 09279	2	3	7   10007   0		0	0



Click Digital Inputs Tab and Proceed to add Digital Input, select Mainline, Enter Device name etc, and click Attach Device Name (WM 1 here and associated with DI)

The screenshot shows the 'Digital Inputs' configuration window. On the left, a tree view shows the system hierarchy. The main window contains a table of digital inputs:

Name	Unit Name	IO Card	IO Address	Modbus Addresses	Mapped Device Type	Main Line	Device Type ID
Flow indicator 1	Unit 09279	1	1	10053   30644   ...	Flow indicator 1	1	31
	Unit 09279	1	2	10054   30645   ...		0	0
	Unit 09279	2	1	10055   30646   ...		0	0
	Unit 09279	2	2	10056   30650   ...		0	0
	Unit 09279	3	1	10057   30652   ...		0	0
	Unit 09279	3	2	10058   30654   ...		0	0
	Unit 09292	1	1	10047   30632   ...		0	0
	Unit 09292	1	2	10048   30634   ...		0	0
	Unit 09292	2	1	10049   30636   ...		0	0
	Unit 09292			10050   30638   ...		0	0

Below the table, the 'Device Parameters' section is visible:

- IO Type: Digital Input
- RTU: Unit 09279
- IO Number: 2
- Mainline: Main Line 1 (dropdown menu)
- Device Name: WM 1
- Pulse Rate: 10

An 'Attach' dialog box is open with the question: 'Attach Water meter 1 To DigitalInput?'. It has 'Yes' and 'No' buttons. The 'Attach' button in the main window is also highlighted.



## Netacap (DFM) support via RatioNet RTU connection

### Setup Netacap on GS MAX

#### Polenet2max

- Select AI+serial
- Select mainline then sensor.
- Press on the Attach button.
- Press on Save and Export to PLC

**Form1**

Read Database | Load Hydraulic Model |  Offline Work | Digital Outputs | Digital Inputs | **AI-Serial** | Utilities

RadioNet 10

Name	Unit Name	IO Card	IO Address	Modbus Addresses	Mapped Device Type	Main Line
Netal	Unit DCP	1	4	30708   0   0	General 0-20m...	1
netacp	Unit DCP	3	1	30709   30723   0	Netacp80 1	1

3. Should appear here

Device Parameters

IO Type: **Serial Input**

RTU: Unit DCP

IO Number: 1

Mainline: Main Line 1

Device Name: netacp

Select Device to Allocate to this IO

- Netacp80 1
- Netacp120 1
- Netacp60 1
- Netacp40 1
- Netacp30 1
- Netacp20 1
- Netacp80 2
- Netacp120 2
- Netacp60 2
- Netacp40 2
- Netacp30 2
- Netacp20 2

1. Select your sensor

2. Attach

Export to PLC

Attach | Detach | Save and Export



After all I/Os devices are assigned,  
Click "Save and Export".

The screenshot shows the 'Form1' window with several tabs: 'Read Database', 'Load Hydraulic Model', 'Digital Outputs', 'Digital Inputs', and 'AI+ Serial'. The 'Digital Inputs' tab is active, displaying a table of assigned devices. Below the table, the 'Device Parameters' section is visible, showing details for a 'Digital Input' device named 'WM 1' on 'Main Line 1'. A dialog box titled 'Saved To CSV' with an 'OK' button is overlaid on the interface. In the bottom right corner, the 'Save and Export' button is highlighted with a red box.

Name	Unit Name	IO Card	IO Address	Modbus Addresses	Mapped Device Type	Main Line	Device Typ ID
Flow indicator 1	Unit 09279	1	1	10053   30644   ...	Flow indicator 1	1	31
WM 1	Unit 09279	1	2	10054   30646   ...	Water meter 1	1	18
	Unit 09279	2	1	10055   30648   ...		0	0
	Unit 09279	2	2	10056   30650   ...		0	0
	Unit 09279	3	1	10057   30652   ...		0	0
	Unit 09279	3	2	10058   30654   ...		0	0
	Unit 09292	1	1	10047   30632   ...		0	0
	Unit 09292	1	2	10048   30634   ...		0	0
	Unit 09292			10049   30636   ...		0	0
	Unit 09292			10050   30638   ...		0	0

A message will appear  
"Saved to CSV". Click OK



After saving CSV, Go to the PoleNet Application and disconnect the system.  
Click on “Edit System in PoleNet” and select the last activated system &  
Activate again and connect PoleNet.

The image shows two side-by-side screenshots of the PoleNet software interface. The left screenshot shows the 'PoleNet (Agile Host v3 - connected)' window. It has three main sections: 'PC Connection' with a 'Disconnect' button highlighted in red; 'Activated System in PoleNet' showing 'System: Radonet Net test 22 Nov' and 'Version: 20230313\_170819' with an 'Edit Systems in PoleNet' button highlighted in red; and 'Agile Host v3' with various monitoring and configuration buttons. The right screenshot shows a database window titled 'Database: D:\PW Data\GrowSphere\PoleNetSuite\_32642 (W)\Agile\OUser.AGI'. It contains a table with the following data:

System Type	System	RTUs	PoleNet Status	Database Status	Modify Status	Last Modified Time
Agile (MODBUS)	Pressure Sensor test 15 Feb	2				2023-02-15 21:30:45
Agile (MODBUS)	Radonet Net test 22 Nov	21	Active (20230313)	Last activated		2023-03-13 17:08:19
Agile (MODBUS)	Radonet U3	3				2023-02-23 17:53:26
Agile (MODBUS)	Sergio	5				2023-02-20 17:52:07

The row for 'Radonet Net test 22 Nov' is highlighted in red. At the bottom of the database window, there are buttons for 'Merge', 'Activate' (highlighted in red), 'Edit', and 'Exit'.



The system will ask to Re-load the modified system. Click “Yes”. The system will ask to Select “Program database version into Host” and Confirm

Database: D:\PW Data\GrowSphere\PolenetSuite\_32642 JW\Agile\OUser.AGI

System Type	System	RTUs	PoleNet Status	Database Status	Modify Status	Last Modified Time
Agile (MODBUS)	Pressure Sensor test 15 Feb	2				2023-02-15 21:30:45
Agile (MODBUS)	Radionet Net test 22 Nov	21	Active (20230313...	Last activated	Newer	2023-03-17 22:08:54
Agile (MODBUS)	RadioNet Q3	3				2023-02-23 17:53:26
Agile (MODBUS)	Sergio	5				2023-02-20 17:52:07

Exporting Re-load system

Re-load the modified Agile system:  
Radionet Net test 22 Nov

Yes No

Host Capture - Options

SITUATION

Database contains a newer version of the system in the Host.

POSSIBLE ACTIONS TO TAKE

Program database version into Host. (Restarts radio system)

Replace version in the Database with version from Host

Cancel Confirm

Merge Activate Edit Exit



After a CSV upload, you can view the details in the "Mapping View" section of the PoleNet system.

Agile Systems Radionet Net test 22 Nov, using MODBUS

System	Mapping Edit	Mapping View	Direct Mapping View	Route	AutoMap						
Modb...	Bit Out	Bit In	Word...	Word...	Unit	Card	IO	IO T...	Param...	Playb...	
1	1		40001		2021000000009292	1 [207]	3 [Pomo 3]	DO	desired		
2	2		40001		2021000000009292	2 [208]	3 [Apple 1]	DO	desired		
3	3		40001		2021000000009292	2 [208]	4 [Apple 2]	DO	desired		
4	4		40001		2021000000009292	3 [208]	3 [Apple 3]	DO	desired		
5	5		40001		2021000000009292	3 [208]	4 [Kiwi 1]	DO	desired		
6	6		40001		2021000000009279	1 [207]	3 [Banana 1]	DO	desired		
7	7		40001		2021000000009279	2 [208]	3 [Banana 2]	DO	desired		
8	8		40001		2021000000009279	2 [208]	4 [Banana 3]	DO	desired		
9	9		40001		2021000000009279	3 [208]	3 [Pomo 1]	DO	desired		
10	10		40001		2021000000009279	3 [208]	4 [Pomo 2]	DO	desired		
11	11		40001		2021000000009687	1 [307]	1 [Kiwi 2]	DO	desired		
12	12		40001		2021000000009687	1 [307]	2 [Kiwi 3]	DO	desired		
13	13		40001		2021000000010528	1 [307]	1 [Vegitable 3]	DO	desired		
14	14		40001		2021000000010528	1 [307]	2 [Vegitable 4]	DO	desired		
15	15		40001		2021000000026309	1 [207]	3	DO	desired		
16	16		40001		2021000000010489	1 [307]	1 [Vegitable 1]	DO	desired		
17	17		40002		2021000000010489	1 [307]	2 [Vegitable 2]	DO	desired		
18	18		40002		2021000000026299	1 [207]	3 [DC 1]	DO	desired		
19	19		40002		2021000000026300	1 [207]	3 [DC 2]	DO	desired		
20	20		40002		2021000000026300	2 [208]	3 [DC 3]	DO	desired		
21	21		40002		2021000000026300	2 [208]	4 [DC 4]	DO	desired		
22	22		40002		2021000000026260	1 [207]	3 [Vegi 6]	DO	desired		
23	23		40002		2021000000026302	1 [207]	3	DO	desired		
24	24		40002		2021000000026302	2 [208]	3	DO	desired		
25	25		40002		2021000000026302	2 [208]	4	DO	desired		
26	26		40002		2021000000026259	1 [207]	3 [Vegitable 5]	DO	desired		
27	27		40002		2021000000026301	1 [207]	3 [DB Fk]	DO	desired		
28	28		40002		2021000000026301	2 [208]	3 [MV Fruit & Vegi]	DO	desired		
29	29		40002		2021000000026301	2 [208]	4 [Fruit and Vegi]	DO	desired		
30	30		40002		2021000000026308	1 [207]	3	DO	desired		
31	31		40002		2021000000026308	2 [208]	3	DO	desired		
32	32		40002		2021000000026308	2 [208]	4	DO	desired		
33	33		40003		2021000000026261	1 [207]	3 [Vegi 7]	DO	desired		
34	34		40003		2021000000026307	1 [207]	3	DO	desired		
35	35		40003		2021000000026307	2 [208]	3	DO	desired		
36	36		40003		2021000000026307	2 [208]	4	DO	desired		
37	37		40003		2021000000026262	1 [207]	3 [Vegi 8]	DO	desired		
38	38		40003		2021000000026306	1 [207]	3	DO	desired		
39	39		40003		2021000000026306	2 [208]	3	DO	desired		
40	40		40003		2021000000026306	2 [208]	4	DO	desired		
41	41		40003		2021000000026304	1 [207]	3	DO	desired		
42	42		40003		2021000000026303	1 [207]	3	DO	desired		
43	43		40003		2021000000026305	1 [207]	3	DO	desired		



Go to GrowSphere Screen , Under “Communication” select “RadioNet Allocation” and click on “Start Allocation”

RTU S.N.	#ID	Status	Name	FW ver.
2190000000000000	0	Connected	AgileHostUnit	3.29
2021000000028253	0	Connected	Base	2.75
2021000000017420	101	Connected	Unit17420	2.69
2021000000020934	168	Connected	Unit20934	2.75

Confirm all CSV files are detected. Click on “ Overwrite existing devices if already system have definition for SingleNet or NetRTU

Files Detect :

- DI CSV file
- DO CSV file
- AI CSV file
- Info CSV file

Add to existing devices
  Overwrite existing devices



Check all I/O s are appeared.

The image shows two screenshots of the GrowSphere MAX web interface. The top screenshot displays the 'Remote I/O' configuration page with the 'Remote serial sensors' tab selected. The bottom screenshot displays the 'Remote I/O' configuration page with the 'Remote digital input' tab selected.

**Top Screenshot: Remote I/O - Remote serial sensors**

RTU	Card	IO	Device type	NO.	Source	Name	Flow	Area (ha)	Assigned
26300	1	3	Valve	3	M.Line3	Valve3	10.0 m³/h	0.00	Unassign
26300	2	3	Valve	4	M.Line3	Valve4	10.0 m³/h	0.00	Unassign
26300	2	4	Valve	5	M.Line3	Valve5	10.0 m³/h	0.00	Unassign
10489	1	1	Valve	1	M.Line3	Valve1	10.0 m³/h	0.00	Unassign
10489	1	2	Valve	2	M.Line3	Valve2	10.0 m³/h	0.00	Unassign
26302	1	3	Pump	1	M.Line3	Pump1	10.0 m³/h	—	Unassign

**Bottom Screenshot: Remote I/O - Remote digital input**

RTU	Card	IO	Device type	NO.	Source	Name	Type	Rate	Assigned
	1	1	Water metri	1	M.Line1	Banana1	LPP	10.00	Unassign



→ To test Valve operations from UI.

Click on any Valve and  
Click on "Manual On"

The screenshot shows the GrowSphere MAX interface with the following elements:

- Navigation Bar:** Farm, All Mainlines, Settings, and a date/time display (Wed 05 Jun 2024 06:57:20).
- Configuration Tabs:** Configuration, Local I/O, Remote I/O (selected), Communication, Wiring Diagram.
- Sub-Tabs:** Remote digital output, Remote digital input, Remote analog input, Remote serial sensors (selected), Unallocated devices.
- Table:**

RTU	Card	IO	Device type	Container device type	NO.	Source	Name	Assigned
	3	1	NetaCap water co	NetaCap 80 cm	1	ML 1	NC1WC1	Unassign
	3	1	NetaCap water co	NetaCap 80 cm	2	ML 1	NC1WC2	Unassign
	3	1	NetaCap water co	NetaCap 80 cm	3	ML 1	NC1WC3	Unassign
27768	3	1	NetaCap water co	NetaCap 80 cm	4	ML 1	NC1WC4	Unassign
27768	3	1	NetaCap water co	NetaCap 80 cm	5	ML 1	NC1WC5	Unassign
27768	3	1	NetaCap water co	NetaCap 80 cm	6	ML 1	NC1WC6	Unassign
27768	3	1	NetaCap soil temp	NetaCap 80 cm	1	ML 1	NC1ST1	Unassign
- Callout Box:** A red-bordered box highlights the 'Manual - On' button for 'Valve1'. Other buttons shown are 'Auto' and 'Valve1'.



## 12.3 SingleNet to GrowSphere™ MAX

SingleNet interface with GS is only via RS485. RS485 Module must be installed on Upper Port. Note the “DIP Switch” position on the RS 485 Module marked in RED must be towards the “ON” Side

Wiring Between Host & GS max Controller A to A & B To B. also LK1 & LK2 Jumper on the SingleNet Host should be Upper side

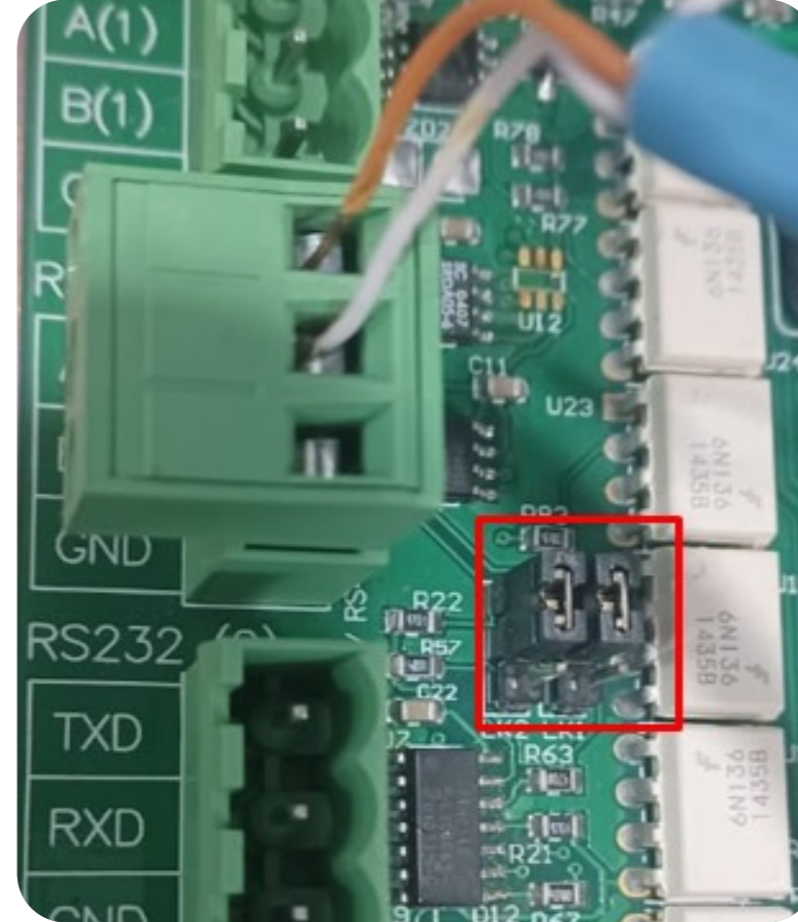
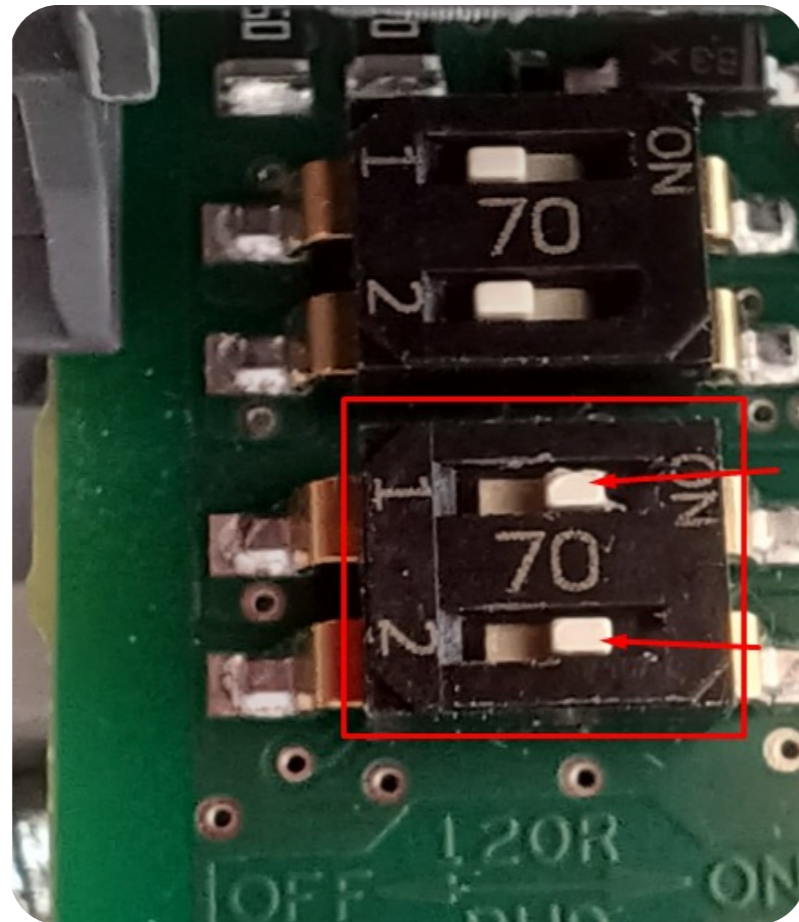

SingleNet Host

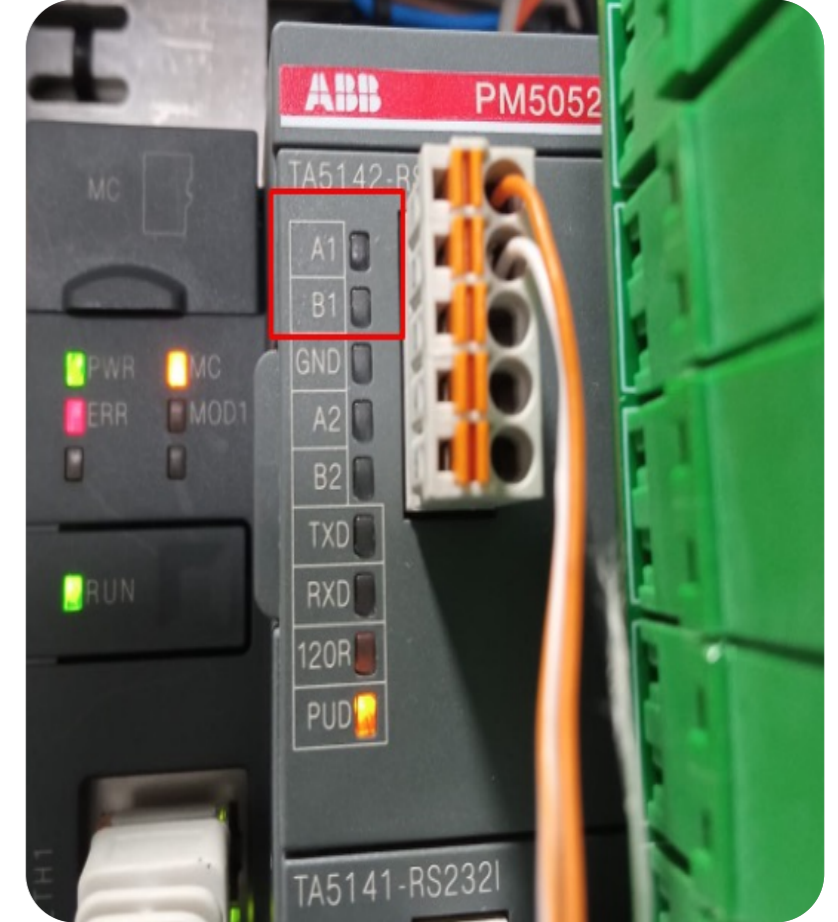

GrowSphere™ Max Controller



## / Required Polenet Version

Always Check for Latest & Recommended Versions of PoleNet & Polenet2Max App.

- **Use Polenet Version:** 3.26.42 Or Newer Version

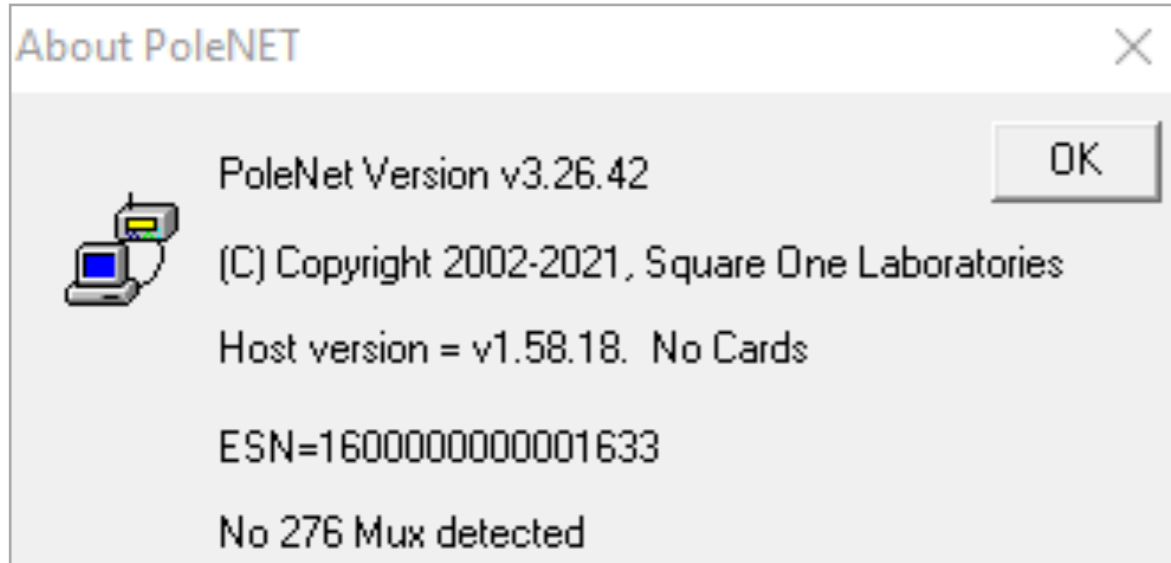
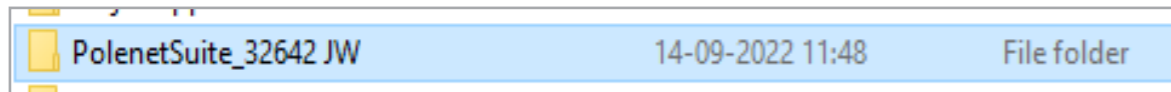

- **Use Host Firmware Version:** 1.58.18 Or Newer
- **Use RTU Firmware Version :** 1.66 Or Newer

## / Navigate to Settings >> Communication >> Select SingleNet >> Export Hydraulic Model

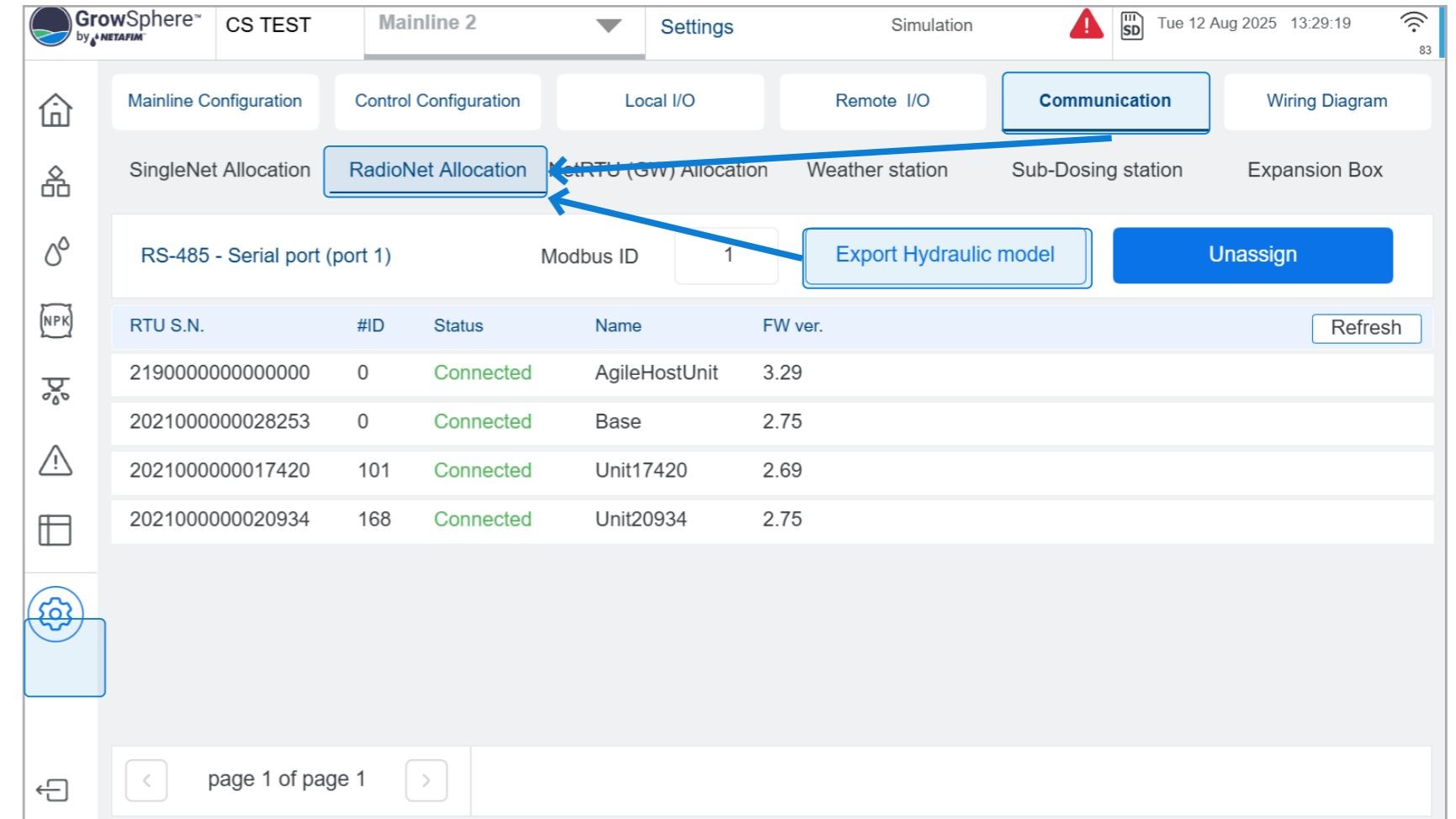

### / After Successful "Export", Click Done

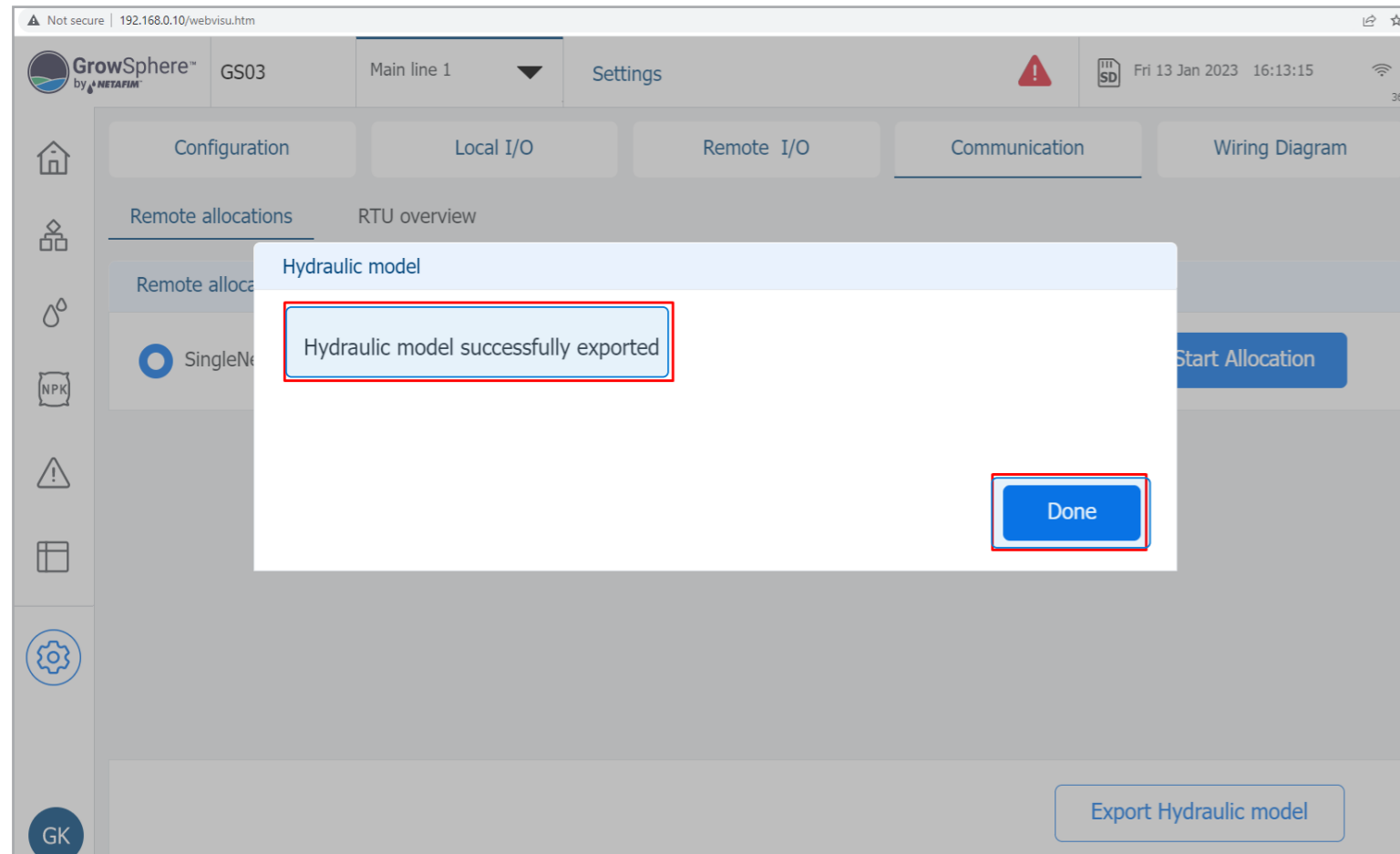

### / Select SingleNet

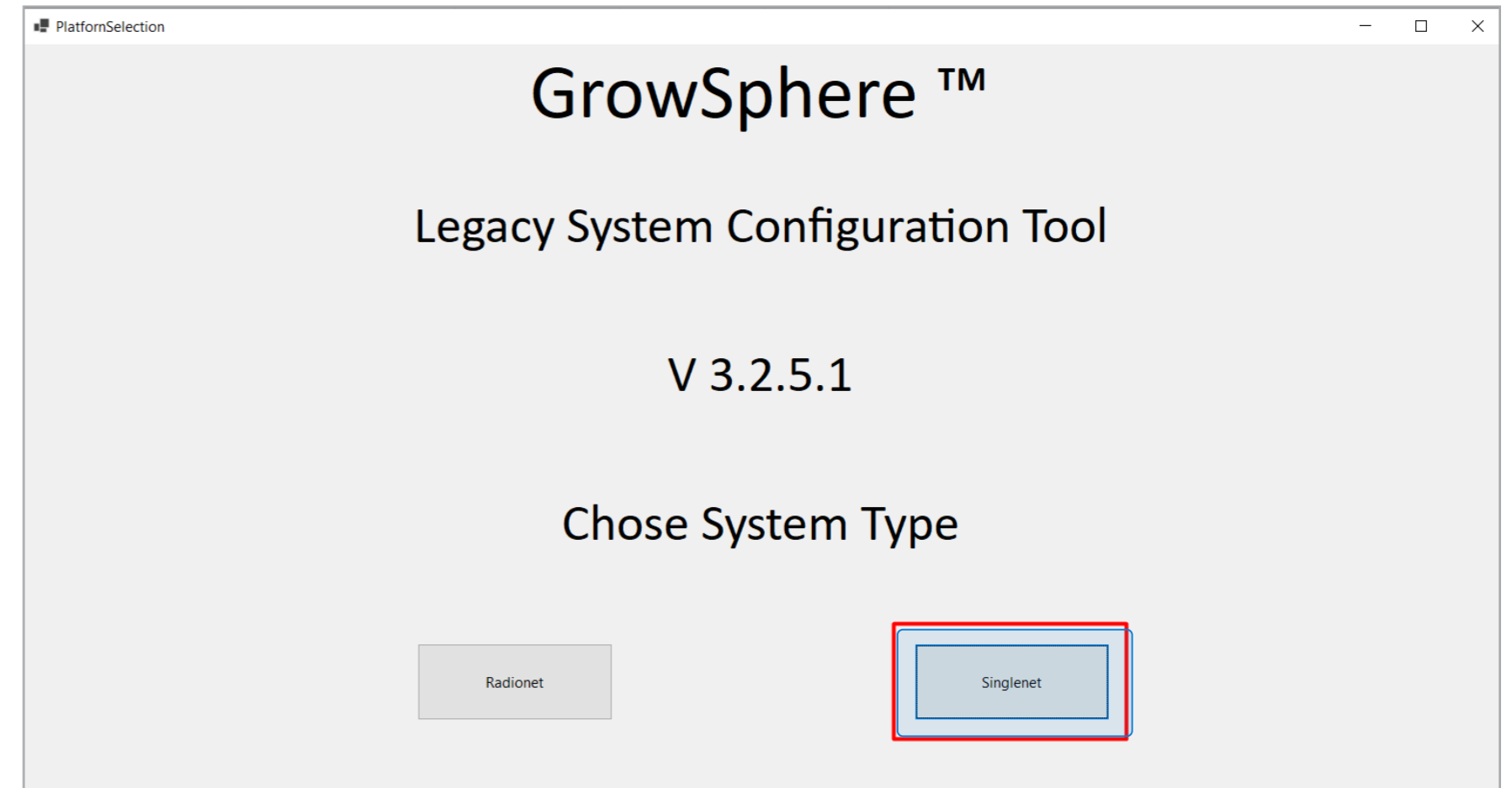

/ Open "Polenet2Max" Application

Name	Date modified	Type	Size
configuration.properties	11/15/2022 1:13 PM	PROPERTIES File	1 KB
D3DCompiler_47_cor3.dll	5/6/2022 8:46 PM	Application extens...	4,031 KB
devices_types	11/10/2022 7:00 PM	JSON File	23 KB
illust58-1841	11/28/2022 5:35 PM	JPG File	1,468 KB
Penlmc_cor3.dll	11/19/2022 11:16 PM	Application extens...	143 KB
<b>Polenet2Max</b>	<b>1/18/2023 2:32 PM</b>	<b>Application</b>	<b>155,001 KB</b>
Polenet2Max.pdb	1/18/2023 2:31 PM	PDB File	50 KB
PresentationNative_cor3.dll	10/13/2022 11:46 PM	Application extens...	924 KB
sni.dll	7/12/2017 4:54 PM	Application extens...	134 KB
SQLite.Interop.dll	11/2/2021 11:17 PM	Application extens...	1,343 KB
vcruntime140_cor3.dll	11/10/2022 8:04 AM	Application extens...	89 KB
wpfgfx_cor3.dll	11/19/2022 11:18 PM	Application extens...	1,763 KB

/ Total 128 Units 0 to 127, will be listed by default

The screenshot shows the 'Form1' window of the Polenet2Max application. On the left, a tree view shows 'SingleNet' expanded to reveal a list of units from 'Unit 000 (000)' to 'Unit 026 (026)'. The main area is a table with columns: Name, Unit Name, Unit ID, Mapped Device Type, Main Line, Remote/Local, IO Card, IO Address, Modbus Address A, and Modbus Address B. The table is currently empty. On the right, there are utility buttons: 'Open Polenet', 'Auto Modbus Mapping', 'configuration', 'Load Previous System', and 'Save and Export'.



/ Connect to MAX (in pic it is via RUT240 xx Modem)

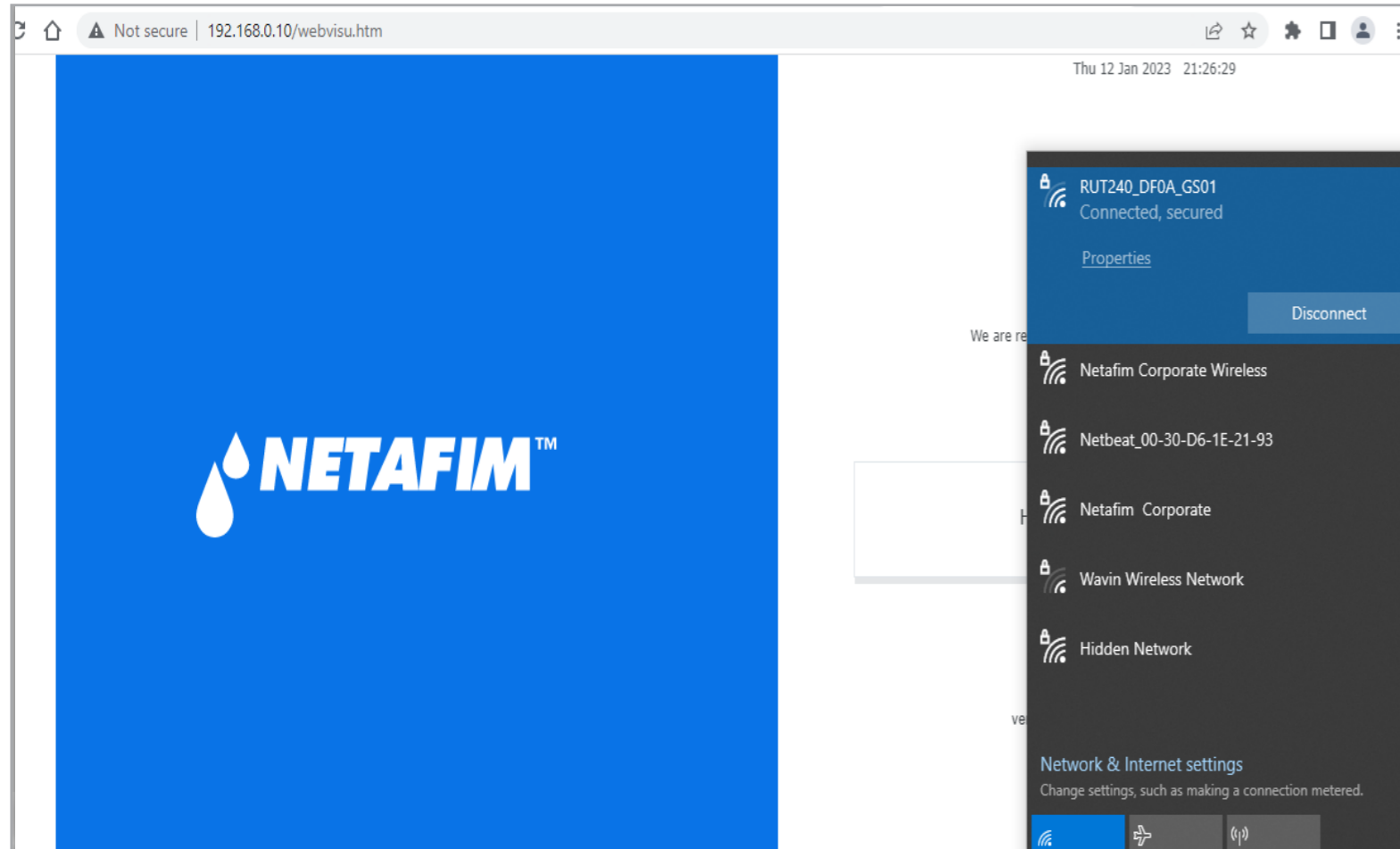

/ Wait for Message "File loaded successfully", Click OK

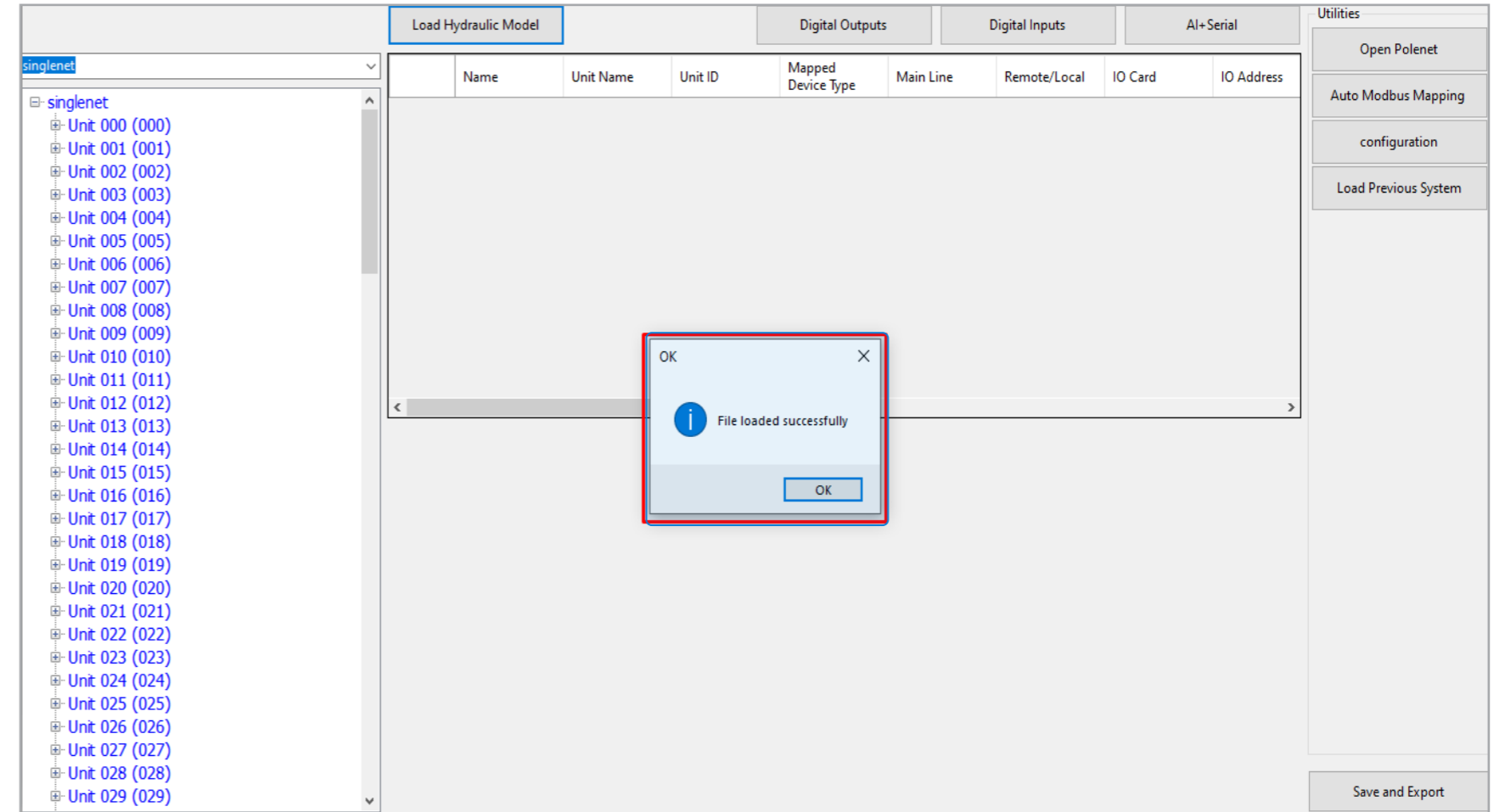

/ Click on “Load Hydraulic Model”, Select Path sdcard >> RemoteSys >> Hydraulic Model.csv & Click on Open

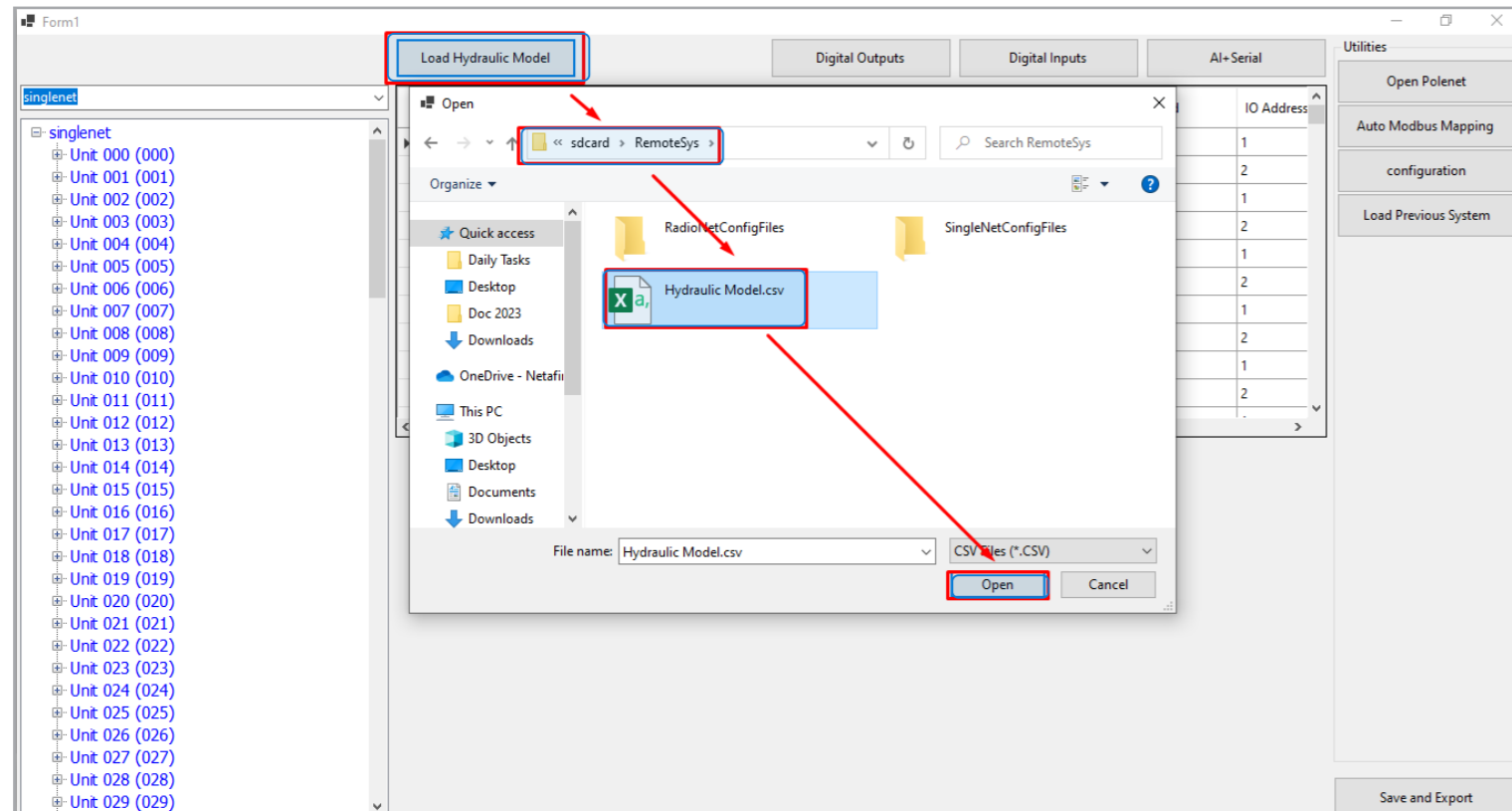

/ Digital Outputs / Inputs can be assigned by selecting relevant Tabs

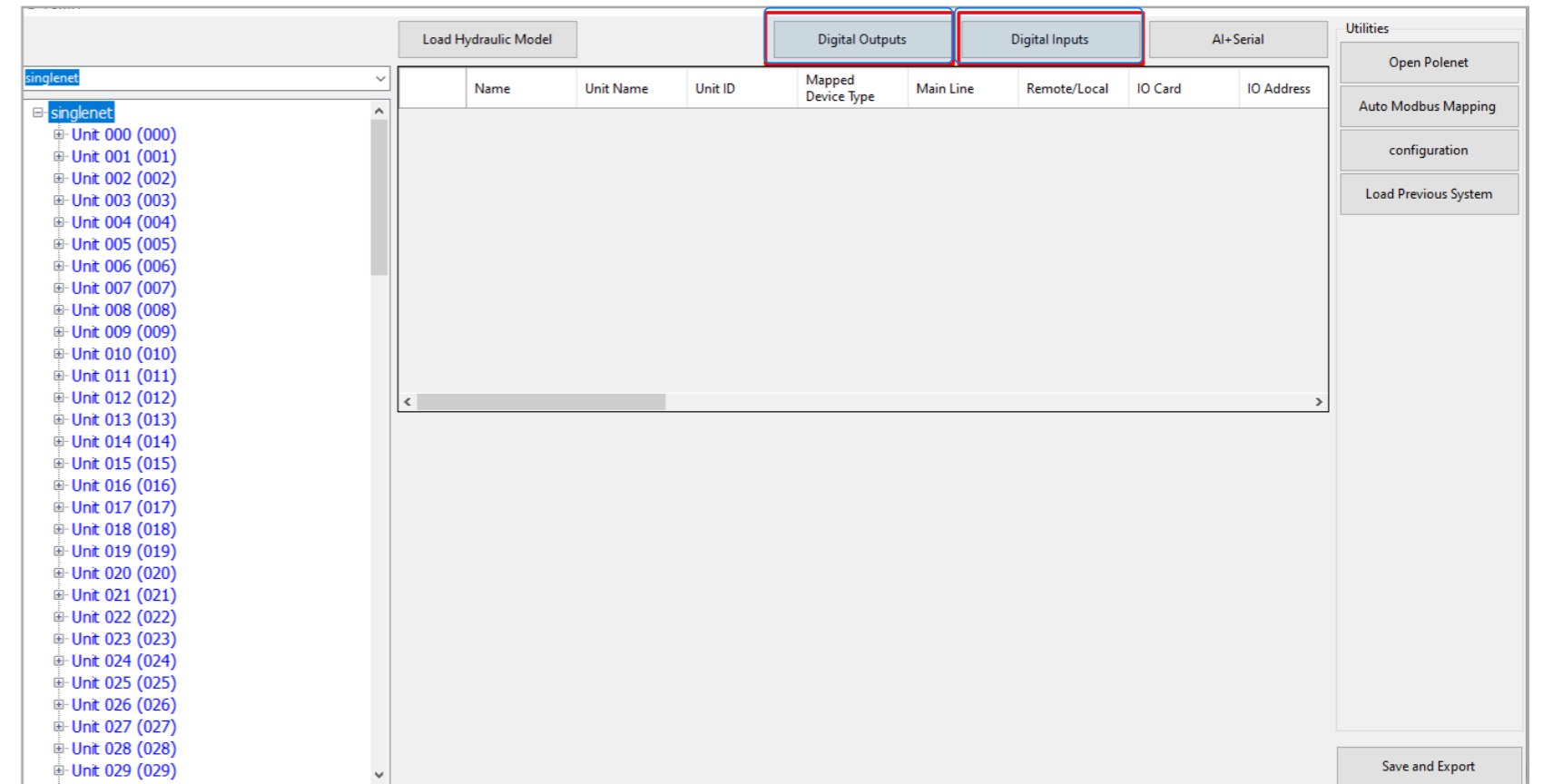

/ Click on “Digital Outputs” Tab, this will show DOs available on all RTUs

Name	Unit Name	Unit ID	Mapped Device Type	Main Line	Remote/Local	IO Card	IO Address	Modbus Address A	Modbus Address B	Modbus Address C	C	I
DO 0.1	Unit 000	000		0	4	1	1	1	257	0	0	0
DO 0.2	Unit 000	000		0	4	1	2	2	258	0	0	0
DO 1.1	Unit 001	001		0	4	1	1	3	259	0	0	0
DO 1.2	Unit 001	001		0	4	1	2	4	260	0	0	0
DO 2.1	Unit 002	002		0	4	1	1	5	261	0	0	0
DO 2.2	Unit 002	002		0	4	1	2	6	262	0	0	0
DO 3.1	Unit 003	003		0	4	1	1	7	263	0	0	0
DO 3.2	Unit 003	003		0	4	1	2	8	264	0	0	0
DO 4.1	Unit 004	004		0	4	1	1	9	265	0	0	0
DO 4.2	Unit 004	004		0	4	1	2	10	266	0	0	0
DO 5.1	Unit 005	005		0	4	1	1	11	267	0	0	0
DO 5.2	Unit 005	005		0	4	1	2	12	268	0	0	0
DO 6.1	Unit 006	006		0	4	1	1	13	269	0	0	0
DO 6.2	Unit 006	006		0	4	1	2	14	270	0	0	0
DO 7.1	Unit 007	007		0	4	1	1	15	271	0	0	0
DO 7.2	Unit 007	007		0	4	1	2	16	272	0	0	0
DO 8.1	Unit 008	008		0	4	1	1	17	273	0	0	0

/ Select Device to Allocate IO. Enter Details Device Name , Flow and Area Click Attach

**Flow Indicator:**      **Device Name & Details**

Select Unit and Input to which it is connected



/ Click on any DO. This will open the window below, enter details such as Mainline, Device Name, flow, Area & Flow indicator

The screenshot shows the 'Digital Outputs' configuration window. A table lists various DOs with columns for Name, Unit Name, Unit ID, Mapped Device Type, Main Line, Remote/Local, IO Card, IO Address, Modbus Address A, Modbus Address B, and Modbus Address C. An arrow points to the 'DO 1.1' row. Below the table, the 'Device Parameters' section is visible, showing fields for IO Type, RTU, IO Number, Mainline (set to 'Main Line 1'), Device Name (set to 'SugarCane V1'), Flow (set to '4'), Area (set to '1'), Flow indicator, Unit, Card, and Input. A 'Select Device to Allocate to this IO' list on the right contains 'Valve 1' through 'Valve 29'. The 'Attach' button is highlighted.

/ A Prompt message will appear, click Yes

The screenshot shows the same configuration window as the previous one, but with a dialog box titled 'Attach' overlaid. The dialog box contains the text 'Attach Valve 1 To Digital Output?' and two buttons: 'Yes' and 'No'. The 'Yes' button is highlighted with a red box. The background configuration window is dimmed.



/ In Digital Inputs Details of flow Indicator assigned to DO can be seen here

Name	Unit Name	Unit ID	Mapped Device Type	Main Line	Remote/Local	IO Card	IO Address	Modbus Address A	Modbus Address B	Modbus Address C
DI 0.1	Unit 000	000		0	4	1	1	49	49	305
DI 0.2	Unit 000	000		0	4	1	2	50	50	306
Flow indicator 1	Unit 001	001	Flow indicator 1	1	4	1	1	51	51	307
Flow indicator 3	Unit 001	001	Flow indicator 3	1	4	1	2	52	52	308
DI 2.1	Unit 002	002		0	4	1	1	53	53	309
DI 2.2	Unit 002	002		0	4	1	2	54	54	310
DI 3.1	Unit 003	003		0	4	1	1	55	55	311
DI 3.2	Unit 003	003		0	4	1	2	56	56	312
DI 4.1	Unit 004	004		0	4	1	1	57	57	313
DI 4.2	Unit 004	004		0	4	1	2	58	58	314
DI 5.1	Unit 005	005		0	4	1	1	59	59	315
DI 5.2	Unit 005	005		0	4	1	2	60	60	316
DI 6.1	Unit 006	006		0	4	1	1	61	61	317
DI 6.2	Unit 006	006		0	4	1	2	62	62	318

/ If there are Digital Input on RTU, Click on relevant Tab to assign it.

Name	Unit Name	Unit ID	Mapped Device Type	Main Line	Remote/Local	IO Card	IO Address	Modbus Address A	Modbus Address B	Modbus Address C
DI 0.1	Unit 000	000		0	4	1	1	49	49	305
DI 0.2	Unit 000	000		0	4	1	2	50	50	306
Flow indicator 1	Unit 001	001	Flow indicator 1	1	4	1	1	51	51	307
Flow indicator 3	Unit 001	001	Flow indicator 3	1	4	1	2	52	52	308
DI 2.1	Unit 002	002		0	4	1	1	53	53	309
DI 2.2	Unit 002	002		0	4	1	2	54	54	310
DI 3.1	Unit 003	003		0	4	1	1	55	55	311
DI 3.2	Unit 003	003		0	4	1	2	56	56	312
DI 4.1	Unit 004	004		0	4	1	1	57	57	313
DI 4.2	Unit 004	004		0	4	1	2	58	58	314
DI 5.1	Unit 005	005		0	4	1	1	59	59	315
DI 5.2	Unit 005	005		0	4	1	2	60	60	316
DI 6.1	Unit 006	006		0	4	1	1	61	61	317
DI 6.2	Unit 006	006		0	4	1	2	62	62	318

Device Parameters

IO Type: **Digital Input**

RTU: Unit 000

IO Number: 1

Mainline:

Device Name:

Pulse Rate:

**Note:**

Flow Indicator Input is not to be defined in Growsphere Hydraulic Configuration anywhere. It is only to "confirm" the Valve is OPEN & there is flow. On Growsphere >> Remote Valves, it will show "P". This facility is only for Valves on RTU



/ Click Digital Inputs Tab and Proceed to add Digital Input, select Mainline, Enter Device name etc, and click Attach Device Name (HU WM 1 here and associated with DI)

/ After all I/Os devices are assigned, Click "Save and Export ". A message will Appear "Saved to CSV". Click OK

Name	Unit Name	Unit ID	Mapped Device Type	Main Line	Remote/Local	IO Card	IO Address	Modbus Address A	Modbus Address B	Modbus Address C
DI 0.1	Unit 000	000		0	4	1	1	49	49	305
DI 0.2	Unit 000	000		0	4	1	2	50	50	306
Flow indicator 1	Unit 001	001	Flow indicator 1	1	4	1	1	51	51	307
Flow indicator 3	Unit 001	001	Flow indicator 3	1	4	1	2	52	52	308
DI 2.1	Unit 002	002		0	4	1	1	53	53	309
DI 2.2	Unit 002	002		0	4	1	2	54	54	310
DI 3.1	Unit 003	003		0	4	1	1	55	55	311
DI 3.2	Unit 003	003		0	4	1	2	56	56	312
DI 4.1	Unit 004	004		0	4	1	1	57	57	313
DI 4.2	Unit 004	004		0	4	1	2	58	58	314
DI 5.1	Unit 005	005		0	4	1	1	59	59	315
DI 5.2	Unit 005	005		0	4	1	2	60	60	316
DI 6.1	Unit 006	006		0	4	1	1	61	61	317
DI 6.2	Unit 006	006		0	4	1	2	62	62	318

Name	Unit Name	Unit ID	Mapped Device Type	Main Line	Remote/Local	IO Card	IO Address	Modbus Address A	Modbus Address B	Modbus Address C
Pump 1	Unit 000	000	Pump 1	0	4	1	1	1	257	0
MV 1	Unit 000	000		0	4	1	2	2	258	0
SugarCane V1	Unit 001	001	Valve 1	1	4	1	1	3	515	0
Banana V2	Unit 001	001	Valve 3	1	4	1	2	4	516	0
Pomo V2	Unit 002	002	Valve 2	1	4	1	1	5	261	0
Ginger V4	Unit 002	002	Valve 4	1	4	1	2	6	262	0
Custard V5	Unit 003	003	Valve 5	1	4	1	1	7	263	0
Banana V6	Unit 003	003	Valve 6	1	4	1	2	8	264	0
SugarCane V7	Unit 004	004	Valve 7	1	4	1	1	9	265	0
Pomo V 8	Unit 004	004	Valve 8	1	4	1	2	10	266	0
Custard V9	Unit 005	005		4	4	1	1	11	267	0
Ginger V10	Unit 005	005		4	4	1	2	12	268	0
Pomo V11	Unit 006	006		4	4	1	1	13	269	0
Veg V12	Unit 006	006		4	4	1	2	14	270	0



**/ Confirm all CSV files are detected. Click on "Overwrite existing devices"**

GrowSphere™ GS03 Main line 1 Settings

Configuration Local I/O Remote I/O Communication Wiring Diagram

Remote allocations RTU overview

Remote allocations

SingleNet Allocation  RadioNet Allocation  NetRTU (GW) Allocation Start Allocation

DI CSV file ✓  
DO CSV file ✓  
AI CSV file  
Info CSV file ✓

Add to existing devices Overwrite existing devices Cancel

Export Hydraulic model

**/ Check that all I/O appear**

GrowSphere™ GS03 Main line 1 Settings

Configuration Local I/O Remote I/O Communication Wiring Diagram

Remote digital output Remote digital input Remote analog input Unallocated devices

RTU	Card	IO	Device type	NO.	Source	Name	Flow	Area (ha)	Assigned
	1	1	Pump	1	M.Line0	Pump1	4.0 m³/h	—	Unassign
	1	1	Valve	1	M.Line1	SugarCan	4.0 m³/h	1.00	Unassign
	1	2	Valve	3	M.Line1	BananaV2	4.0 m³/h	1.00	Unassign
	1	1	Valve	2	M.Line1	PomoV2	4.0 m³/h	1.00	Unassign
	1	2	Valve	4	M.Line1	GingerV4	4.0 m³/h	0.00	Unassign
	1	1	Valve	5	M.Line1	CustardV	4.0 m³/h	1.00	Unassign
	1	2	Valve	6	M.Line1	BananaV6	4.0 m³/h	1.00	Unassign

GrowSphere™ GS03 Main line 1 Settings

Configuration Local I/O Remote I/O Communication Wiring Diagram

Remote digital output Remote digital input Remote analog input Unallocated devices

RTU	Card	IO	Device type	NO.	Source	Name	Type	Rate	Assigned
	1	1	Water metr	1	M.Line1	HUWM1	LPP	10.00	Unassign
	1	2	Dosing mel	1	M.Line1	DosingBa	LPP	1.00	Unassign



/ To test, Click on Valve, Select Manual-On >> "M"(Manual) & "P"(Pending) will appear. "P" will disappear and Valve will turn Green when Status Changes to ON in PoleNet

The screenshot shows the 'Valves' section of the GrowSphere MAX interface. A dropdown menu is open for the 'PomoV2' valve, with 'Manual - On' highlighted in a red box. The background shows the 'General' tab with 'PomoV2' also highlighted in a red box, displaying 'M P' next to it.

This block contains two screenshots. The left one shows the 'Valves' UI with 'PomoV2' in Manual mode, indicated by a yellow 'M' icon and green text, highlighted in a red box. The right one shows a 'Two-wire Monitor' window with a table of valve statuses. Row 2 is highlighted in red, showing 'On' status.

Unit	Out1	Out2	In1	In2	Capt	Avail	Drops
0			8	0	Yes	Yes	0
1			0	0	Yes	Yes	0
2			0	0	Yes	Yes	0
3			0	0	Yes	Yes	0
4			0	0	Yes	Yes	0
5			0	0	Yes	Yes	0
6			0	0	Yes	Yes	0
7			0	0	Yes	Yes	0
8			0	0	Yes	Yes	0
9			0	0	Yes	Yes	0
10			0	0	Yes	Yes	0
11			2	8	Yes	Yes	0
12			0	0	Yes	Yes	0
13			0	0	Yes	Yes	0

/ To close Valve from UI, click the Valve & Select Auto >> You can see the Valve Status disappears in PoleNet and Valve In UI turns Black

The screenshot shows the 'Valves' section of the GrowSphere MAX interface. A dropdown menu is open for the 'PomoV2' valve, with 'Auto' highlighted in a red box. The background shows 'PomoV2' with a yellow 'M' icon, also highlighted in a red box.

The screenshot shows the 'Valves' section of the GrowSphere MAX interface. 'PomoV2' is now in Manual mode, indicated by a yellow 'M' icon and black text, highlighted in a red box.

**Note:**  
If "Manual -OFF" is chosen, Valve will not open in AUTO mode. Need to Select " AUTO " to make it active. "M" against the Valve is the indication of Manual OFF





Precision  
Agriculture



# Thank you!

